

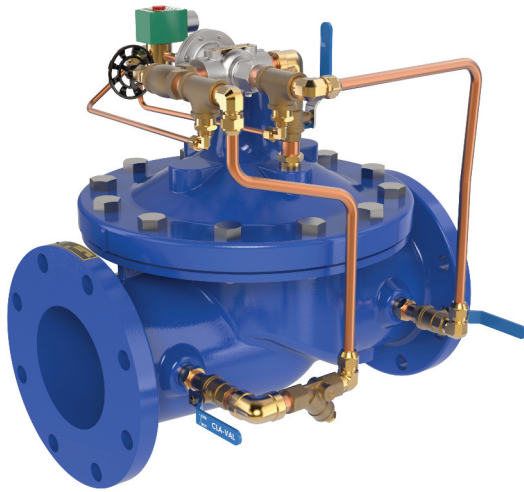

# MODEL 636-03

## Solenoid Control Valve



- Fast Acting Solenoid Control
- Drip Tight Shut-Off
- Simple Design, Proven Reliable
- Optional Check Feature
- Easy Installation & Maintenance

The Cla-Val Model 636-03 Solenoid Control Valve is an on-off control valve which either opens fully or closes drip-tight upon receiving an electrical signal to the solenoid pilot control. This valve consists of a Hytrol main valve, a three way solenoid and a high capacity three-way pilot valve. The solenoid control operates the three-way valve which alternately applies pressure to or relieves pressure from the diaphragm chamber of the main valve. It is furnished either normally open (de-energize solenoid to open) or normally closed (energize solenoid to open).

If the check feature option is added and a pressure reversal occurs, the downstream pressure is admitted into the main valve cover chamber and the valve closes to prevent return flow.

### Schematic Diagram

Item	Description
1	100-20 Hytrol Main Valve
2	CS3 Solenoid Control
3	102E Three-Way Valve
4	CNA Needle Valve (Closing)

### Optional Features

Item	Description
A	X46 Flow Clean Strainer
B	CK2 (Isolation Valve)
D	Check Valves With Isolation Valve
F	Independent Operating Pressure
H	Atmospheric Drain
P	X141 Pressure Gauge
S	CNA Needle Valve (Opening)
V	X101 Valve Position Indicator
Y	X43 "Y" Strainer

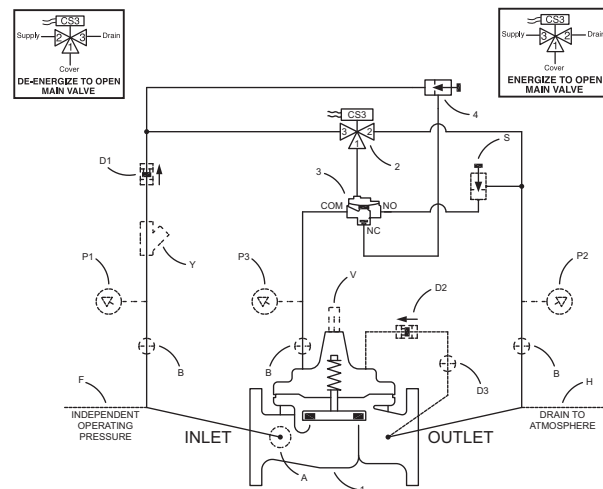

Valves 6" and larger with a "D" check feature must be installed with the main valve stem in a vertical position

### Typical Applications

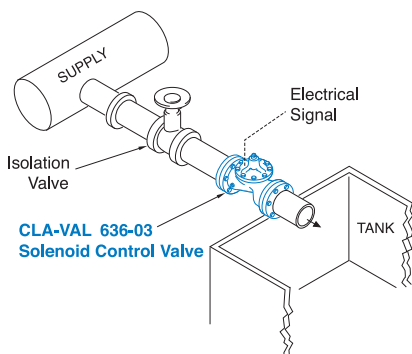

Industrial uses for the solenoid control valve are many and include accurate control of process water for batching, mixing, washing, blending or other on-off type uses.

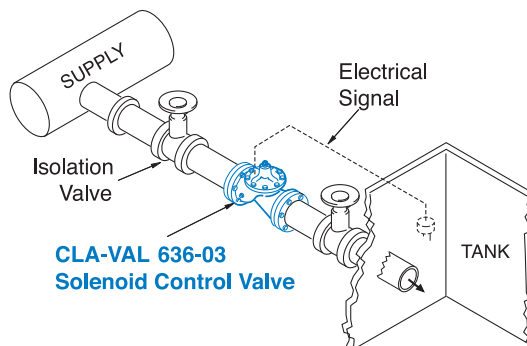

Liquid level control can be provided by using a float switch or electrode probe which sends an electrical signal to open or close the valve as needed.

**Model 636-03** (Uses Hytrol Main Valve Model 100-20)

**Pressure Ratings** (Recommended Maximum Pressure - psi)

Valve Body & Cover		Pressure Class		
		Flanged		
Grade	Material	ANSI Standards*	150 Class	300 Class
ASTM A536	Ductile Iron	B16.42	250	400
ASTM A216-WCB	Cast Steel	B16.5	285	400
UNS 87850	Bronze	B16.24	225	400

Note: \* ANSI standards are for flange dimensions only.  
 Flanged valves are available faced but not drilled.  
**Valves for higher pressure are available; consult factory for details**

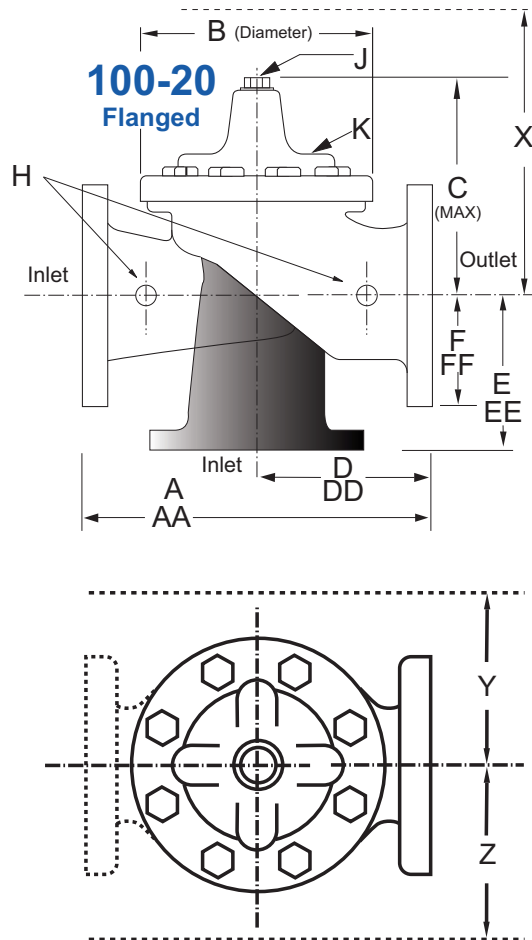

**Materials**

Component	Standard Material Combinations		
Body & Cover	Ductile Iron	Cast Steel	Bronze
Available Sizes	6" - 48" 150 - 1200mm	6" - 16" 150 - 400mm	6" - 16" 150 - 400mm
Disc Retainer & Diaphragm Washer	Cast Iron	Cast Steel	Bronze
Trim: Disc Guide, Seat & Cover Bearing	Bronze is Standard Stainless Steel is Optional		
Disc	Buna-N® Rubber		
Diaphragm	Nylon Reinforced Buna-N® Rubber		
Stem, Nut & Spring	Stainless Steel		

For material options not listed, consult factory.  
 Cla-Val manufactures valves in more than 50 different alloys.

**Model 636-03 Dimensions** (inches)

Valve Size (Inches)	6	8	10	12	14	16	18	20	24	30	36	48
A 150 ANSI	17.75	21.38	26.00	30.00	34.25	35.00	42.12	48.00	48.00	63.25	65.00	88.0
AA 300 ANSI	18.62	22.38	27.38	31.50	35.75	36.62	43.63	49.62	49.75	63.75	67.00	90.62
B Diameter	11.50	15.75	20.00	23.62	27.47	28.00	35.44	35.44	35.44	53.19	56.00	66.00
C Maximum	11.62	15.00	17.88	21.00	20.88	25.75	25.00	31.50	31.50	43.94	54.75	59.00
D 150 ANSI	8.88	10.69	12.75	14.94	—	—	20.93	21.06	—	—	—	—
DD 300 ANSI	9.38	11.19	—	—	—	—	—	—	—	—	—	—
E 150 ANSI	6.75	7.25	8.06	8.68	—	—	15.81	15.94	—	—	—	—
EE 300 ANSI	7.25	7.75	—	—	—	—	—	—	—	—	—	—
F 150 ANSI	5.50	6.75	8.00	9.50	11.00	11.75	15.88	14.56	17.00	19.88	25.50	34.00
FF 300 ANSI	6.25	7.50	8.75	10.25	11.50	12.75	15.88	16.06	19.00	22.00	27.50	38.50
H NPT Body Tapping	0.75	0.75	1.00	1.00	1.00	1.00	1.00	1.00	1.00	1.00	2.00	2.00
J NPT Cover Center Plug	0.75	0.75	1.00	1.00	1.25	1.25	2.00	2.00	2.00	1.00	2.00	2.00
K NPT Cover Tapping	0.75	0.75	1.00	1.00	1.00	1.00	1.00	1.00	1.00	1.00	2.00	2.00
Stem Travel	1.10	1.70	2.30	2.80	3.40	4.50	4.50	4.50	6.50	7.50	7.50	8.50
Approx. Ship Weight (lbs)	195	330	625	900	1250	1380	2365	2551	2733	6500	8545	13100
Approx. X Pilot System	27	30	33	36	36	41	40	46	55	68	79	86
Approx. Y Pilot System	18	20	22	24	26	26	30	30	30	39	40	47
Approx. Z Pilot System	18	20	22	24	26	26	30	30	30	39	42	49

\*Consult Factory

**Model 636-03 Metric Dimensions** (Uses 100-20 Hytrol Main Valve)

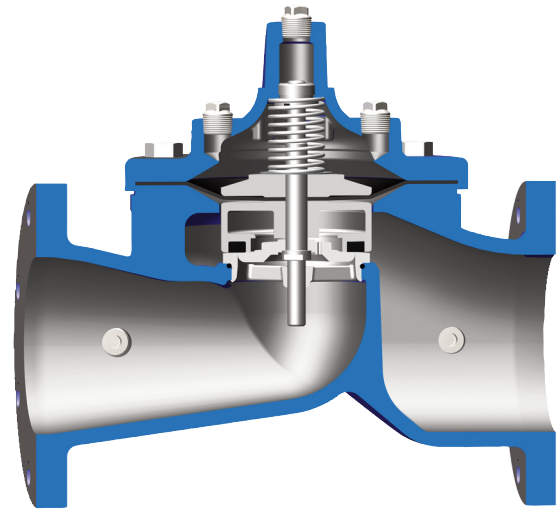
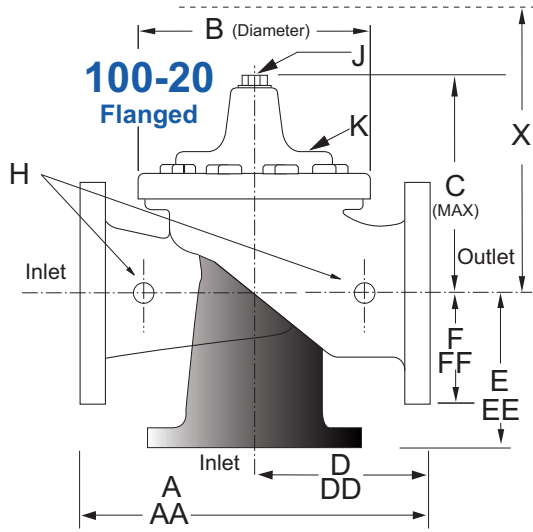

**Model 100-20 Reduced Port Hytrol Main Valve**

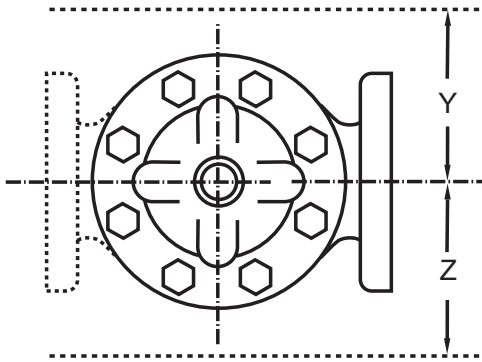

**Model 636-03 Dimensions** (mm)

Valve Size (mm)	150	200	250	300	350	400	450	500	600	750	900	1200
A 150 ANSI	451	543	660	762	870	889	1070	1219	1219	1607	1651	2235
AA 300 ANSI	473	568	695	800	908	930	1108	1260	1263	1619	1702	2302
B Diameter	292	400	508	600	698	711	900	900	900	1351	1422	1676
C Maximum	295	381	454	533	530	654	635	800	800	1116	1391	1499
D 150 ANSI	226	272	324	380	—	—	532	535	—	—	—	—
DD 300 ANSI	238	284	—	—	—	—	—	—	—	—	—	—
E 150 ANSI	171	184	205	349	—	—	402	405	—	—	—	—
EE 300 ANSI	184	197	—	—	—	—	—	—	—	—	—	—
F 150 ANSI	140	171	203	241	279	289	403	370	432	505	648	864
FF 300 ANSI	159	191	222	260	292	324	403	408	483	559	699	978
H NPT Body Tapping	0.75	0.75	1.00	1.00	1.00	1.00	1.00	1.00	1.00	1.00	2.00	2.00
J NPT Cover Center Plug	0.75	0.75	1.00	1.00	1.25	1.25	2.00	2.00	2.00	1.00	2.00	2.00
K NPT Cover Tapping	0.75	0.75	1.00	1.00	1.00	1.00	1.00	1.00	1.00	1.00	2.00	2.00
Stem Travel	28	43	58	71	86	86	114	114	114	165	191	216
Approx. Ship Weight (kgs)	89	150	284	409	568	627	681	1157	1249	2951	3876	5942
Approx. X Pilot System	686	762	839	915	915	1042	1016	1169	1397	1728	2007	2185
Approx. Y Pilot System	458	508	559	610	661	661	762	762	762	991	1016	1194
Approx. Z Pilot System	458	508	559	610	661	661	762	762	762	991	1067	1245

\*Consult Factory

636-03 Valve Selection	100-20 Pattern: Globe (G), Angle (A), End Connections: Flanged (F) Indicate Available Sizes													
	Inches	6	8	10	12	14	16	18	20	24	30	36	42	48
	mm	150	200	250	300	350	400	450	500	600	750	900	1000	1200
Main Valve 100-20	Pattern	G, A	G, A	G	G	G	G	G	G	G	G	G	G	G
	End Detail	F	F	F	F	F	F	F	F	F	F	F	F	F
Suggested Flow (gpm)	Maximum	1025	2300	4100	6400	9230	9230	16500	16500	16500	28000	33500	33500	33500
Suggested Flow (Liters/Sec)	Maximum	65	145	258	403	581	581	1040	1040	1040	1764	2115	2115	2115

100-20 Series is the reduced internal port size version of the 100-01 Series.

## Pilot System Specifications

### Temperature Range

Water: to 180°F/82°C

### Fluids

Air, water, light oils

### Solenoid Control

Body:

Brass ASTM B283

Rubber Parts:

Buna-N® Synthetic Rubber

Enclosure:

NEMA Type 1,2,3,3S,4,4X general purpose watertight\*

NEMA Type 6,6P,7,9 watertight Explosion Proof available.

Voltages:

110, 220 - 50Hz AC

24, 120, 240, 480 - 60Hz AC

6, 12, 24, 120, 240 - DC

Others available at additional cost

Max. operating pressure differential:

200 psi\*

Coil:

Insulation molded Class F

Watts AC 6

AC Volt Amps Inrush 30

AC Volt Amps Holding 16

Watts DC 10.6

Manual operator available at additional cost.

\*Supplied unless otherwise specified

Note: Flowing Pressure Differential: 5 psi minimum

### When Ordering, Specify

- Catalog No. 636-03
- Valve Size
- Pattern - Globe or Angle
- Pressure Class
- Threaded or Flanged
- Materials Desired
- Energized or de-energized to open Main Valve
- Solenoid Enclosure, Voltage & Hertz, Coil Insulation, and Max. Operating Pressure Differential
- Desired Options
- When Vertically Installed

### Valve Options

X141 Pressure Gauge



X101AR Valve Position Indicator with Air Release



X101 Valve Position Indicator



X144 e-FlowMeter



X43H Strainer



Stainless Steel Pilot

