



— MODEL — **660-BY**

Booster Pump Control Valve with High Capacity Solenoid Control



- Simple Hydraulic Operation
- Low Head Loss
- Built-in Check Valve
- Proven Reliable Design

The Cla-Val Model 660-BY Booster Pump Control valve is a pilot-operated valve designed for installation on the discharge of booster pumps to eliminate pipeline surges caused by the starting and stopping of the pump.

The pump starts against a closed valve. When the pump is started, the solenoid control is energized and the valve begins to open slowly, gradually increasing line pressure to full pumping head. When the pump is signaled to shut-off, the solenoid control is de-energized and the valve begins to close slowly, gradually reducing flow while the pump continues to run. When the valve is closed, a limit switch assembly, which serves as an electrical interlock between the valve and the pump, releases the pump starter and the pump stops.

The Model 660-BY is an automatic valve of a modified globe-type design with a built-in, lift type, check feature. It is hydraulically operated and diaphragm-actuated. The CSM11-HC solenoid valve controls the valve operation.

Schematic Diagram

Item	Description
1	Hycheck Main Valve 100-23
2	CSM11-HC Solenoid Control
3	X105LCW Switch Assembly
4	CDC Check Valve
5	CDC/CSC Check valve
6	CK2 Isolation Valve
7	CNA Needle Valve

Optional Features

Item	Description
A	X46A Flow Clean Strainer
B	CK2 Isolation Valve
P	X141 Pressure Gauge
Y	X43 "Y" Strainer

Note: For main valve option descriptions, refer to the 100-04 Engineering Data Sheet.

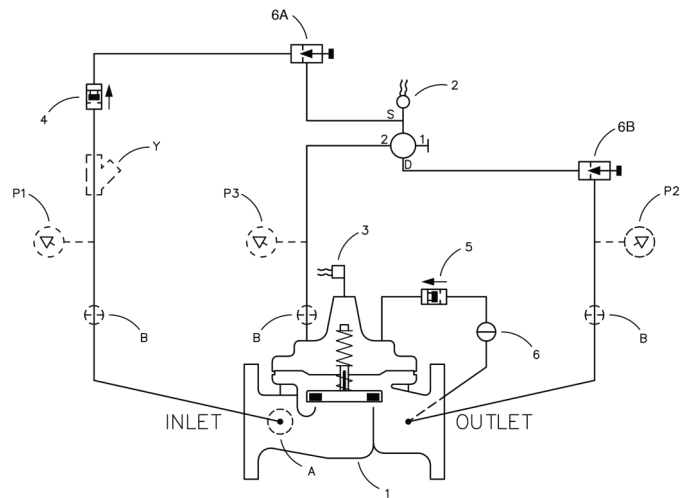

Typical Application

Install Model 660-BY valve as shown in multiple pump applications. Flexible conduit should be used for electrical connections to the solenoid control and the limit switch. A Model 52-03/652-03 Surge Anticipator Valve is recommended for power failure protection.

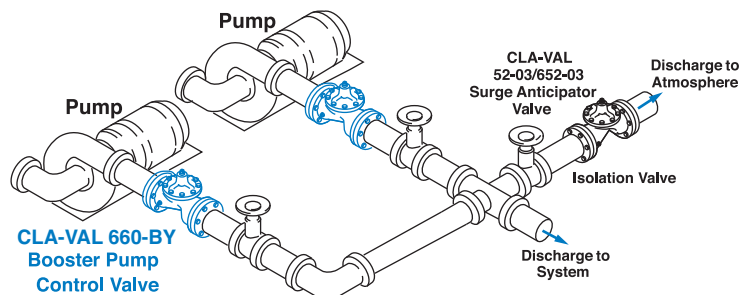

Pressure Ratings (Recommended Maximum Pressure - psi)

Valve Body & Cover		Pressure Class		
		Flanged		
Grade	Material	ANSI Standards*	150 Class	300 Class
ASTM A536	Ductile Iron	B16.42	250	400
ASTM A216-WCB	Cast Steel	B16.5	285	400
UNS 87850	Bronze	B16.24	225	400

Note: * ANSI standards are for flange dimensions only.
Flanged valves are available faced but not drilled.

Materials

Component	Standard Material Combinations		
	Ductile Iron	Cast Steel	Bronze
Body & Cover	Ductile Iron	Cast Steel	Bronze
100-23 Inches	8" - 16"	8" - 16"	8" - 16"
100-23 Metric	200 - 400 mm	200 - 400 mm	200 - 400 mm
Disc Retainer & Diaphragm Washer	Cast Iron	Cast Steel	Bronze
Trim: Disc Guide, Seat & Cover Bearing	Bronze is Standard Stainless Steel is Optional		
Disc	Buna-N® Rubber		
Diaphragm	Nylon Reinforced Buna-N® Rubber		
Stem, Nut & Spring	Stainless Steel		

For material options not listed, consult factory.
Cla-Val manufactures valves in more than 50 different alloys.

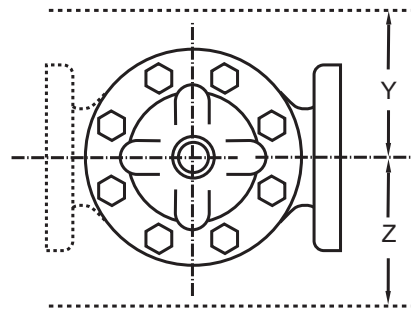
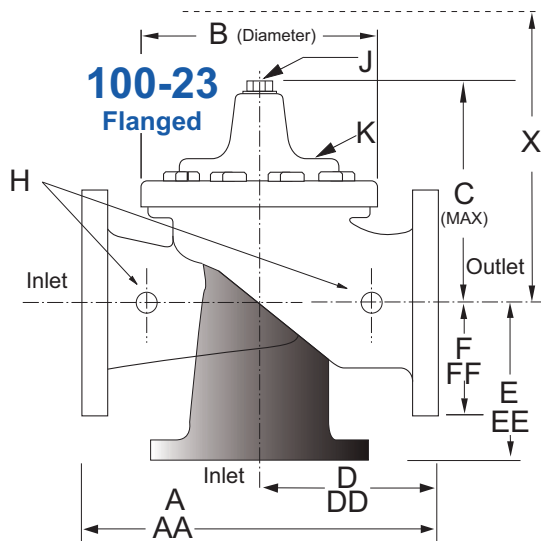

660-BY Series Dimensions (Uses HyCheck Main Valve 100-23) (inches)

Valve Size (Inches)	8	10	12	14	16
A 150 ANSI	21.38	26.00	30.00	34.25	35.00
AA 300 ANSI	22.38	27.38	31.50	35.75	36.62
B Diameter	15.75	20.00	23.62	27.47	28.00
C Maximum	15.00	17.88	21.00	20.88	25.75
D 150 ANSI	10.69	—	—	—	—
DD 300 ANSI	11.19	—	—	—	—
E 150 ANSI	7.25	—	—	—	—
EE 300 ANSI	7.75	—	—	—	—
F 150 ANSI	6.75	8.00	9.50	11.00	11.75
FF 300 ANSI	7.50	8.75	10.25	—	12.75
H NPT Body Tapping	0.75	1.00	1.00	1.00	1.00
J NPT Cover Center Plug	0.75	1.00	1.00	1.25	1.25
K NPT Cover Tapping	0.75	1.00	1.00	1.00	1.00
Stem Travel	1.70	2.30	2.80	3.40	3.40
Approx. Ship Weight (lbs)	330	625	900	1250	1380
Approx. X Pilot System	30.00	33.00	36.00	36.00	41.00
Approx. Y Pilot System	20.00	22.00	24.00	26.00	26.00
Approx. Z Pilot System	20.00	22.00	24.00	26.00	26.00

660-BY Series Metric Dimensions (Uses Hycheck Main Valve 100-23) (mm)

Valve Size (mm)	200	250	300	350	400
A 150 ANSI	543	660	762	870	889
AA 300 ANSI	568	695	800	908	930
B Diameter	400	508	600	698	711
C Maximum	381	454	533	530	654
D 150 ANSI	272	CF*	CF*	CF*	CF*
DD 300 ANSI	284	CF*	CF*	CF*	CF*
E 150 ANSI	184	CF*	CF*	CF*	CF*
EE 300 ANSI	197	CF*	CF*	CF*	CF*
F 150 ANSI	171	203	241	279	298
FF 300 ANSI	191	222	260	—	324
H NPT Body Tapping	0.75	1.00	1.00	1.00	1.00
J NPT Cover Center Plug	0.75	1.00	1.00	1.25	1.25
K NPT Cover Tapping	0.75	1.00	1.00	1.00	1.00
Stem Travel	43	58	71	86	86
Approx. Ship Weight (kgs)	150	284	409	568	627
Approx. X Pilot System	762	838	914	914	1041
Approx. Y Pilot System	508	559	610	660	660
Approx. Z Pilot System	508	559	610	660	660

Model 660-BY Flow Chart (Uses Main Valve Model 100-23)

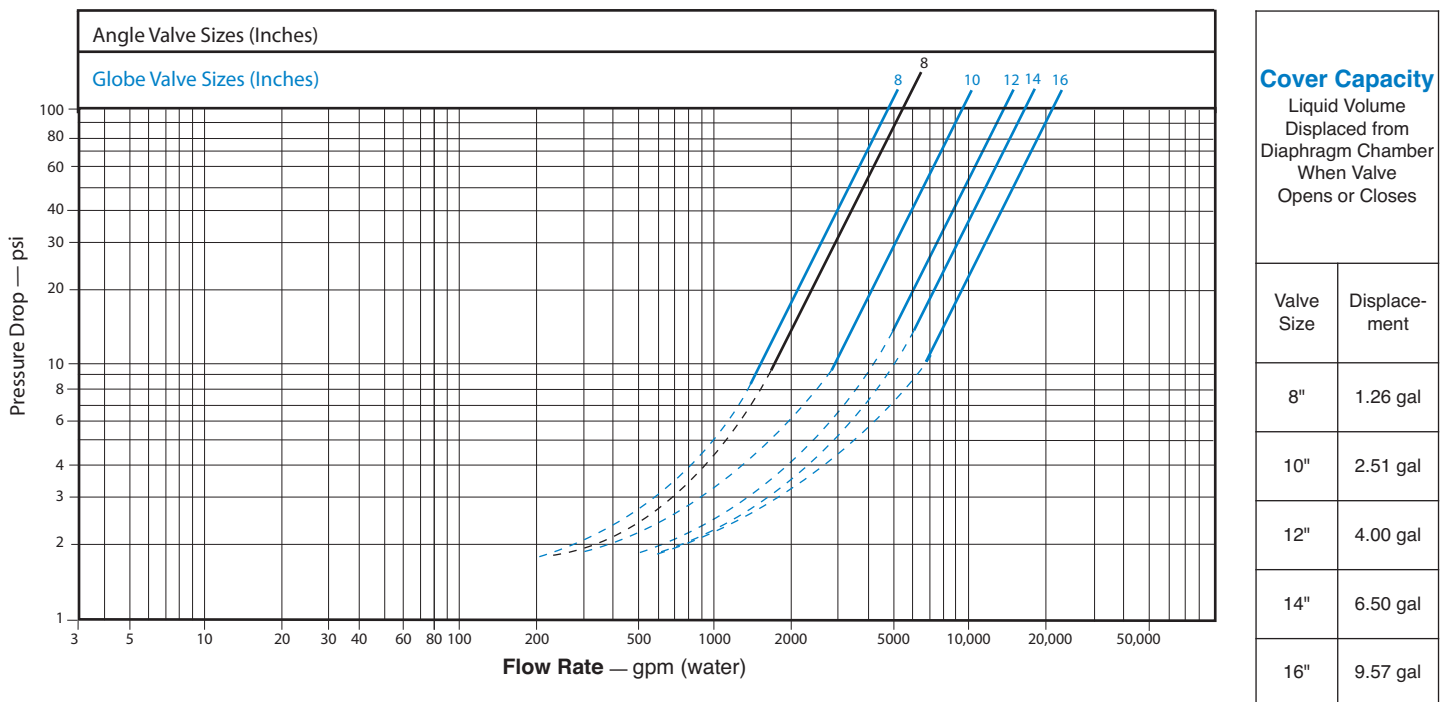

When Ordering, Please Specify:

1. Catalog No. 660-BY
2. Valve Size
3. Pattern - Globe or Angle
4. Pressure Class (Flanged)
5. Trim Material
6. Electrical Selection
7. Desired Options
8. When Vertically Installed (Flow Direction)

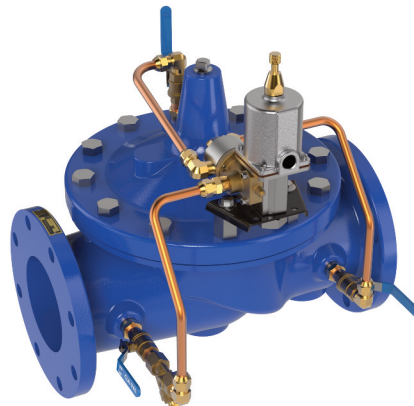

660-BY Valve Selection	100-23 Pattern: Globe (G), Angle (A), End Connections: Threaded (T), Flanged (F) Indicate Available Sizes					
	Inches	8	10	12	14	16
	mm	200	250	300	350	400
Main Valve 100-23	Pattern	G, A	G	G	G	G
	End Detail	F	F	F	F	F
Suggested Flow (gpm)	Maximum	2300	4100	6400	9230	9230
	Maximum Intermittent	145	258	403	581	581
Suggested Flow (Liters/Sec)	Maximum	195	309	442	530	694
	Maximum Intermittent	246	387	549	664	863

100-23 Series is the reduced internal port Hycheck.

CSM11-HC Solenoid Control Power Consumption

Volts	Amperes		Coil Resistance Ohms
	Holding	Inrush	
AC 60 Hz			
24	2.88	25.4	0.5
120	.575	5.1	14.1
208	.330	2.93	40
240	.288	2.54	58
440	.156	1.38	174
440	.143	1.27	233
Volts	Amperes		Coil Resistance Ohms
	Holding	Inrush	
(AC 50 Hz)			
110	.48	4.6	15.7
220	.24	2.3	66
240	.22	2.1	88



CSM11-HC Specifications

Enclosure General purpose NEMA Type 3; Aluminum
Note: For other enclosures and NEMA Types, consult factory

Housing Body — Aluminum
Trim — Stainless Steel

Operating Pressure: Maximum pressure 300 psi, for higher pressure consult factory.

Coil Insulation Class A (molded)

AC voltage 15.4 watts

Pilot System Specifications

Temperature Range

Water to 180°F / 82°C Max

Materials

Standard Pilot System Materials

Pilot Control: Low Lead Bronze

Trim: Stainless Steel Type 303

Rubber: Buna-N® Synthetic Rubber

Optional Pilot System Materials

Pilot Systems are available with optional Aluminum, Stainless Steel or Monel materials.

Wiring Diagram

Auto-Off-Hand	= Selector Switch
1CR	= Relay, DPST Normally Open
2CR	= Relay, DPST Normally Open
3CR	= Relay, TPST Normally Open
SW ₁	= Switch, Remote Start, Automatic
SW ₂	= Switch, SPDT, Valve Limit Switch Connect to N.C. Terminal
PVS	= Pilot Valve Solenoid
M	= Pump Motor Starter

Note: SW₂ and PVS supplied by Cla-Val. All other electrical items supplied by customer. SW₂ is included in the X105L switch assembly which is mounted on the pump control valve cover.

Shown In Pump Off Position

