



— MODEL — 3690-07

Electronic Actuated Pressure Reducing Valve



- Simplified Remote Valve Set-Point Control
- Ideal for use with VC-22D Electronic Valve Controller
- 12 to 24 VDC Input Power
- Isolated Input
- Reverse Polarity Protection
- Reliable Hydraulic Operation
- IP-68 (Submersible)

The Cla-Val Model 3690-07 Electronic Actuated Pressure Reducing Control Valve combines precise control of field proven Cla-Val hydraulic pilots and simple, remote valve control. The Cla-Val Model 3690-07 Pressure Reducing Valve automatically reduces a higher inlet pressure to a steady lower downstream pressure regardless of changing flow rate and/or varying inlet pressure. This valve is an accurate, pilot-operated regulator capable of holding downstream pressure to a pre-determined limit. The valve uses a CRD-34 pilot control, consisting of a hydraulic pilot and integral controller, that accepts a remote set-point command input and makes set-point adjustments to the pilot.

Schematic Diagram

Item	Description
1	100-01 Hytrol Main Valve
2	X58C Restriction Fitting
3	CRD-34 Electronic Pressure Reducing Control
4	CRD Pressure Reducing Control
5	CK2 Isolation Valve

Optional Features

Item	Description
A	X46A Flow Clean Strainer
B	CK2 Isolation Valve
C	CV Flow Control (Closing)
D	Check Valves with Isolation Valve
P	X141 Pressure Gauge
S	CV Flow Control (Opening)
V	X101 Valve Position Indicator
Y	X43 "Y" Strainer

The recommended control method is simple remote set-point change from an RTU (Remote Telemetry Unit) to the CRD-34 where the 4-20 mA command signal is ranged to specific pressure range. Very accurate control can be achieved when span does not exceed 100 psi. Since the CRD-34 is pre-ranged to the full spring range, some on-site calibration may be necessary when this control method is used. Free downloadable software is available from Cla-Val website for this purpose. The CRD-34 can also accommodate control systems where the RTU compares pressure transmitter signal to the remote set point command signal. The RTU adjusts the CRD-34 with 4-20 mA command signal containing an adequate deadband to prevent actuator dithering after the two signals agree.

Internal continuous electronic monitoring of actuator position results in virtually instantaneous position change with no backlash or dithering when control signal is changed. In the event of a power or control input failure, the CRD-34 pilot remains in hydraulic control virtually assuring system stability under changing conditions. If check feature ("D") is added, and pressure reversal occurs, the valve closes to prevent return flow.

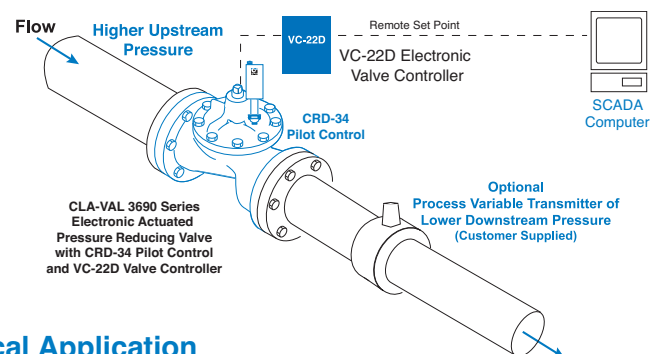
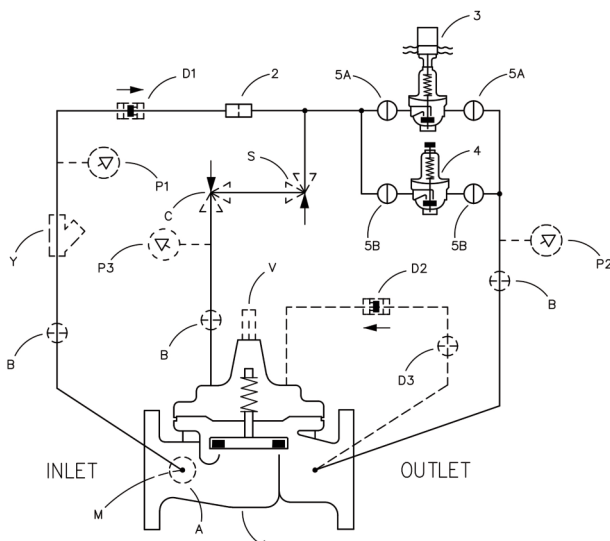

Typical Application

The Cla-Val 3690 Series valves that maintain downstream pressure and require this pressure to be changed from a remote location. It can be an effective solution for lowering costs associated with "confined space" requirements by eliminating the need for entry in valve structure for set-point adjustment. It is also ideal for pressure management, and can be programmed to minimum night time and optimum daytime pressures.

Model 3690-07 (Uses Hytrol Main Valve 100-20)

Pressure Ratings (Recommended Maximum Pressure - psi)

Valve Body & Cover		Pressure Class				
		Flanged			Grooved	Threaded
Grade	Material	ANSI Standards*	150 Class	300 Class	300 Class	End‡ Details
ASTM A536	Ductile Iron	B16.42	250	400	400	400
ASTM A216-WCB	Cast Steel	B16.5	285	400	400	400
UNS 87850	Bronze	B16.24	225	400	400	400

Note: * ANSI standards are for flange dimensions only.
 Flanged valves are available faced but not drilled.
 ‡ End Details machined to ANSI B2.1 specifications.
Valves for higher pressure are available; consult factory for details

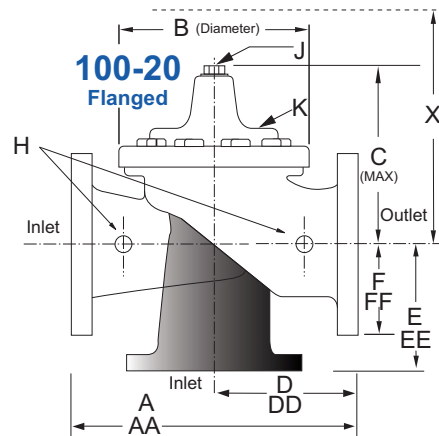

Materials

Component	Standard Material Combinations		
Body & Cover	Ductile Iron	Cast Steel	Bronze
Available Sizes (inches)	3" - 48"	3" - 16"	3" - 16"
Available Sizes (mm)	80 - 900 mm	80 - 400 mm	80 - 400mm
Disc Retainer & Diaphragm Washer	Cast Iron	Cast Steel	Bronze
Trim: Disc Guide, Seat & Cover Bearing	Bronze is Standard Stainless Steel is Optional		
Disc	Buna-N® Rubber		
Diaphragm	Nylon Reinforced Buna-N® Rubber		
Stem, Nut & Spring	Stainless Steel		

For material options not listed, consult factory.
 Cla-Val manufactures valves in more than 50 different alloys.

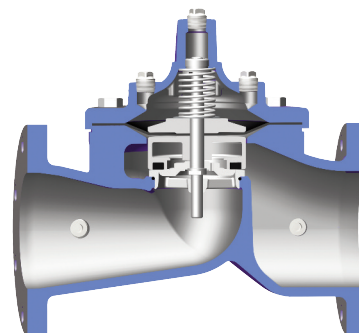
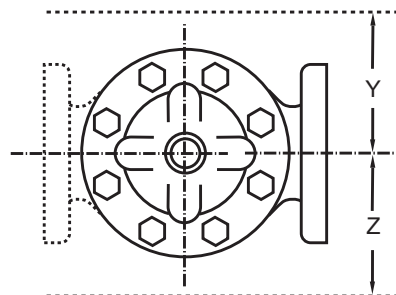

100-20 Hytrol Main Valve - Reduced Port

Model 3690-07 Dimensions (inches)

Valve Size (Inches)	3	4	6	8	10	12	14	16	18	20	24	30	36	48
A 150 ANSI	10.25	13.88	17.75	21.38	26.00	30.00	34.25	35.00	42.12	48.00	48.00	63.25	65.00	88.0
AA 300 ANSI	11.00	14.50	18.62	22.38	27.38	31.50	35.75	36.62	43.63	49.62	49.75	63.75	67.00	90.62
B Diameter	6.62	9.12	11.50	15.75	20.00	23.62	27.47	28.00	35.44	35.44	35.44	53.19	56.00	66.00
C Maximum	7.00	8.62	11.62	15.00	17.88	21.00	20.88	25.75	25.00	31.50	31.50	43.94	54.75	59.00
D 150 ANSI	—	6.94	8.88	10.69	12.75	14.94	—	—	20.93	21.06	—	—	—	—
DD 300 ANSI	—	7.25	9.38	11.19	—	—	—	—	—	—	—	—	—	—
E 150 ANSI	—	5.50	6.75	7.25	8.06	8.68	—	—	15.81	15.94	—	—	—	—
EE 300 ANSI	—	5.81	7.25	7.75	—	—	—	—	—	—	—	—	—	—
F 150 ANSI	3.75	4.50	5.50	6.75	8.00	9.50	11.00	11.75	15.88	14.56	17.00	19.88	25.50	34.00
FF 300 ANSI	4.12	5.00	6.25	7.50	8.75	10.25	11.50	12.75	15.88	16.06	19.00	22.00	27.50	38.50
H NPT Body Tapping	0.375	0.50	0.75	0.75	1.00	1.00	1.00	1.00	1.00	1.00	1.00	1.00	2.00	2.00
J NPT Cover Center Plug	0.50	0.50	0.75	0.75	1.00	1.00	1.25	1.25	2.00	2.00	2.00	1.00	2.00	2.00
K NPT Cover Tapping	0.375	0.50	0.75	0.75	1.00	1.00	1.00	1.00	1.00	1.00	1.00	1.00	2.00	2.00
Stem Travel	0.60	0.80	1.10	1.70	2.30	2.80	3.40	4.50	4.50	4.50	6.50	7.50	7.50	8.50
Approx. Ship Weight (lbs)	45	85	195	330	625	900	1250	1380	2365	2551	2733	6500	8545	13100
Approx. X Pilot System	13	15	27	30	33	36	36	41	40	46	55	68	79	86
Approx. Y Pilot System	10	11	18	20	22	24	26	26	30	30	30	39	40	47
Approx. Z Pilot System	10	11	18	20	22	24	26	26	30	30	30	39	42	49

Note: The top two flange holes on valve size 36 are threaded to 1 1/2"-6 UNC.

Model 3690-07 Metric Dimensions (Uses Main Valve Model 100-20)

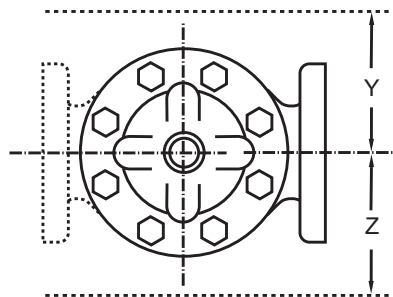
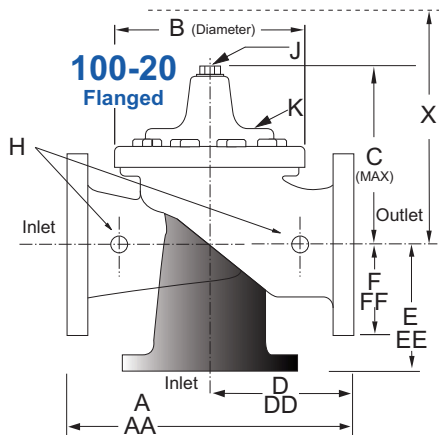

Valve Size (mm)	80	100	150	200	250	300	350	400	450	500	600	750	900	1200
A 150 ANSI	260	353	451	543	660	762	870	889	1070	1219	1219	1607	1651	2235
AA 300 ANSI	279	368	473	568	695	800	908	930	1108	1260	1263	1619	1702	2302
B Diameter	168	232	292	400	508	600	698	711	900	900	900	1351	1422	1676
C Maximum	178	219	295	381	454	533	530	654	635	800	800	1116	1391	1499
D 150 ANSI	—	176	226	272	324	380	—	—	532	535	—	—	—	—
DD 300 ANSI	—	184	238	284	—	—	—	—	—	—	—	—	—	—
E 150 ANSI	—	140	171	184	205	349	—	—	402	405	—	—	—	—
EE 300 ANSI	—	148	184	197	—	—	—	—	—	—	—	—	—	—
F 150 ANSI	95	114	140	171	203	241	279	289	403	370	432	505	648	864
FF 300 ANSI	105	127	159	191	222	260	292	324	403	408	483	559	699	978
H NPT Body Tapping	0.375	0.50	0.75	0.75	1.00	1.00	1.00	1.00	1.00	1.00	1.00	1.00	2.00	2.00
J NPT Cover Center Plug	0.50	0.50	0.75	0.75	1.00	1.00	1.25	1.25	2.00	2.00	2.00	1.00	2.00	2.00
K NPT Cover Tapping	0.375	0.50	0.75	0.75	1.00	1.00	1.00	1.00	1.00	1.00	1.00	1.00	2.00	2.00
Stem Travel	15	20	28	43	58	71	86	86	114	114	114	165	191	216
Approx. Ship Weight (kgs)	20	39	89	150	284	409	568	627	681	1157	1249	2951	3876	5942
Approx. X Pilot System	331	381	686	762	839	915	915	1042	1016	1169	1397	1728	2007	2185
Approx. Y Pilot System	254	280	458	508	559	610	661	661	762	762	762	991	1016	1194
Approx. Z Pilot System	254	280	458	508	559	610	661	661	762	762	762	991	1067	1245



Valve Options

X141 Pressure Gauge



X144 e-FlowMeter



X101AR Valve Position Indicator with Air Release



X101 Valve Position Indicator



X43H Strainer



Stainless Steel Pilot

3690-07 Valve Selection	100-20 Pattern: Globe (G), Angle (A), End Connections: Flanged (F) Indicate Available Sizes															
	Inches	3	4	6	8	10	12	14	16	18	20	24	30	36	42	48
	mm	80	100	150	200	250	300	350	400	450	500	600	750	900	1000	1200
Main Valve 100-20	Pattern	G	G, A	G, A	G, A	G	G	G	G	G	G	G	G	G	G	G
	End Detail	F	F	F	F	F	F	F	F	F	F	F	F	F	F	F
Suggested Flow (gpm)	Maximum	260	580	1025	2300	4100	6400	9230	9230	16500	16500	16500	28000	33500	33500	33500
	Minimum	1	2	4	10	15	35	50	50	95	95	95	275	450	450	450
Suggested Flow (Liters/Sec)	Maximum	16	37	65	145	258	403	581	581	1040	1040	1040	1764	2115	2115	2115
	Minimum	.06	.13	.25	.63	.95	2.2	3.2	3.2	6.0	6.0	6.0	17.4	28.4	41.0	41.0

100-20 Series is the reduced internal port size version of the 100-01 Series.

For Lower Flows Consult Factory

We recommend providing adequate space around valve for maintenance work



CRD-34 Overview

The Cla-Val Model CRD-34 and CRA-34 Electronic Actuated Pressure Reducing Pilot Controls provide remote set-point adjustment and accurate downstream pressure control on Cla-Val 390 Series Control Valves. Remote set-point command signals can be from any SCADA-type control system using an analog 4-20 mA signal, by contact closure for cc/ccw rotation or through Modbus RTU.

The CRD-34 senses valve outlet pressure directly and the CRA-34 senses downstream pressure with remote hydraulic connection. Operating on 12 - 24 VDC and consuming very little power, they are an ideal control system for remote valve sites that may even be solar powered. Existing manually-set Cla-Val 90 Series Pressure Reducing control valves can be retrofitted with CRD-34 or CRA-34 to add remote set-point control of delivery pressure. Verification of downstream pressure may be sent to SCADA system from customer supplied pressure sensor attached to valve outlet.

CRD-34 Subassembly Specifications

Adjustment Ranges

- 2 to 30 psi
- 15 to 75 psi
- 20 to 105 psi
- 40 to 140 psi

End Connection

3/8" NPT

Temperature Range

Water: to 180°F

Materials

- Pilot Control: Low Lead Bronze
- Trim: Stainless Steel Type 303
- Rubber: Buna-N® Synthetic Rubber

Available with optional Stainless Steel or Monel materials. Consult factory for details.

Note: Available with remote sensing control (specify CRA-34)

When Ordering, Specify:

- | | |
|-----------------------------|------------------------------|
| 1. Catalog No. 3690-07 | 6. Trim Material |
| 2. Valve Size | 7. Adjustment Range |
| 3. Pattern - Globe or Angle | 8. Desired Options |
| 4. Pressure Class | 9. When Vertically Installed |
| 5. Threaded or Flanged | |

CRD-34 Actuator Specifications

Supply Power Input:

12 to 24 VDC
No Load draw: 50 mA
Max. Load draw: 250 mA

Remote Command Inputs:

- 4-20mA, analog signal (isolated and reverse-polarity protected)
- Dry contact closure (CW/CCW)

Position Feedback Signal:

4-20 mA

Alarm Output:

Dry-contact closure (High/Low)

Speed of Rotation:

Adjustable On/Off time, max 6 rpm

Diagnostic:

LED Indicator

Loss of Power:

Actuator will remain in last commanded position.

Loss of Signal Position:

Programmable - 4 mA, Last, or 20 mA

Electrical Connections:

Single, 30 feet of permanently attached cable with color-coded power supply and signal wires

Mechanical Specifications:

Environmental

Protection Class: IP-68 (Temporary submersible)
Ambient Temperature: 15° to 150° F (-10° to 65° C)

Materials

Electronics Enclosure: Anodized Aluminum
Mechanical Housing: Bronze
Coupling Assembly: Stainless Steel
Gear Train: Stainless Steel, permanently lubricated