

# STAN-COR

*Sealed ANSI Design  
Centrifugal Pumps Molded  
from Solid Kynar®*



*Designed specifically for dirty,  
abrasive and corrosive process fluids*

 **Wanner Engineering, Inc.**

- **Designed by the process industry for the process industry**
- **Cost-effective, rugged and durable design**
- **Smooth, full-curve performance**

## Applications

Stan-Cor Series pumps are specifically designed to handle abrasive, corrosive, dirty and reclaim process fluids like no other pump can:

- Acid recovery
- Bleaching
- Chlorinated hydrocarbon
- Grit removal
- Hydrochloric acid
- Hydrofluoric w/lime
- Lime slurries
- Paints
- Pickling solutions
- Plating solutions
- Semi-conductor waste water
- Sodium hydroxide
- Spent caustics
- Sulfuric acid

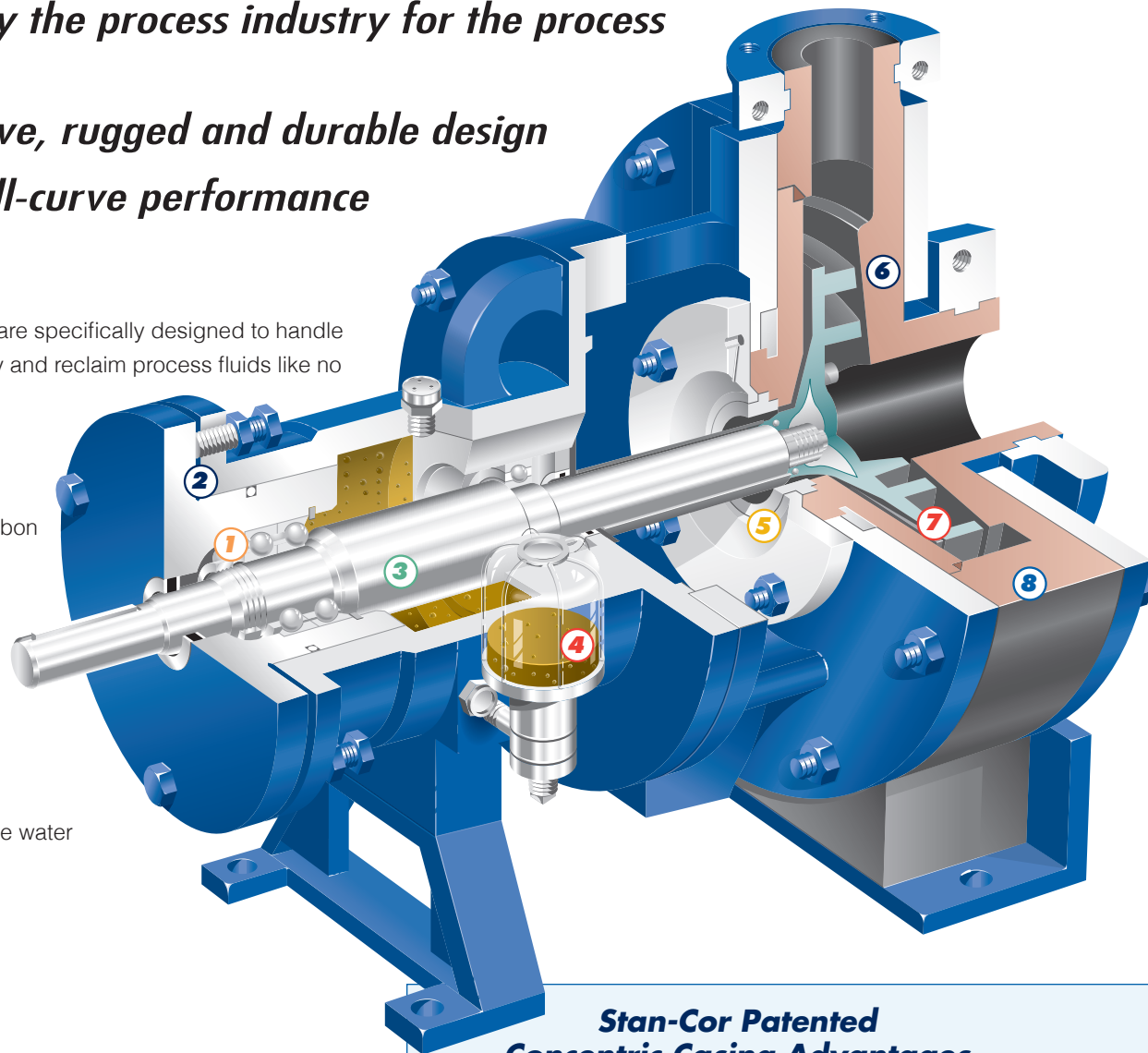

## Design Benefits

- Solid Kynar\* pump head for chemical compatibility and excellent abrasion resistance
- Concentric casing design for better flow patterns than other centrifugal pumps– less turbulence, longer seal life, reduced shaft deflection
- Handles high temperatures up to 250°F
- Compact design features including heavy-duty drive shaft, adjustable bearing supports, and large-capacity oil bath to ensure low maintenance and durable performance for the toughest fluid applications
- Back pull-out design for easy servicing
- Handles solid sizes up to 9/16" maximum

## Stan-Cor Patented Concentric Casing Advantages

Unlike volute-type centrifugal pumps, the Stan-Cor pump uses a unique concentric design that provides a constant, equal distance between the pump casing and the impeller at all times during pump operation. This greatly reduces turbulence and vibration, thereby extending the life of the mechanical seal and bearings.

In a conventional volute casing pump, water turbulence and eddies are created as the impeller passes the restrictive cut water area in the casing. These hydraulic imbalances in turn cause the drive shaft to deflect, which increases the loading on the bearings, and leads to premature mechanical seal failure. At near shut-off, the bearing loading is extremely high.

\*Kynar is Elf-Atochem's registered trademark for its vinylidene fluoride plastic.

**Stan-Cor Series pumps provide exclusive design advantages over all other centrifugal pumps.**

*For applications requiring durability and performance on dirty, difficult fluids, Stan-Cor pumps are by far the most cost-effective solution.*

## ① Heavy-duty Bearings

Stan-Cor's duplex angular contact thrust bearings in the rear withstand far greater radial and axial thrust than conventional bearings.

## ② Bearing Housing

External adjustment of rear bearing housing is used to set impeller clearance ensuring zero end play for maximum mechanical seal life.

## ③ Optimized Shaft Design

Optimized shaft design features maximum diameter-to-length ratio, minimal overhang, and extra heavy-duty support to minimize shaft deflection and associated seal wear.

## ④ Oil Bath Reservoir

Oil bath reservoir with overflow sight glass keeps bearings fully lubricated.

## ⑤ Seal Options

Component and cartridge seal options available.

## ⑥ Materials of Construction

Kynar 370, a carbon-filled PVDF material is thermally stable to maintain tight dimensions.

## ⑦ Impeller

Molded from solid Kynar 370, Stan-Cor semi-open tapered impellers are machined to the exact diameter required to control performance. Additional back pump out vanes produce low stuffing box pressures and keep seal area clear of debris.

## ⑧ Casing

Stan-Cor pumps have a concentric casing (see illustration below), which greatly reduces turbulence and vibration, extends seal and bearing life, eliminates excessive hydraulic imbalances and allows the pump to run anywhere between a few gpm to maximum flow without undue shaft deflection. The design allows the Stan-Cor pump to handle abrasives much better than standard open impeller centrifugal pumps.

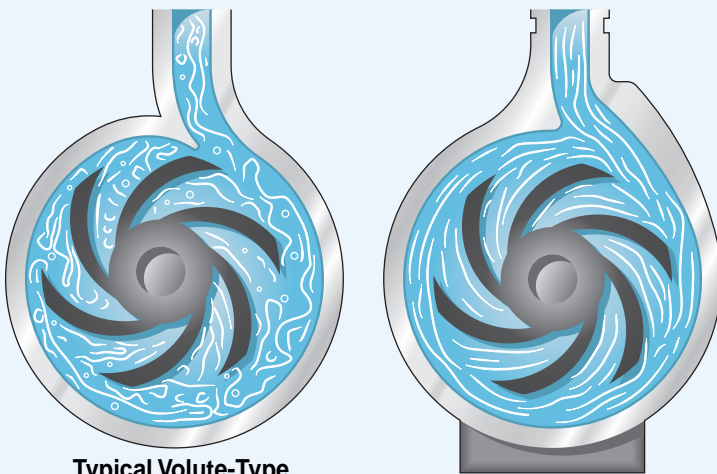

**Typical Volute-Type Centrifugal Pump**  
showing excessive turbulence and eddies

**STAN-COR Concentric Casing Pump**  
showing smooth flow pattern

The Stan-Cor concentric casing design eliminates these excessive hydraulic imbalances. ***It allows the pump to run anywhere between a few gallons per minute and full flow without undue shaft deflection.*** Moreover, the design allows the Stan-Cor pump to handle abrasives much better than standard models.

The sharp, restrictive cut water area of most pumps is the focal point for corrosion and erosion. It is the place where abrasives first attack a pump. With lined pumps, the thin liner is easily abraded away and the metallic backing exposed to the corrosive and abrasive forces of the product being pumped. The Stan-Cor concentric casing design, coupled with its solid homogenous non-metallic component, eliminates this problem area.

# PERFORMANCE AND SELECTION

- **Total Dynamic Head to 350 Feet**
- **Flow Rates to 700 gpm**

Stan-Cor ANSI Centrifugal Pumps are *the standard* for corrosion resistance and abrasive fluids. They offer *solid* fluid ends (casing, back cover and impeller) in two different materials for chemical resistance and temperature limits. Because these sections are solid in Stan-Cor pumps, there is no loss of corrosion resistance from abrasion, dents, gouges, cavitation, vacuum, turbulence and permeability. Corrosive materials do not come in contact with any metal parts of the pump.



## Selection

Use the selection chart below to determine the appropriate Stan-Cor pump model and size for your application. Please contact Wanner Engineering or your local Stan-Cor distributor for exact sizing of a Stan-Cor pump to your specific application requirements.

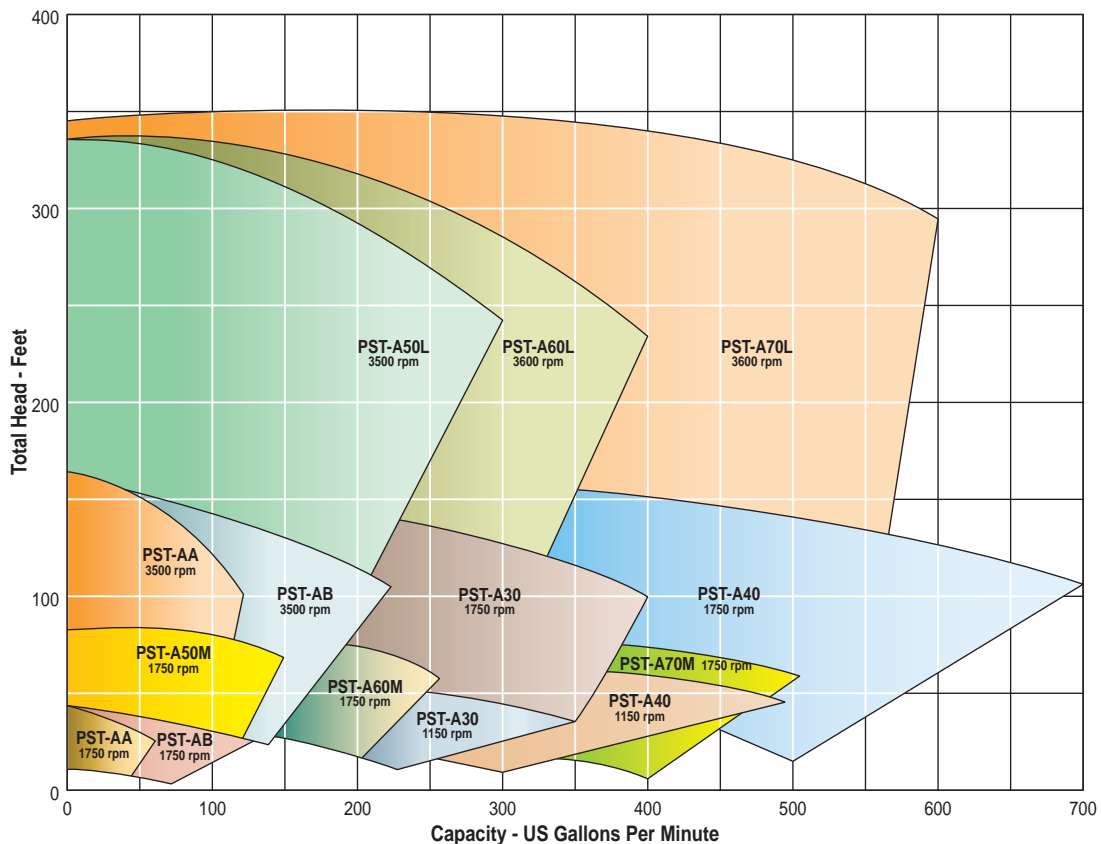

## Metal-to-Metal Impeller/Shaft Sleeve

On the standard Stan-Cor Kynar pump design, the drive shaft is protected by a Kynar-encased sleeve that threads directly into the impeller hub. An o-ring seals the area between the Kynar of the impeller and the Kynar of the shaft sleeve to ensure that corrosive process fluids do not come into contact with any metallic parts.

**For added protection on demanding applications which utilize impellers over 9" in diameter, the Stan-Cor PST-A60M, PST-A30 and PST-A40 can be fitted with an optional MTM impeller/sleeve design in which the metal insert of the shaft sleeve extends around the drive shaft.**

When the shaft is threaded into the impeller and tightened, this sleeve extension forms a solid metal-to-metal contact with the impeller hub for added impeller stability.

Standard Sleeve Design

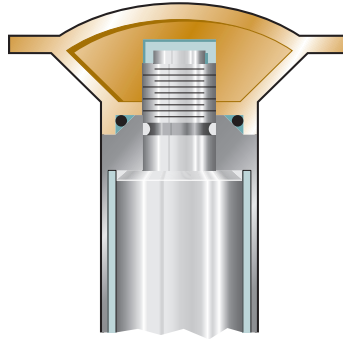

Metal-to-Metal Sleeve Design

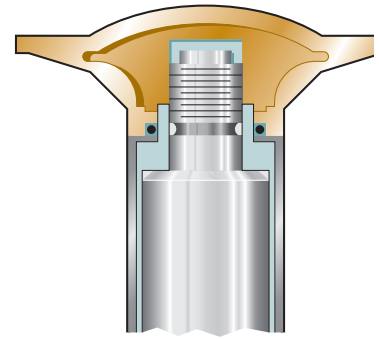

For strenuous pump applications in which the pump undergoes excessive cavitation or in which the pump is allowed to "run off the curve" because of low head and high flow requirements, the MTM option provides the added impeller stability to help avoid the possibility of excessive impeller deflection.

If occasional conditions as described earlier occur in the application, the MTM design option should be considered to help protect the pump from damage during the occurrences.

The MTM design will not stop the effects of cavitation, but it can protect the pump from damage for a period of time. System problems that lead to these occurrences must still be resolved.

## Pump Designations

### AA, AB

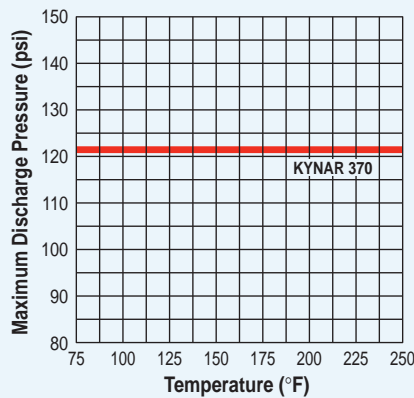

### A50, A60, A70

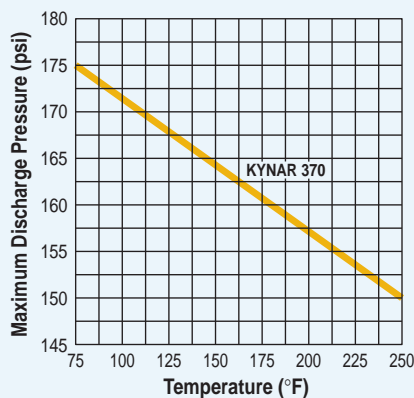

### A30, A40

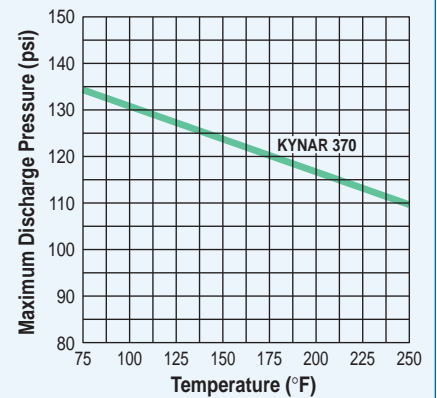

Notes:

- Maximum temperature for all Kynar 370 pumps: 250°F.
- For insulated pumps, multiply "maximum Discharge Pressure" by 0.8.

# S P E C I F I C A T I O N S

## Carbon-Filled Kynar 370 Pump Dimensions

(inches)

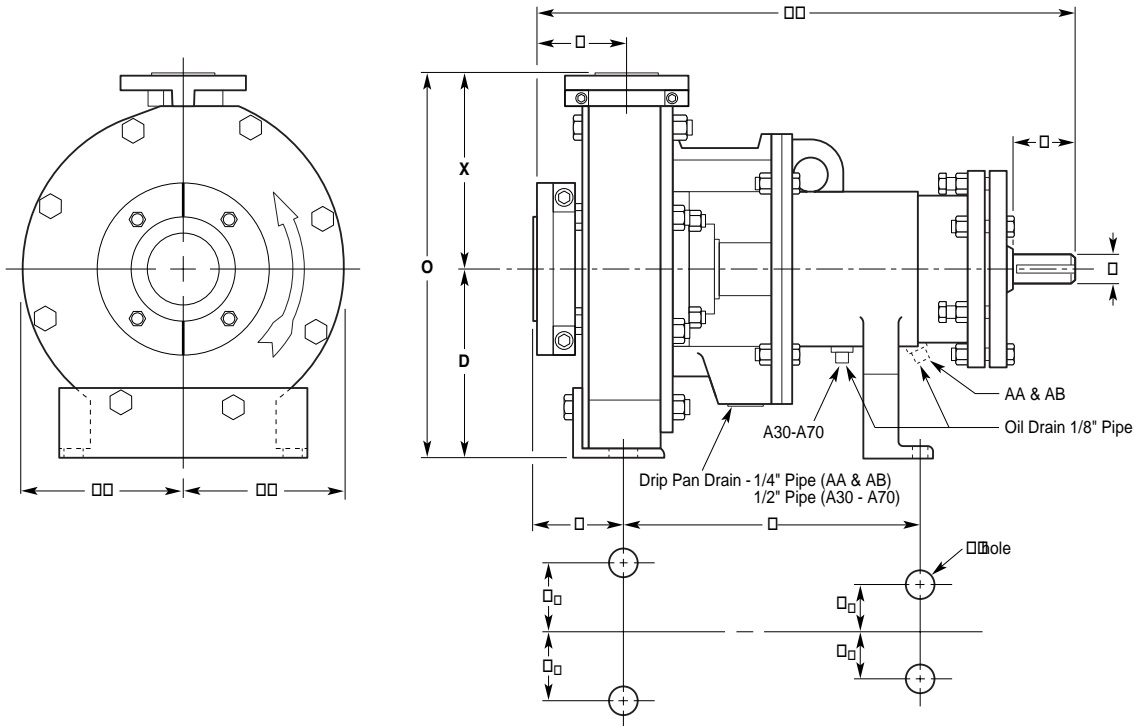

Pump Designation	Pump Size	Weight (lbs)	CP	D	2E <sub>1</sub>	2E <sub>2</sub>	F	H	L	Y	V (min)
PST-AA	1-1/2 x 1 x 6	115	17-1/2	5-1/4	6	0	7-1/4	5/8	4	4	2
PST-AB	3 x 1-1/2 x 6	120	17-1/2	5-1/4	6	0	7-1/4	5/8	4	4	2
PST-A30	3 x 2 x 12	270	23-1/2	10	9-3/4	7-1/4	12-1/2	5/8	4	4	2-5/8
PST-A40	4 x 3 x 12	280	23-1/2	10	9-3/4	7-1/4	12-1/2	5/8	4	4	2-5/8
PST-A50	3 x 1-1/2 x 9	200*	23-1/2	8-1/4	9-3/4	7-1/4	12-1/2	5/8	4	4	2-5/8
PST-A60	3 x 2 x 9	210*	23-1/2	8-1/4	9-3/4	7-1/4	12-1/2	5/8	4	4	2-5/8
PST-A70	4 x 3 x 9	220*	23-1/2	8-1/4	9-3/4	7-1/4	12-1/2	5/8	4	4	2-5/8

\* Weights listed are M versions; add 20 pounds for L versions.

Pump Designation	U Diameter	U Keyway	O	AA	AB	X	F + L	Impeller (max)	Diameter (min)
AA	7/8	3/16 x 3/32	11-3/4	5-1/4	5-1/4	6-1/2	11-1/4	6	4
AB	7/8	3/16 x 3/32	11-3/4	5-1/4	5-1/4	6-1/2	11-1/4	6	4
A30	1-1/8	1/4 x 1/8	21-1/2	9-1/4	9-1/4	11-1/2	16-1/2	12	8
A40	1-1/8	1/4 x 1/8	22-1/2	9-1/2	9-1/2	12-1/2	16-1/2	12	8
A50	1-1/8	1/4 x 1/8	16-3/4	7-1/4	7-1/4	8-1/2	16-1/2	9	6
A60	1-1/8	1/4 x 1/8	17-3/4	7-3/4	7-3/4	9-1/2	16-1/2	9	6
A70	1-1/8	1/4 x 1/8	19-1/4	8	7-1/2	11	16-1/2	9	6

# PUMP ASSEMBLY SPECIFICATIONS

## Pump Overview for Assembly Specifications

*Stan-Cor Series pumps are available with all the accessories needed to create a complete pump system illustrated at right. Use the Pump Overview information on the following pages to help select and size the accessories.*

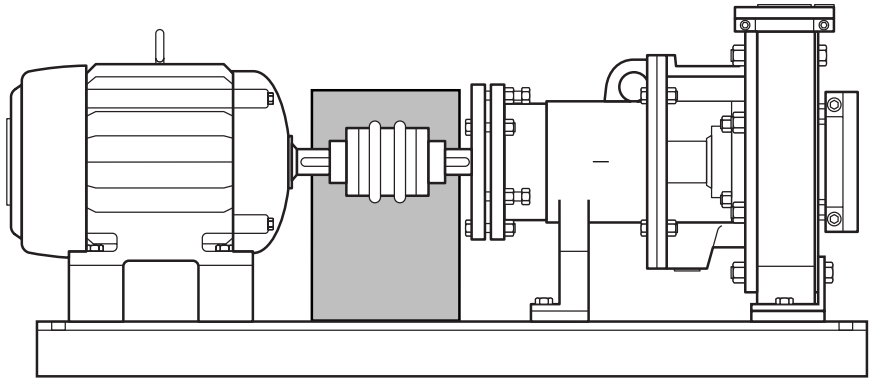

Group	Kynar Models	Shaft Ø @ Seal	Shaft Ø @ Coupling	Pump Center Line
1	PST-AA	1-3/8"	7/8"	5-1/4"
	PST-AB	1-3/8"	7/8"	5-1/4"
2	PST-A50M	1-7/8"	1-1/8"	8-1/4"
	PST-A60M	1-7/8"	1-1/8"	8-1/4"
	PST-A70M	1-7/8"	1-1/8"	8-1/4"
	PST-A30	1-7/8"	1-1/8"	10"
	PST-A40	1-7/8"	1-1/8"	10"
3	PST-A50L	2-1/4"	1-1/8"	8-1/4"
	PST-A60L	2-1/4"	1-1/8"	8-1/4"
	PST-A70L	2-1/4"	1-1/8"	8-1/4"

# SEALED ANSI CENTRIFUGAL PUMPS

## Group 1 Models: PST-AA, PST-AB

(inches)

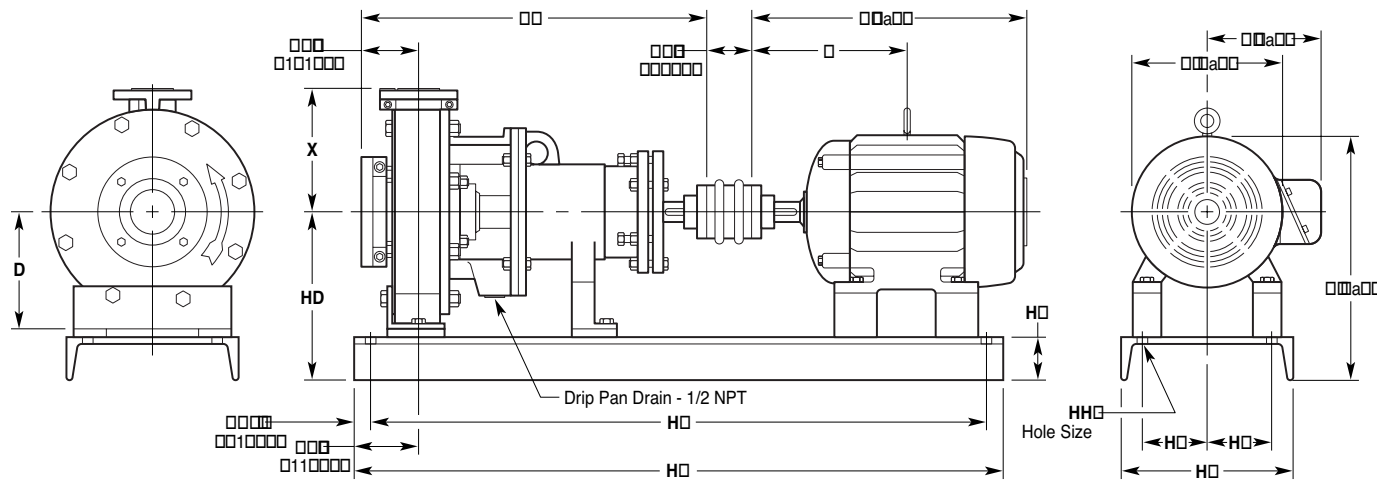

Pump Designation	Pump Size	Discharge Flange*		Suction Flange*		D	X	CP
		Size	Drilling	Size	Drilling			
PST-AA	1-1/2 x 1 x 6	1	4 holes: 1/2-13 UNC on 3-1/8" B.C.	1-1/2	4 holes: 1/2-13 UNC on 3-7/8" B.C.	5-1/4	6-1/2	17-1/2
PST-AB	3 x 1-1/2 x 6	1-1/2	4 holes: 1/2-13 UNC on 3-7/8" B.C.	3	4 holes: 5/8-13 UNC on 6" B.C.	5-1/4	6-1/2	17-1/2

Motor Frame	Base Number	Dimensions (inches)											
		HA	HB	HD	HE	HF	HG	HH	J	K	L	M	N
143T	1T	10	35	8-1/4	4	32-1/2	2-7/8	3/4	12-1/16	6-1/2	7-15/16	7-3/4	12-1/8
145T	1T	10	35	8-1/4	4	32-1/2	2-7/8	3/4	13-1/16	7	7-15/16	7-3/4	12-1/8
182T	1T	10	35	8-1/4	4	32-1/2	2-7/8	3/4	14-9/16	7-3/4	7-1/4	9-3/8	12-15/16
184T	2T	12	39	8-1/2	4-1/2	36-1/2	3-1/8	3/4	15-9/16	8-1/4	7-1/4	9-3/8	13-3/16
213T	2T	12	39	8-1/2	4-1/2	36-1/2	3-1/8	3/4	17-15/16	9-3/8	9-1/8	11-1/8	14-15/16
215T	2T	12	39	8-1/2	4-1/2	36-1/2	3-1/8	3/4	19-7/16	10-3/8	9-1/8	11-1/8	14-15/16

\*Flange drilling is standard 125 lb. cast iron. All flanges are tapped for studs.



# PUMP ASSEMBLY SPECIFICATIONS

**Group 2 Models: PST-A50M, PST-A60M, PST-A70M**

**Group 3 Models: PST-A50L, PST-A60L, PST-A70L**

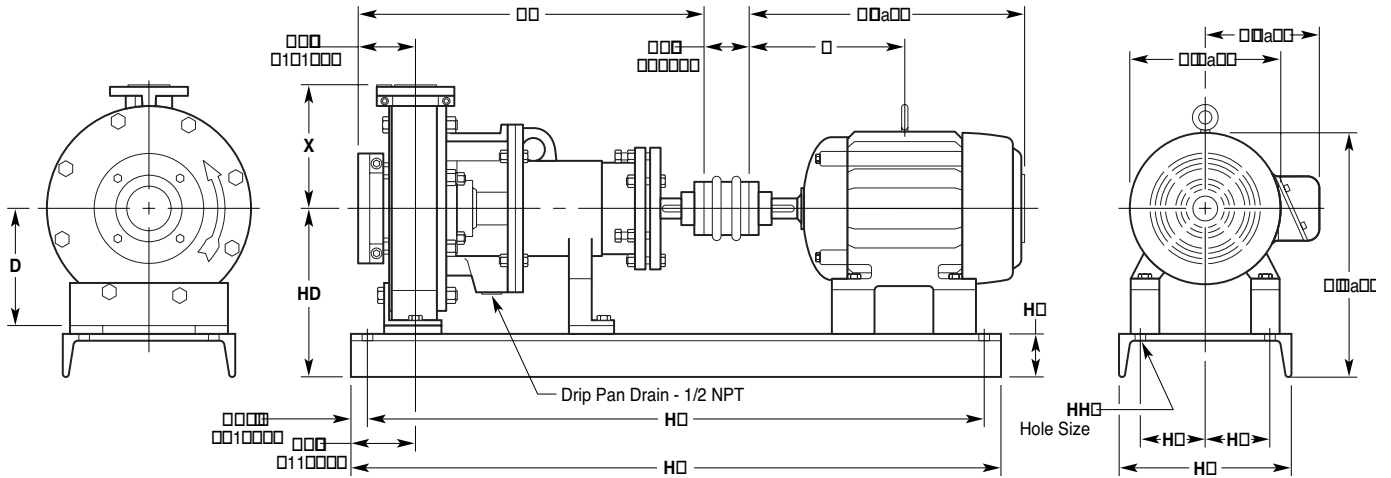

Pump Designation	Pump Size	Discharge Flange*		Suction Flange*		D	X	CP
		Size	Drilling	Size	Drilling			
PST-A50	3 x 1-1/2 x 9	1-1/2	4 holes: 1/2-13 UNC on 3-7/8" B.C.	3	4 holes: 5/8-11 UNC on 6" B.C.	8-1/4	8-1/2	23-1/2
PST-A60	3 x 2 x 9	2	4 holes: 5/8-11 UNC on 4-3/4" B.C.	3	4 holes: 5/8-11 UNC on 6" B.C.	8-1/4	9-1/2	23-1/2
PST-A70	4 x 3 x 9	3	4 holes: 5/8-11 UNC on 6" B.C.	4	8 holes: 5/8-11 UNC on 7-1/2" B.C.	8-1/4	11	23-1/2

Motor Frame	Base Number	Dimensions (inches)												
		HA	HB	HD	HE	HF	HG	HH	J	K	L	M	N	
143T	1	12	45	12	4-1/2	42-1/2	3-1/8	3/4	12-1/16	6-1/2	7-15/16	7-3/4	15-7/8	
145T	1	12	45	12	4-1/2	42-1/2	3-1/8	3/4	13-1/16	7	7-15/16	7-3/4	15-7/8	
182T	1	12	45	12	4-1/2	42-1/2	3-1/8	3/4	14-9/16	7-3/4	7-1/4	9-3/8	16-11/16	
184T	1	12	45	12	4-1/2	42-1/2	3-1/8	3/4	15-9/16	8-1/4	7-1/4	9-3/8	16-11/16	
213T	1	12	45	12	4-1/2	42-1/2	3-1/8	3/4	17-15/16	9-5/8	9-1/8	11-1/8	18-7/16	
215T	1	12	45	12	4-1/2	42-1/2	3-1/8	3/4	19-7/16	10-3/8	9-1/8	11-1/8	18-7/16	
254T	2	15	52	12-3/8	6	49-1/2	3-1/2	3/4	22-13/16	12-3/8	10-3/8	13	18-1/2	
256T	2	15	52	12-3/8	6	49-1/2	3-1/2	3/4	24-1/2	13-1/4	10-3/8	13	18-1/2	
284T	2	15	52	12-3/8	6	49-1/2	3-1/2	3/4	26-5/8	14-1/8	12-5/16	14-1/2	19-13/16	
284TS	2	15	52	12-3/8	6	49-1/2	3-1/2	3/4	25-1/4	12-3/4	12-5/16	14-1/2	19-13/16	
286T	3	18	58	13	7-1/2	55-1/2	4-1/4	1	28-1/8	14-7/8	12-5/16	14-1/2	20-7/16	
286TS	3	18	58	13	7-1/2	55-1/2	4-1/4	1	26-3/4	13-1/2	12-5/16	14-1/2	20-7/16	
324T	3	18	58	13	7-1/2	55-1/2	4-1/4	1	29-5/8	15-3/4	14-7/16	16-7/8	21-13/16	
324TS	3	18	58	13	7-1/2	55-1/2	4-1/4	1	28-1/8	14-1/4	14-7/16	16-7/8	21-13/16	
326T	3	18	58	13	7-1/2	55-1/2	4-1/4	1	31-1/8	16-1/2	14-7/16	16-7/8	21-13/16	
326TS	3	18	58	13	7-1/2	55-1/2	4-1/4	1	29-5/8	15	14-7/16	16-7/8	21-13/16	
364T	3	18	58	14	7-1/2	55-1/2	4-1/4	1	33-7/16	17-3/8	16-1/2	19	23-1/2	
364TS	3	18	58	14	7-1/2	55-1/2	4-1/4	1	31-5/16	15-1/4	16-1/2	19	23-1/2	
365T	3	18	58	14	7-1/2	55-1/2	4-1/4	1	33-7/8	17-7/8	16-1/2	19	23-1/2	
365TS	3	18	58	14	7-1/2	55-1/2	4-1/4	1	31-3/4	15-3/4	16-1/2	19	23-1/2	
404T	4	18	60	15	7-1/2	57-1/2	4-1/4	1	36-7/8	20	17-7/8	22-1/4	24-7/16	
404TS	4	18	60	15	7-1/2	57-1/2	4-1/4	1	33-7/8	17	17-7/8	22-1/4	24-7/16	
405T	4	18	60	15	7-1/2	57-1/2	4-1/4	1	38-3/8	20-3/4	17-7/8	22-1/4	24-7/16	
405TS	4	18	60	15	7-1/2	57-1/2	4-1/4	1	35-3/8	17-3/4	17-11/16	22-1/4	24-7/16	

\*Flange drilling is standard 125 lb. cast iron. All flanges are tapped for studs.

# PUMP ASSEMBLY SPECIFICATIONS

## Group 2 Models: PST-A30, PST-A40

(inches)

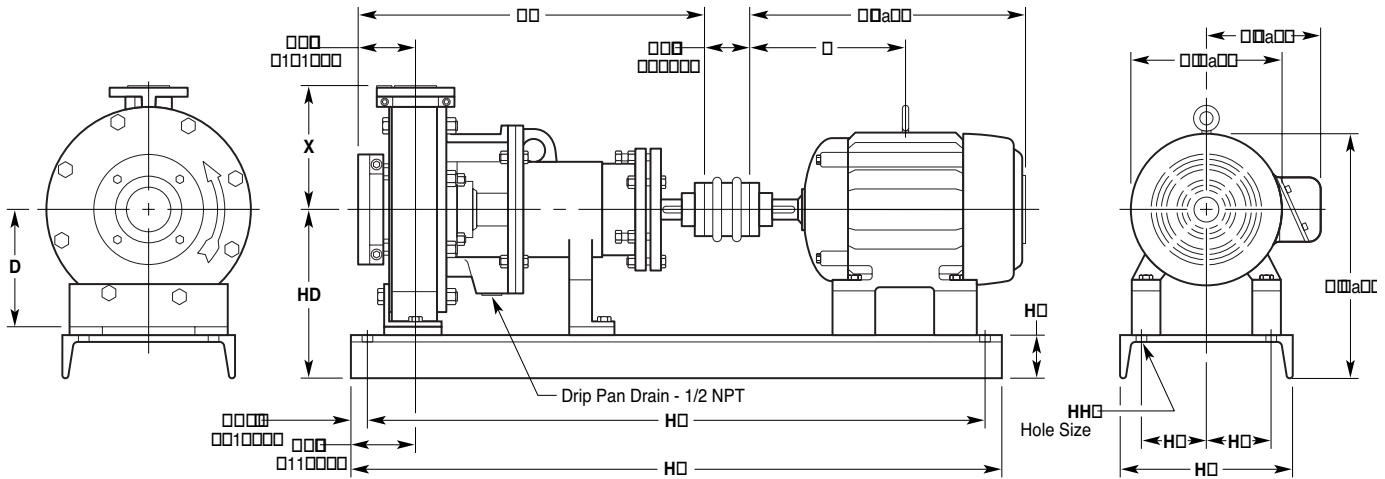

Pump Designation	Pump Size	Discharge Flange*		Suction Flange*		D	X	CP
		Size	Drilling	Size	Drilling			
PST-A30	3 x 2 x 12	2	4 holes: 1/2-13 UNC on 4-3/4" B.C.	3	4 holes: 5/8-11 UNC on 6" B.C.	10	11-1/2	23-1/2
PST-A40	4 x 3 x 12	3	4 holes: 5/8-11 UNC on 6" B.C.	4	8 holes: 5/8-11 UNC on 7-1/2" B.C.	10	12-1/2	23-1/2

Motor Frame	Base Number	Dimensions (inches)											
		HA	HB	HD	HE	HF	HG	HH	J	K	L	M	N
143T	1	12	45	13-3/4	4-1/2	42-1/2	3-1/8	3/4	12-1/16	6-1/2	7-15/16	7-3/4	17-5/8
145T	1	12	45	13-3/4	4-1/2	42-1/2	3-1/8	3/4	13-1/16	7	7-15/16	7-3/4	17-5/8
182T	1	12	45	13-3/4	4-1/2	42-1/2	3-1/8	3/4	14-9/16	7-3/4	7-1/4	9-3/8	18-7/16
184T	1	12	45	13-3/4	4-1/2	42-1/2	3-1/8	3/4	15-9/16	8-1/4	7-1/4	9-3/8	18-7/16
213T	1	12	45	13-3/4	4-1/2	42-1/2	3-1/8	3/4	17-15/16	9-5/8	9-1/8	11-1/8	20-3/16
215T	1	12	45	13-3/4	4-1/2	42-1/2	3-1/8	3/4	19-7/16	10-3/8	9-1/8	11-1/8	20-3/16
254T	2	15	52	14-1/8	6	49-1/2	3-1/2	3/4	22-13/16	12-3/8	10-3/8	13	20-1/4
256T	2	15	52	14-1/8	6	49-1/2	3-1/2	3/4	24-1/2	13-1/4	10-3/8	13	20-1/4
284T	2	15	52	14-1/8	6	49-1/2	3-1/2	3/4	26-5/8	14-1/8	12-5/16	14-1/2	21-9/16
284TS	2	15	52	14-1/8	6	49-1/2	3-1/2	3/4	25-1/4	12-3/4	12-5/16	14-1/2	21-9/16
286T	3	18	58	14-3/4	7-1/2	55-1/2	4-1/4	1	28-1/8	14-7/8	12-5/16	14-1/2	22-3/16
286TS	3	18	58	14-3/4	7-1/2	55-1/2	4-1/4	1	26-3/4	13-1/2	12-5/16	14-1/2	22-3/16
324T	3	18	58	14-3/4	7-1/2	55-1/2	4-1/4	1	29-5/8	15-3/4	14-7/16	16-7/8	23-9/16
324TS	3	18	58	14-3/4	7-1/2	55-1/2	4-1/4	1	28-1/8	14-1/4	14-7/16	16-7/8	23-9/16
326T	3	18	58	14-3/4	7-1/2	55-1/2	4-1/4	1	31-1/8	16-1/2	14-7/16	16-7/8	23-9/16
326TS	3	18	58	14-3/4	7-1/2	55-1/2	4-1/4	1	29-5/8	15	14-7/16	16-7/8	23-9/16
364T	3	18	58	14-3/4	7-1/2	55-1/2	4-1/4	1	33-7/16	17-3/8	16-1/2	19	24-1/4
364TS	3	18	58	14-3/4	7-1/2	55-1/2	4-1/4	1	31-5/16	15-1/4	16-1/2	19	24-1/4
365T	3	18	58	14-3/4	7-1/2	55-1/2	4-1/4	1	33-7/8	17-7/8	16-1/2	19	24-1/4
365TS	3	18	58	14-3/4	7-1/2	57-1/2	4-1/4	1	31-3/4	15-3/4	16-1/2	19	24-1/4

\*Flange drilling is standard 125 lb. cast iron. All flanges are tapped for studs.

## STAN-COR



Stan-Cor ANSI centrifugal pumps provide exclusive design advantages over all other centrifugal pumps. For applications requiring durability and performance on dirty, difficult fluids, Stan-Cor pumps are the most cost-effective solution.

- Solid Kynar designed for handling abrasive, dirty process fluids
- Total dynamic head to 350 feet
- Flow rates to 700 gpm

# OTHER WANNER PUMP TECHNOLOGY SOLUTIONS

## *Hydra-Cell*<sup>®</sup> Seal-less Pumps

### **Seal-less, Positive Displacement Pumps**

[www.Hydra-Cell.com](http://www.Hydra-Cell.com)

- Handles the full spectrum of difficult fluids for industrial pumping applications
- Pressures to 2,500 psi (172 bar)
- Flow rates to 37 gpm (140 l/min)

### **Seal-less, High-horsepower Pumps**

[www.Hydra-Cell.com](http://www.Hydra-Cell.com)

- Seal-less design provides full containment of the pumping chamber
- Pressures to 5000 psi (345 bar)
- Flow rates to 96 gpm (366.1 l/min)



## *Hydra-Cell*<sup>®</sup> METERING SOLUTIONS™

### **Seal-less Metering Pumps**

[www.Hydra-Cell.com/metering](http://www.Hydra-Cell.com/metering)

- Designed for clear water to thick slurry metering applications
- Meets or exceeds API 675 performance standards with virtually pulse-free flow



## **VECTOR**

### **Peristaltic Pumps**

[www.VectorPump.com](http://www.VectorPump.com)

- High-viscosity fluids
- Aggressive and corrosive fluids
- High-purity solutions
- Abrasive fluids



## **Wanner Engineering, Inc.**

1204 Chestnut Avenue  
Minneapolis, MN 55403 USA  
Phone: 612-332-5861  
Fax: 612-332-6937  
Toll-Free Fax (USA): 800-332-6812  
Email: [sales@wannereng.com](mailto:sales@wannereng.com)  
[www.WannerEng.com](http://www.WannerEng.com)

## **Wanner International Ltd.**

8 & 9, Fleet Business Park  
Sandy Lane, Church Crookham,  
Hampshire GU52 8BF England  
Phone: + (44) 01252 816847  
Fax: + (44) 01252 629242  
Email: [sales@wannerint.com](mailto:sales@wannerint.com)  
[www.WannerInt.com](http://www.WannerInt.com)