

Part Number/Price

Part #	Capacity	Platform Dimensions	Column Height	Est. Weight	Price
115 VAC					
105957†	5 lb x 0.001 lb (2.5 kg x 0.0005 kg) or (80 oz x 0.02 oz)	10 x 10 x 4.25 in	12 in	29 lb	\$1,415.00
105958†	10 lb x 0.002 lb (5 kg x 0.001 kg) or (160 oz x 0.05 oz)	10 x 10 x 4.25 in	12 in	29 lb	\$1,415.00
105959†	25 lb x 0.005 lb (10 kg x 0.002 kg) or (400 oz x 0.1 oz)	10 x 10 x 4.25 in	12 in	29 lb	\$1,415.00
105960†	25 lb x 0.005 lb (10 kg x 0.002 kg) or (400 oz x 0.1 oz)	12 x 12 x 4.25 in	12 in	33 lb	\$1,495.00
105961†	50 lb x 0.01 lb (25 kg x 0.005 kg) or (800 oz x 0.2 oz)	12 x 12 x 4.25 in	12 in	33 lb	\$1,495.00
105962†	100 lb x 0.02 lb (50 kg x 0.01 kg) or (1,600 oz x 0.5 oz)	12 x 12 x 4.25 in	12 in	33 lb	\$1,495.00
230 VAC CE marked/OIML approved					
106123††	3 kg x 0.001 kg	254 x 254 x 108 mm	305 mm	13.2 kg	\$1,415.00
106124††	6 kg x 0.002 kg	254 x 254 x 108 mm	305 mm	13.2 kg	\$1,415.00
106125††	15 kg x 0.005 kg	254 x 254 x 108 mm	305 mm	13.2 kg	\$1,415.00
106126††	15 kg x 0.005 kg	305 x 305 x 108 mm	305 mm	15 kg	\$1,495.00
106127††	30 kg x 0.01 kg	305 x 305 x 108 mm	305 mm	15 kg	\$1,495.00
106128††	60 kg x 0.02 kg	305 x 305 x 108 mm	305 mm	15 kg	\$1,495.00
230 VAC					
118891†	2.5 kg x 0.0005 kg (5 lb x 0.001 lb) or (80 oz x 0.02 oz)	10 x 10 x 4.25 in	12 in	29 lb	\$1,415.00
118892†	5 kg x 0.001 kg (10 lb x 0.002 lb) or (160 oz x 0.05 oz)	10 x 10 x 4.25 in	12 in	29 lb	\$1,415.00
118893†	10 kg x 0.002 kg (25 lb x 0.005 lb) or (400 oz x 0.1 oz)	10 x 10 x 4.25 in	12 in	29 lb	\$1,415.00
118895†	10 kg x 0.002 kg (25 lb x 0.005 lb) or (400 oz x 0.1 oz)	12 x 12 x 4.25 in	12 in	33 lb	\$1,495.00
118896†	25 kg x 0.005 kg (50 lb x 0.01 lb) or (800 oz x 0.2 oz)	12 x 12 x 4.25 in	12 in	33 lb	\$1,495.00
118897†	50 kg x 0.01 kg (100 lb x 0.02 lb) or (1,600 oz x 0.5 oz)	12 x 12 x 4.25 in	12 in	33 lb	\$1,495.00



† NEMA 5-15 plug



†† CEE 7/7 plug

Options/Accessories

Part #	Description	Price
200578	Ethernet TCP/IP	\$400.00
108671	Wireless LAN card Wi-Fi 802.11 A/B	\$570.00
200577	USB Port (PC connection only) cable included	\$175.00
95357	USB cable, Type A to mini-B, 1 m	\$10.00
171968	Firmware download cable	\$35.00
96736	Fiber optic board	\$250.00
78026	Fiber optic, duplex cable 100 ft	\$140.00
80892	Fiber optic cutter	\$9.00
117358	WeighVault™ (requires part number 77142 or 108671)	\$250.00

* To convert inches to millimeters: Multiply inch measurement by 25.4

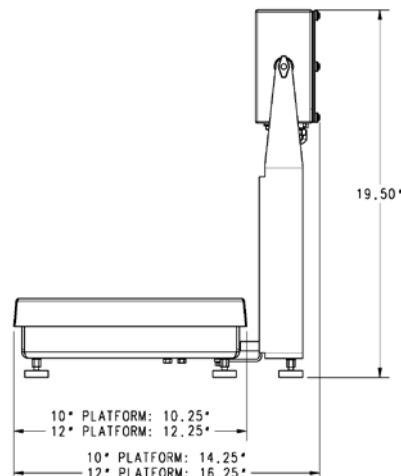
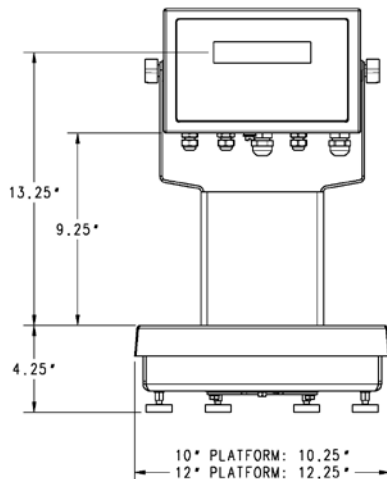

CW-90X

Over/Under Washdown Checkweigher



Standard Features

- Piezo keypad consisting of ZERO, UNITS, PRINT, TARE, OVER, UNDER, ID, TARGET, ENTER, MENU, POWER
- 304 stainless steel, IP69K rated indicator
- PreVent™ breather vent
- Storage for up to 50 IDs
- Unit of measure: kg, gm, lb, oz, lb/oz (lb/oz is not Legal for Trade)
- High-intensity LED display
- Battery backed time and date
- Two full-duplex RS-232 serial ports
- Configurable print formats
- Audit trail tracking
- Optional communications: Ethernet, USB or fiber-optic
- Four configurable Digital I/O
- Reflash memory to upgrade firmware
- Auto print capability
- Accumulator
- Factory Calibrated

Scale Base:

- IP69K, stainless steel, hermetically sealed load cell
- 304 stainless steel
- Meets HACCP requirements
- Five point overload protection



Approvals



Specifications

Power-AC:

Line voltages:
115/230 VAC
Frequency:
50/60 Hz
Fused at 2.5A

Power Consumption:

1.5 A at 115 VAC (8 W),
0.75 A at 230 VAC (8 W)

Excitation Voltage:

+5VDC 8 x 350 Ω or 16 x 700 Ω load cells

Analog Signal Input Range:

-0.5 mV/V + 4.5 mV/V

Analog Signal Sensitivity:

0.3 μV/graduation minimum, 1.5 μV/graduation recommended

Measurement Rate:

960, 480, 240, 120, 60, 30, 15, 7.5 per second

System Linearity:

±0.01% full scale

Digital I/O:

Four channels on CPU board

Circuit Protection:

RFI, EMI, EFT, ESD and surge protection

Display:

Large 0.8 in, 14-segment, six-digit high-intensity red LED display

Status Annunciators:

Designators for %, kg, gm, lb, oz, center of zero, Gross/Brutto, N, T, PT, neg, motion

Operating Temperature:

Legal: 14° F to 104° F (-10° C to 40° C)

Rating/Material:

IP69K, stainless steel

Display Resolution:

100,000 graduations maximum

Load Cell:

IP69K, stainless steel, hermetically sealed

Warranty:

Three-year limited warranty

Approvals:

Indicator:

NTEP CC 08-092, Class III/IIIL 10,000 d
Measurement Canada AM-5710, Class III 10,000 d
OIML R76/2006-GBI-10.02
TC11569
T10807

UL and CUL listed
CE marked

Scale:

NTEP CC 95-072, Class III 5,000 d
Measurement Canada AM-5082, Class III 5,000 d
NSF