



Shown with optional insert



PN 87982



PN 11534



PN 158121



PN 156989



PN 156285



PN 156284



Polycarbonate Cases



PN 21230



PN 11531



PN 11572



PN 69429



PN 69229

Pelican Cases

Part #	Width	Length	Closed Height	Max Load	Price
21230	22 in	17 in	8 in	45 lb	\$360.00
21229	17 in	11 3/4 in	6 in	50 lb	\$242.00

Replacement Cases

Part #	Width	Length	Closed Height	Max Load	Price
Acrylic Clean Room Cases					
89180	8.7 in	4.7 in	2.8 in		\$196.00
89179	6.04 in	3.04 in	1.8 in		\$105.00
89181	12 in	5 1/4 in	4 in		\$310.00
89182	13 1/4 in	8 1/2 in	5 3/4 in		\$490.00
Leatherette					
69429	3 3/4 in	1 7/8 in	1 1/16 in	3 lb	\$32.00
69229	3 7/16 in	2 1/2 in	7/8 in	1 lb	\$32.00
Polycarbonate Cases					
Consult	4.25 in	4.25 in	4.875 in		\$32.00
Consult	3.12 in	3.12 in	3.61 in		\$32.00
Consult	2.25 in	2.25 in	2.45 in		\$35.00
Plastic					
87982	12 in	8 in	3 1/2 in	5 lb	\$70.00
ABS Plastic					
11531	13 1/2 in	7 5/8 in	6 in	40 lb	\$211.00
11534	14 3/8 in	9 3/8 in	7 5/8 in	55 lb	\$222.00
11572	8 3/8 in	6 1/2 in	7 1/8 in	25 lb	\$160.00
Sealers Cube Wt - with precut foam insert					
40783	14 3/8 in	9 3/8 in	7 5/8 in		\$305.00
Heavy Duty Industrial Cases					
156989	16.3 in	22.4 in	10.5 in	95 lb	\$725.00
156285	11.4 in	16.4 in	9.0 in	55 lb	\$485.00
158121	9.5 in	12.63 in	4.75 in	20 lb	\$278.00
156284	9.9 in	9.9 in	11.0 in	60 lb	\$390.00
Protection Containers					
80420	Capsule				\$4.00
50038	Vial				\$4.00

IQ Plus® 2100

Digital Bench Scale



IQ plus 2100 with attachment bracket



IQ plus 2100 with column



IQ plus 2100 with tilt stand

Specifications

Power-AC:

Line Voltages:
115 or 230 VAC

Frequency:

50 or 60 Hz

Power Consumption:

70 mA at 115 VAC (8 W)
35 mA at 230 VAC (8 W)

Display Resolution:

10,000 graduations maximum

Digital Inputs:

Two inputs, TTL or switch closure, active-low

Serial Communications:

Full-duplex RS-232; 9600, 4800, 2400, 1200 bps;
seven or eight data bits; even, odd or no parity

Display:

Six-digit light-emitting diode (LED) display
Seven-segment, 0.8 in (20 mm) digits

LED Annunciators:

Negative value, center of zero, motion, kg, g, lb, oz

Keypad:

Two stainless steel piezo switches

Operating Temperature:

14° F to 104° F (-10° C to 40° C)

Rating/Material:

NEMA Type 4X/IP66, stainless steel

Load Cell:

Aluminum, environmentally sealed

Warranty:

Two-year limited warranty

Approvals:

Indicator:

NTEP CC 00-045 Class III/IIIL 10,000 d
Measurement Canada AM-5374;
UL and C-UL listed

Base:

NTEP CC 95-072, Class III 5,000 d

Standard Features

- NEMA Type 4X/IP66
- 304 stainless steel construction
- Large, bold 0.8 in light emitting diode (LED) display
- Status annunciators: lb, kg, oz, g, negative, motion, center of zero
- One full-duplex RS-232 port
- Two digital inputs for remote zero, print and units
- 12 in column, attachment bracket or tilt stand for table, wall or under counter mounting
- Aluminum, single-point load cell
- Overload and upload stops on scale base
- Stainless steel, non-tactile feel, piezo zero and units buttons
- Unit of measure: kg, gm, lb, oz, lb/oz (lb/oz is not Legal for Trade)
- PreVent™ breather vent
- Factory Calibrated

Approvals



Dimensions

Platform Dimensions	L	L1
10 x 10 in (254 x 254 mm)	10.25 in (260.4 mm)	10 in (254 mm)
12 x 12 in (304.8 x 304.8 mm)	12.25 in (311.2 mm)	12 in (304.8 mm)

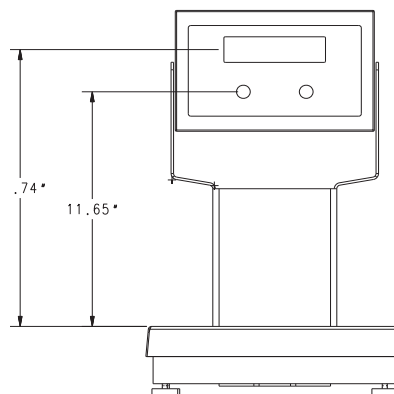
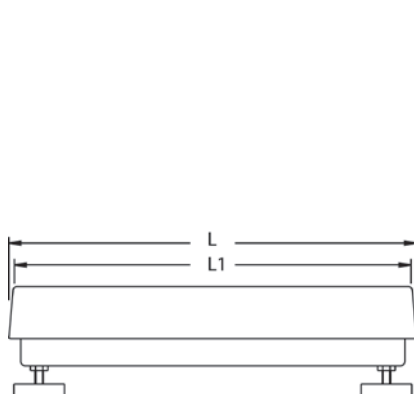

With 12 in column

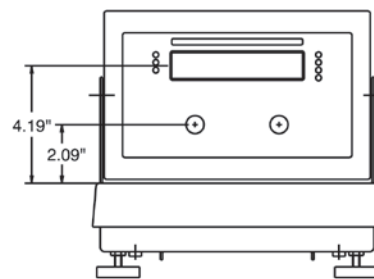

With attachment bracket