



INDUSTRIAL DIRECT DRIVE 20

Steam Heated Air Curtain

Data Sheet

For Mounting Heights To 20' (environmental separation)

STANDARD CONSTRUCTION

- Single speed T.E.A.O. motor(s) - direct drive
- Gray powder coated exterior (Optional: Custom Color or Stainless)
- Split cabinet construction for fan assembly removal
- Top Mounting only
- Front air intake (Optional: top)
- High efficiency Pro-V Nozzle

- Coil Features:
 - Galvanized steel casing
 - 5/8" copper tube with .035" wall
 - Aluminum fins
 - Leak tested at 450 psi

2 Year
Limited
Warranty



MODEL	Nozzle Width (in)	Max Vel. at Nozzle (fpm)	Avg. Outlet Vel. (fpm)	Air Volume (cfm)	Outlet Vel. Uniformity	Power Rating (kW)	Motor(s) @ hp	Coil Output (MBH)	Inlet Pressure (PSIG)	Condensate (lbs/hr)	Air Temp. Rise (°F)	Net Wt. (lbs)
IDC20-1060S	60.00	6,580	3,870	6,854	89%	4.70	1 @ 5	279.4	5	288.0	38°	464
IDC20-1072S	72.00	6,549	3,852	8,186	89%	4.90	1 @ 5	364.7	5	344.8	38°	518
IDC20-1084S	84.00	6,076	3,574	8,861	87%	4.90	1 @ 5	409.8	5	387.6	39°	572
IDC20-1096S	96.00	6,900	4,059	11,500	92%	6.80	1 @ 7½	498.9	5	471.7	37°	701
IDC20-1108S	108.00	6,747	3,969	12,650	90%	6.90	1 @ 7½	555.1	5	524.8	37°	791
IDC20-1120S	117.00	7,494	4,523	15,612	88%	8.70	1 @ 10	640.6	5	605.4	35°	867
IDC20-1132S	132.00	7,017	4,127	16,080	87%	8.90	1 @ 10	691.7	5	653.8	36°	926
IDC20-1144S	144.00	7,640	4,381	19,100	87%	11.70	1 @ 15	786.2	5	742.9	35°	975
IDC20-1156S	156.00	7,405	4,356	20,055	86%	11.90	1 @ 15	839.0	5	793.0	35°	1,089
IDC20-1168S	168.00	7,783	4,323	22,700	90%	12.80	1 @ 15	925.3	5	874.4	34°	1,183
IDC20-1180S	180.00	7,300	4,294	22,814	91%	12.90	1 @ 15	961.5	5	908.8	36°	1,240
IDC20-2192S	192.00	6,900	4,059	23,000	92%	13.60	2 @ 7½	997.9	5	943.3	37°	1,369

NOTES:

1. Operation at 50 Hz will generate approximately a 17% reduction in performance.
2. Performance data based on AMCA licensed data from unheated units.
3. Coil performance based on 65°F entering air temperature.
4. Standard connection same end supply/return (Optional: opposite end supply/return).
5. Coil should be field supplied with a solenoid valve that energizes only when air curtain is energized. Consideration must be taken for freeze protection when necessary.
6. Maximum leaving air temperature shall not exceed 120°F.
7. Consult factory for alternate steam pressures, opposite end supply/return connections performance data, or vertically mounted units.

See sheet EP-444 for amp draws/total load requirements.

MODEL NUMBER CONFIGURATION

IDC20-1 060 S D-F-SS

Series	# of Motors	Opening Width	Heat	Voltage	Intake	Opt. Cabinet Finish
IDC20	1, 2	060" - 192"	S=Steam Heated	D=208/3/60 E=240/3/60 H=480/3/60 I=600/3/60 T=380/3/50	T=Top F=Front	SS=Stainless Steel CC=Custom Color

Sound level measured 10' (3m) from the unit in free field:
5, 7½, 10, 15 & (7½ + 7½) hp motor(s):
73 dBA, 75 dBA, 76 dBA, 78 dBA & 78 dBA

Berner reserves the right to alter specifications without prior notice.



INDUSTRIAL DIRECT DRIVE 20

Steam Heated Air Curtain

Electrical Performance Sheet

		208/3/60 (voltage code D) TOTAL MOTOR AMP DRAW			240/3/60 (voltage code E) TOTAL MOTOR AMP DRAW			480/3/60 (voltage code H) TOTAL MOTOR AMP DRAW		
MODEL	Qty @ HP	# CKTS	AMPS PER CIRCUIT	BREAKER RATING PER CIRCUIT	# CKTS	AMPS PER CIRCUIT	BREAKER RATING PER CIRCUIT	# CKTS	AMPS PER CIRCUIT	BREAKER RATING PER CIRCUIT
IDC20-1060S IDC20-1072S IDC20-1084S	1 @ 5	1	17.0	35	1	15.8	35	1	7.9	20
IDC20-1096S IDC20-1108S	1 @ 7.5	1	23.0	50	1	22.0	45	1	11.0	25
IDC20-1120S IDC20-1132S	1 @ 10	1	31.5	60	1	30.6	60	1	15.3	30
IDC20-1144S IDC20-1156S IDC20-1168S IDC20-1180S	1 @ 15	1	46.0	100	1	44.0	100	1	22.0	45
IDC20-2192S	2 @ 7.5	1	46.0	70	1	44.0	70	1	22.0	35

		600/3/60 (voltage code I) TOTAL MOTOR AMP DRAW			380/3/50 (voltage code T) TOTAL MOTOR AMP DRAW		
MODEL	Qty @ HP	# CKTS	AMPS PER CIRCUIT	BREAKER RATING PER CIRCUIT	# CKTS	AMPS PER CIRCUIT	BREAKER RATING PER CIRCUIT
IDC20-1060S IDC20-1072S IDC20-1084S	1 @ 5	1	6.3	15	1	7.7	20
IDC20-1096S IDC20-1108S	1 @ 7.5	1	8.5	20	1	9.0	20
IDC20-1120S IDC20-1132S	1 @ 10	1	11.7	25	1	12.5	25
IDC20-1144S IDC20-1156S IDC20-1168S IDC20-1180S	1 @ 15	1	17.5	35	1	18.0	40
IDC20-2192S	2 @ 7.5	1	17.0	30	1	18.0	30

Berner reserves the right to alter specifications without prior notice.

www.berner.com Berner International 800.245-4455
111 Progress Ave. / New Castle / PA / 16101 / USA

EP-444
December, 2018

IDC20 STEAM HEATED TOP INTAKE SAME END SUP./RET.

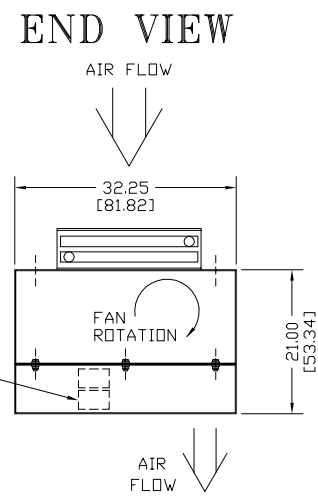
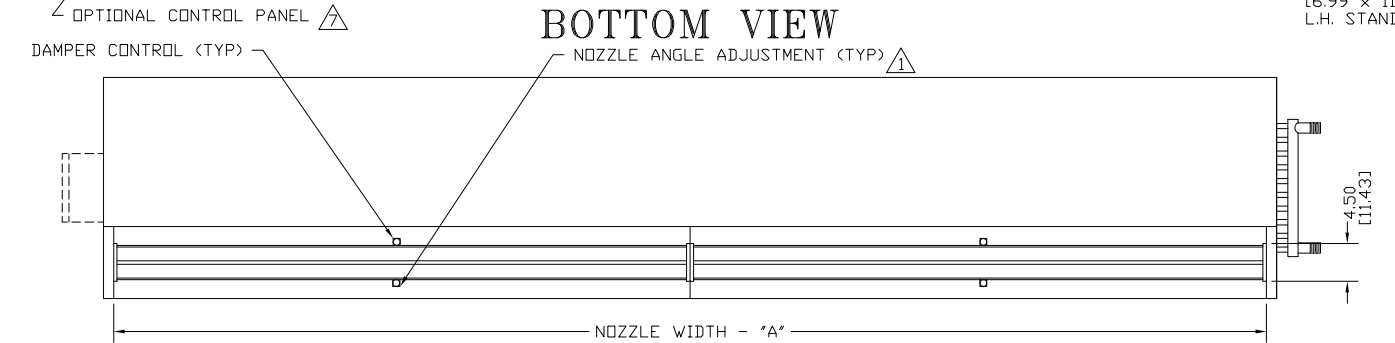
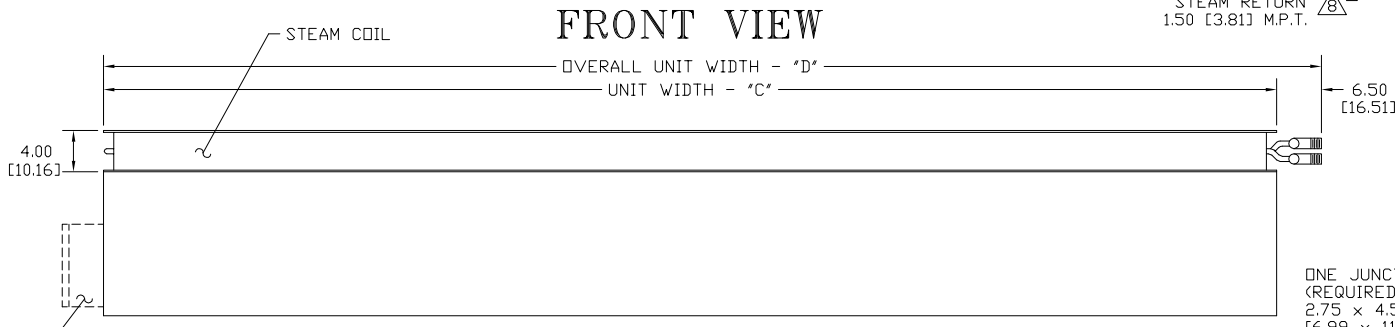
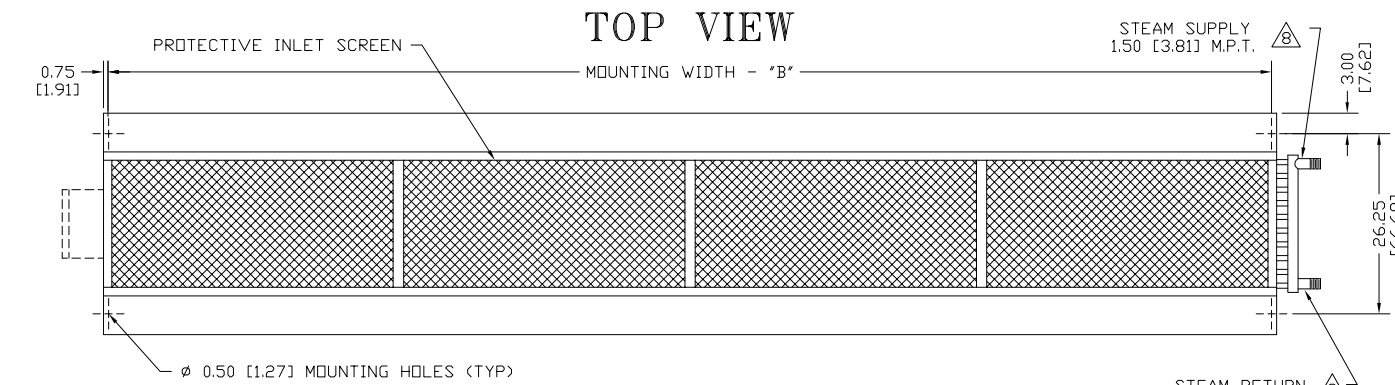

ONE JUNCTION BOX PER MOTOR
(REQUIRED FOR REMOTE PANEL)
2.75 x 4.50 x 2.00
[6.99 x 11.43 x 5.08]
L.H. STANDARD, R.H. OPTIONAL

NOTES:

- 1 AIR CURTAIN MUST BE INSTALLED SO AIR STREAM IS NOT OBSTRUCTED WHEN DEFLECTED 20° TO EITHER SIDE OF C.
- 2 ELECTRICAL CONNECTIONS TO BE FLEXIBLE.
- 3 FIELD VERIFY DIMENSIONS.
- 4 ANCHORS TO SUPPORTING STRUCTURE BY OTHERS.
- 5 ADEQUACY OF SUPPORTING STRUCTURE IS TO BE VERIFIED BY A PROFESSIONAL STRUCTURAL ENGINEER.
- 6 LETTER "S" IN MODEL NUMBER DESIGNATES, STEAM HEATED UNIT. THE "T" DESIGNATES TOP INTAKE.
- 7 OPTIONAL CONTROL PANEL AVAILABLE: LEFT HAND MOUNT, RIGHT HAND MOUNT, OR REMOTE. PLEASE SPECIFY.
- 8 COIL CONNECTIONS AS SHOWN, OPPOSITE AND SAME END CONNECTIONS AVAILABLE, PLEASE SPECIFY.
- 9 DIMENSIONS IN INCHES [CENTIMETERS].

MODEL	NOZZLE WIDTH "A"	MOUNTING WIDTH "B"	UNIT WIDTH "C"	OVERALL WIDTH "D"
IDC20-1060S-T	60.00 [152.40]	61.50 [156.21]	63.00 [160.02]	69.50 [176.53]
IDC20-1072S-T	72.00 [182.88]	73.50 [186.69]	75.00 [190.50]	81.50 [207.01]
IDC20-1084S-T	84.00 [213.36]	85.50 [217.17]	87.00 [220.98]	93.50 [237.49]
IDC20-1096S-T	96.00 [243.84]	97.50 [247.65]	99.00 [251.46]	105.50 [267.97]
IDC20-1108S-T	108.00 [274.32]	109.50 [278.13]	111.00 [281.94]	117.50 [298.45]
IDC20-1120S-T	117.00 [297.18]	118.50 [300.99]	120.00 [304.80]	126.50 [321.31]
IDC20-1132S-T	132.00 [335.28]	133.50 [339.09]	135.00 [342.90]	141.50 [359.41]
IDC20-1144S-T	144.00 [365.76]	145.50 [369.57]	147.00 [373.38]	153.50 [389.89]
IDC20-1156S-T	156.00 [396.24]	157.50 [400.05]	159.00 [403.86]	165.50 [420.37]
IDC20-1168S-T	168.00 [426.72]	169.50 [430.53]	171.00 [434.34]	177.50 [450.85]
IDC20-1180S-T	180.00 [457.20]	181.50 [461.01]	183.00 [464.82]	189.50 [481.33]
IDC20-2192S-T	192.00 [487.68]	193.50 [491.49]	195.00 [495.30]	201.50 [511.81]

PROJECT		
LOCATION		
ARCHITECT		
ENGINEER		
DWG. NO.	IDC20-STM1	TITLE: BERNER
DATE	09JUNE14	MODEL IDC20 AIR CURTAIN
BY	S. Beil	TOP INTAKE - STEAM HEATED SYSTEM
REPLACES	-	
BY	-	BERNER INTERNATIONAL CORP. NEW CASTLE, PA.

IDC20 STEAM HEATED TOP INTAKE OPP. END SUP./RET.

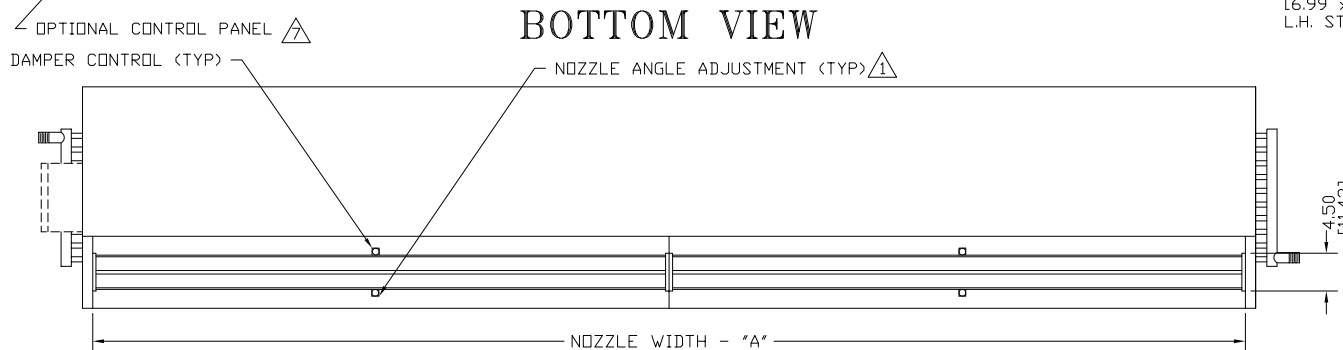
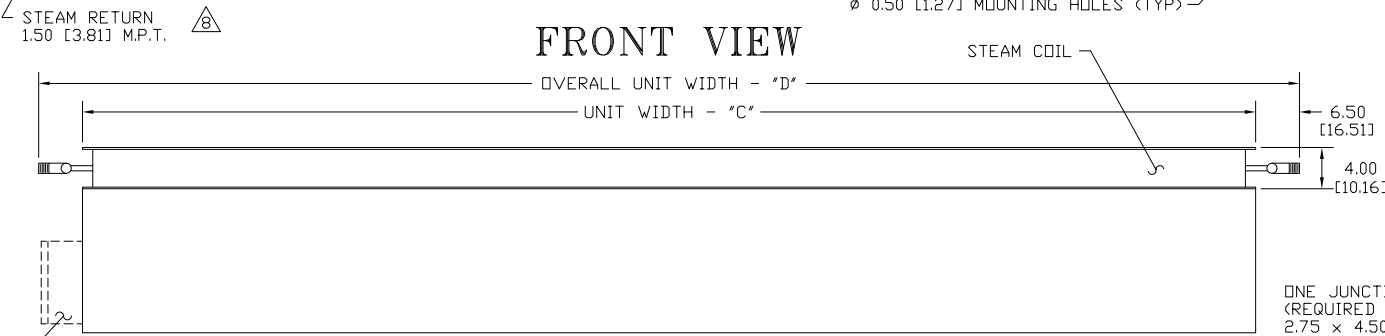
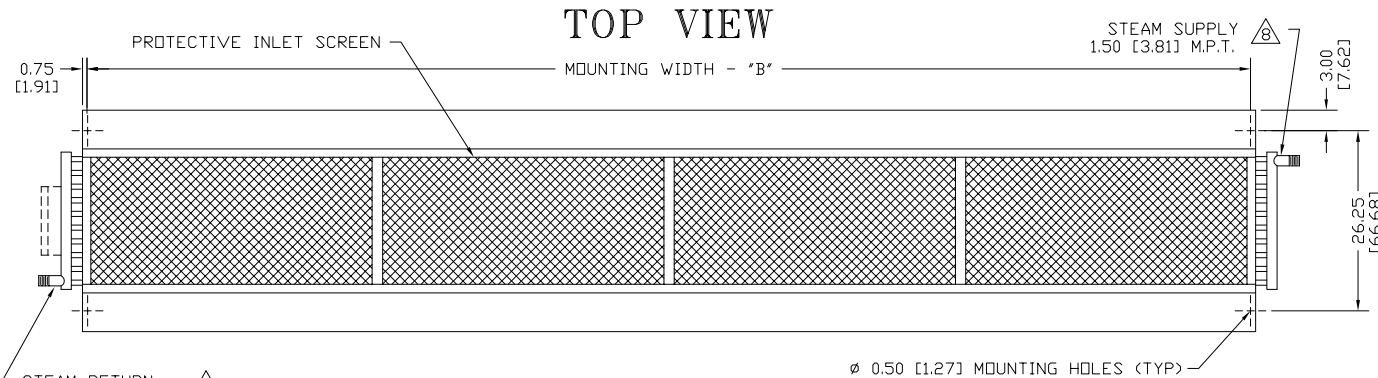

END VIEW

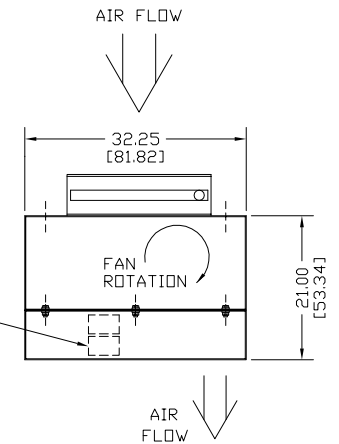

ONE JUNCTION BOX PER MOTOR
(REQUIRED FOR REMOTE PANEL)
2.75 x 4.50 x 2.00
[6.99 x 11.43 x 5.08]
L.H. STANDARD; R.H. OPTIONAL

NOTES:

- 1 AIR CURTAIN MUST BE INSTALLED SO AIR STREAM IS NOT OBSTRUCTED WHEN DEFLECTED 20° TO EITHER SIDE OF C.
- 2 ELECTRICAL CONNECTIONS TO BE FLEXIBLE.
- 3 FIELD VERIFY DIMENSIONS.
- 4 ANCHORS TO SUPPORTING STRUCTURE BY OTHERS.
- 5 ADEQUACY OF SUPPORTING STRUCTURE IS TO BE VERIFIED BY A PROFESSIONAL STRUCTURAL ENGINEER.
- 6 LETTER "S" IN MODEL NUMBER DESIGNATES, STEAM HEATED UNIT. THE "T" DESIGNATES TOP INTAKE.
- 7 OPTIONAL CONTROL PANEL AVAILABLE: LEFT HAND MOUNT, RIGHT HAND MOUNT, OR REMOTE. PLEASE SPECIFY.
- 8 COIL CONNECTIONS AS SHOWN, OPPOSITE AND SAME END CONNECTIONS AVAILABLE, PLEASE SPECIFY.
- 9 DIMENSIONS IN INCHES [CENTIMETERS].

MODEL	NOZZLE WIDTH "A"	MOUNTING WIDTH "B"	UNIT WIDTH "C"	OVERALL WIDTH "D"
IDC20-1060S-T	60.00 [152.40]	61.50 [156.21]	63.00 [160.02]	76.00 [193.04]
IDC20-1072S-T	72.00 [182.88]	73.50 [186.69]	75.00 [190.50]	88.00 [223.52]
IDC20-1084S-T	84.00 [213.36]	85.50 [217.17]	87.00 [220.98]	100.00 [254.00]
IDC20-1096S-T	96.00 [243.84]	97.50 [247.65]	99.00 [251.46]	112.00 [284.48]
IDC20-1108S-T	108.00 [274.32]	109.50 [278.13]	111.00 [281.94]	124.00 [314.96]
IDC20-1120S-T	117.00 [297.18]	118.50 [300.99]	120.00 [304.80]	133.00 [337.82]
IDC20-1132S-T	132.00 [335.28]	133.50 [339.09]	135.00 [342.90]	148.00 [375.92]
IDC20-1144S-T	144.00 [365.76]	145.50 [369.57]	147.00 [373.38]	160.00 [406.40]
IDC20-1156S-T	156.00 [396.24]	157.50 [400.05]	159.00 [403.86]	172.00 [436.88]
IDC20-1168S-T	168.00 [426.72]	169.50 [430.53]	171.00 [434.34]	184.00 [467.36]
IDC20-1180S-T	180.00 [457.20]	181.50 [461.01]	183.00 [464.82]	196.00 [497.84]
IDC20-2192S-T	192.00 [487.68]	193.50 [491.49]	195.00 [495.30]	208.00 [528.32]

PROJECT		TITLE: BERNER
LOCATION		MODEL IDC20 AIR CURTAIN
ARCHITECT		TOP INTAKE - STEAM HEATED SYSTEM
ENGINEER		
DWG. NO.	IDC20-STM2	
DATE	09JUNE14	
BY	S. Beil	
REPLACES	-	
BY	-	BERNER INTERNATIONAL CORP. NEW CASTLE, PA.

TOP VIEW

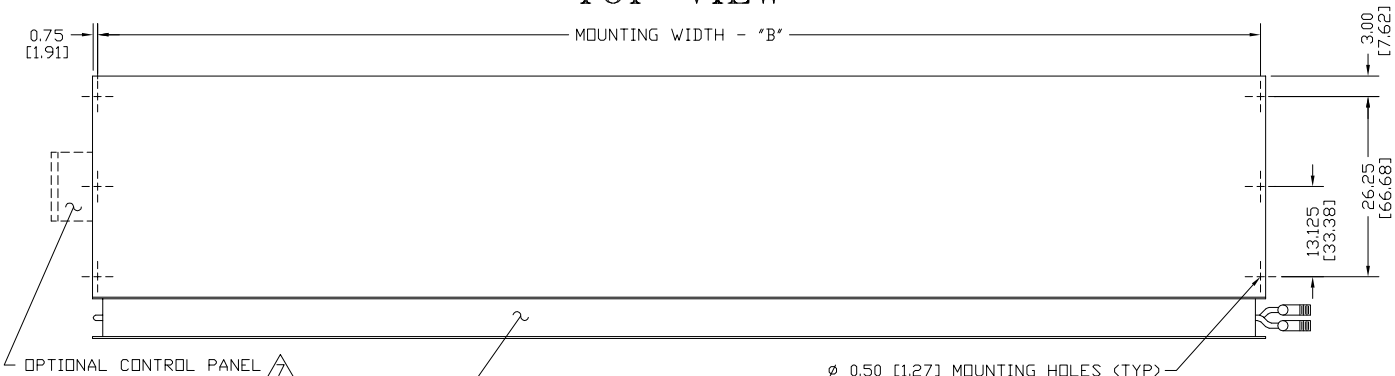

FRONT VIEW

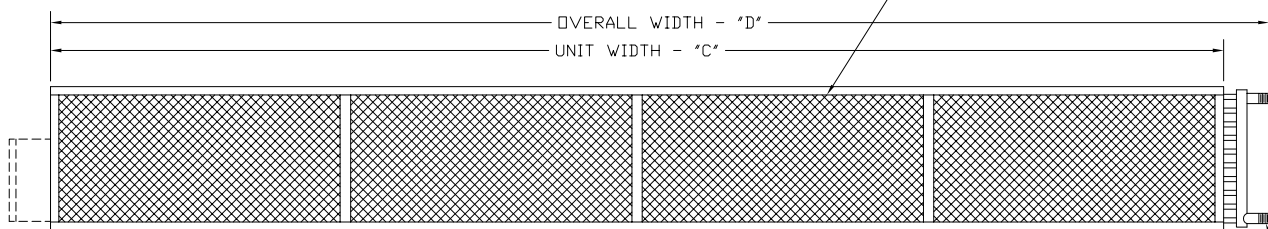

BOTTOM VIEW

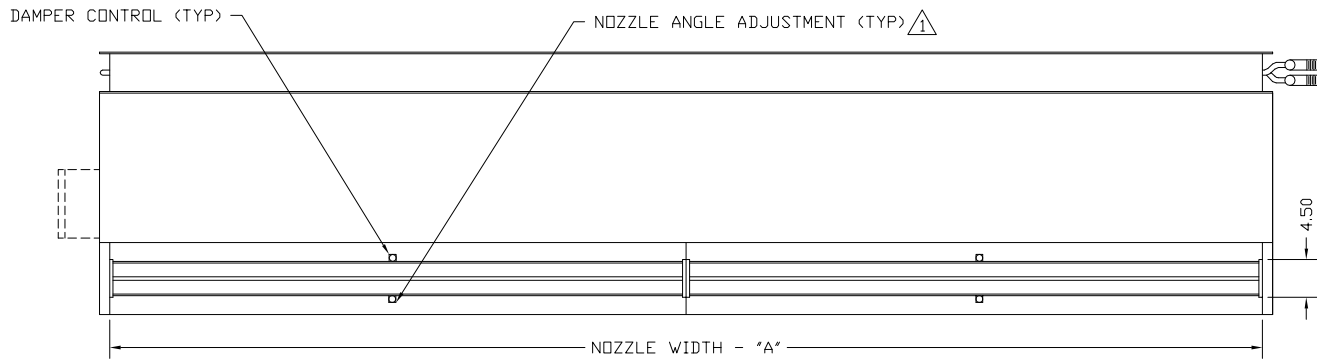

IDC20 STEAM HEATED FRONT INTAKE SAME END SUP./RET.

END VIEW

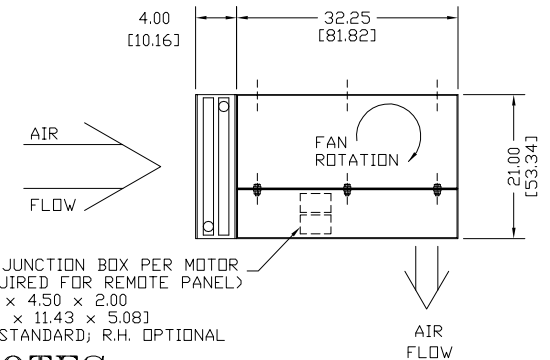

ONE JUNCTION BOX PER MOTOR
(REQUIRED FOR REMOTE PANEL)
2.75 x 4.50 x 2.00
[6.99 x 11.43 x 5.08]
L.H. STANDARD; R.H. OPTIONAL

NOTES:

- 1 AIR CURTAIN MUST BE INSTALLED SO AIR STREAM IS NOT OBSTRUCTED WHEN DEFLECTED 20° TO EITHER SIDE OF C.
- 2 ELECTRICAL CONNECTIONS TO BE FLEXIBLE.
- 3 FIELD VERIFY DIMENSIONS.
- 4 ANCHORS TO SUPPORTING STRUCTURE BY OTHERS.
- 5 ADEQUACY OF SUPPORTING STRUCTURE IS TO BE VERIFIED BY A PROFESSIONAL STRUCTURAL ENGINEER.
- 6 LETTER "S" IN MODEL NUMBER DESIGNATES, STEAM HEATED UNIT. THE "F" DESIGNATES FRONT INTAKE.
- 7 OPTIONAL CONTROL PANEL AVAILABLE: LEFT HAND MOUNT, RIGHT HAND MOUNT, OR REMOTE. PLEASE SPECIFY.
- 8 COIL CONNECTIONS AS SHOWN, OPPOSITE AND SAME END CONNECTIONS AVAILABLE, PLEASE SPECIFY.
- 9 DIMENSIONS IN INCHES [CENTIMETERS].

MODEL	NOZZLE WIDTH 'A'	MOUNTING WIDTH 'B'	UNIT WIDTH 'C'	OVERALL WIDTH 'D'
IDC20-1060S-F	60.00 [152.40]	61.50 [156.21]	63.00 [160.02]	69.50 [176.53]
IDC20-1072S-F	72.00 [182.88]	73.50 [186.69]	75.00 [190.50]	81.50 [207.01]
IDC20-1084S-F	84.00 [213.36]	85.50 [217.17]	87.00 [220.98]	93.50 [237.49]
IDC20-1096S-F	96.00 [243.84]	97.50 [247.65]	99.00 [251.46]	105.50 [267.97]
IDC20-1108S-F	108.00 [274.32]	109.50 [278.13]	111.00 [281.94]	117.50 [298.45]
IDC20-1120S-F	117.00 [297.18]	118.50 [300.99]	120.00 [304.80]	126.50 [321.31]
IDC20-1132S-F	132.00 [335.28]	133.50 [339.09]	135.00 [342.90]	141.50 [359.41]
IDC20-1144S-F	144.00 [365.76]	145.50 [369.57]	147.00 [373.38]	153.50 [389.89]
IDC20-1156S-F	156.00 [396.24]	157.50 [400.05]	159.00 [403.86]	165.50 [420.37]
IDC20-1168S-F	168.00 [426.72]	169.50 [430.53]	171.00 [434.34]	177.50 [450.85]
IDC20-1180S-F	180.00 [457.20]	181.50 [461.01]	183.00 [464.82]	189.50 [481.33]
IDC20-2192S-F	192.00 [487.68]	193.50 [491.49]	195.00 [495.30]	201.50 [511.81]

PROJECT		TITLE: BERNER
LOCATION		MODEL IDC20 AIR CURTAIN
ARCHITECT		FRONT INTAKE - STEAM HEATED SYSTEM
ENGINEER		
DWG. NO.	IDC20-STM3	
DATE	09JUNE14	
BY	S. Beil	
REPLACES	-	
BY	-	
BERNER INTERNATIONAL CORP. NEW CASTLE, PA.		

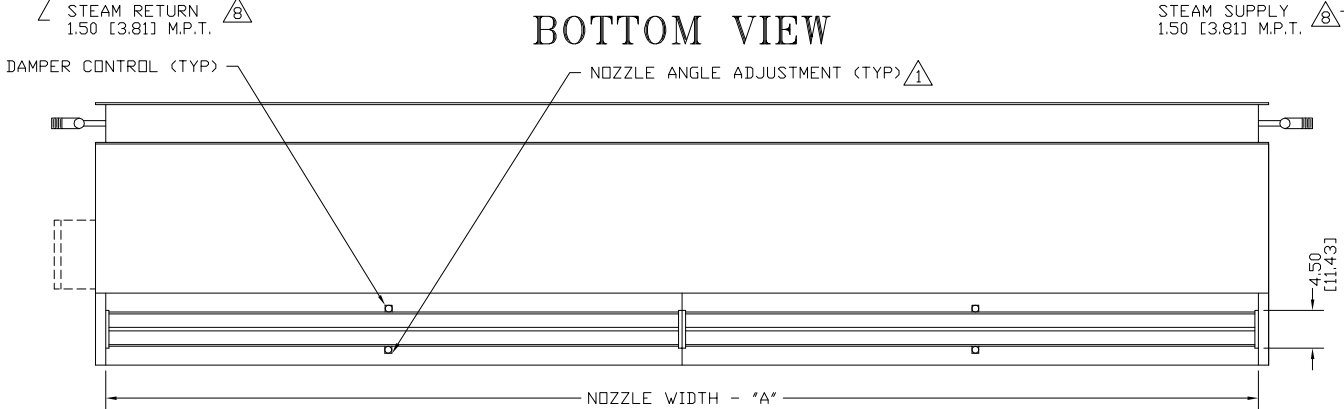
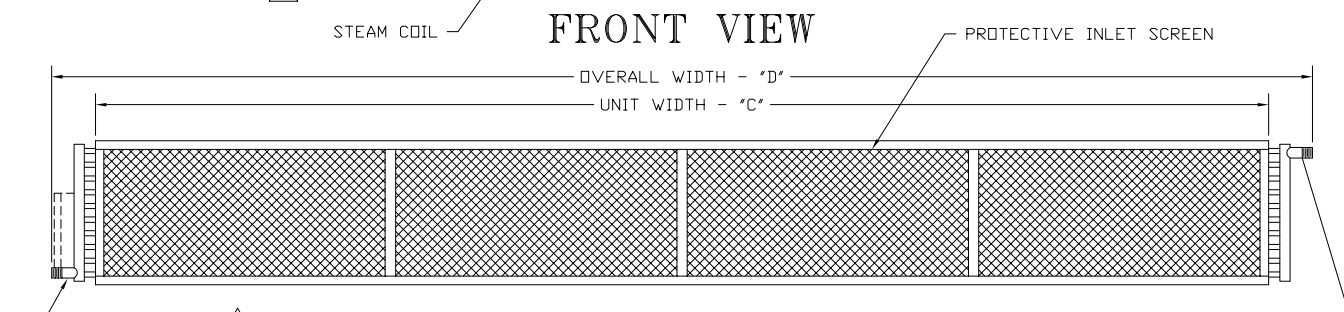
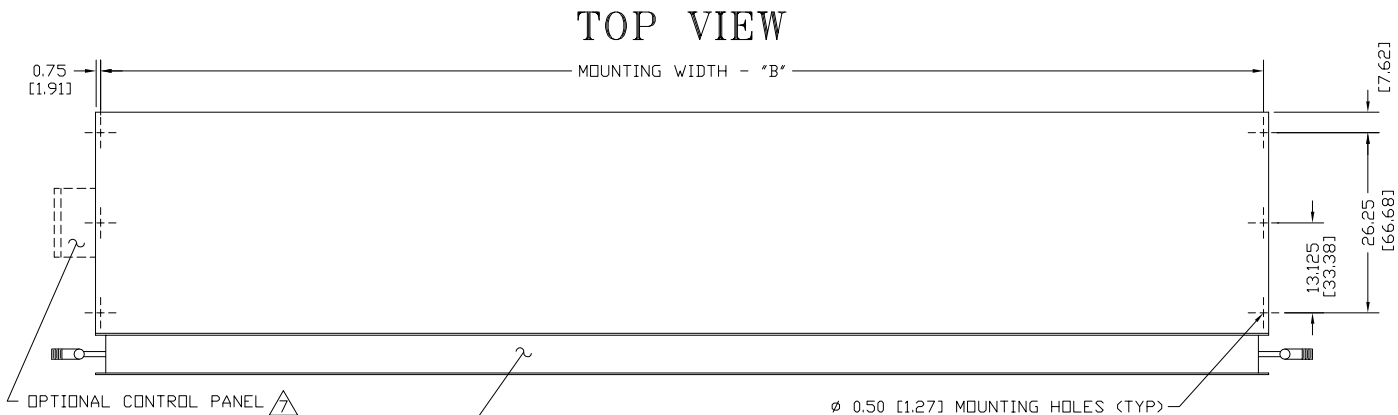

MODEL	NOZZLE WIDTH "A"	MOUNTING WIDTH "B"	UNIT WIDTH "C"	OVERALL WIDTH "D"
IDC20-1060S-F	60.00 [152.40]	61.50 [156.21]	63.00 [160.02]	76.00 [193.04]
IDC20-1072S-F	72.00 [182.88]	73.50 [186.69]	75.00 [190.50]	88.00 [223.52]
IDC20-1084S-F	84.00 [213.36]	85.50 [217.17]	87.00 [220.98]	100.00 [254.00]
IDC20-1096S-F	96.00 [243.84]	97.50 [247.65]	99.00 [251.46]	112.00 [284.48]
IDC20-1108S-F	108.00 [274.32]	109.50 [278.13]	111.00 [281.94]	124.00 [314.96]
IDC20-1120S-F	117.00 [297.18]	118.50 [300.99]	120.00 [304.80]	133.00 [337.82]
IDC20-1132S-F	132.00 [335.28]	133.50 [339.09]	135.00 [342.90]	148.00 [375.92]
IDC20-1144S-F	144.00 [365.76]	145.50 [369.57]	147.00 [373.38]	160.00 [406.40]
IDC20-1156S-F	156.00 [396.24]	157.50 [400.05]	159.00 [403.86]	172.00 [436.88]
IDC20-1168S-F	168.00 [426.72]	169.50 [430.53]	171.00 [434.34]	184.00 [467.36]
IDC20-1180S-F	180.00 [457.20]	181.50 [461.01]	183.00 [464.82]	196.00 [497.84]
IDC20-2192S-F	192.00 [487.68]	193.50 [491.49]	195.00 [495.30]	208.00 [528.32]

IDC20

STEAM HEATED FRONT INTAKE

OPP. END SUP./RET.

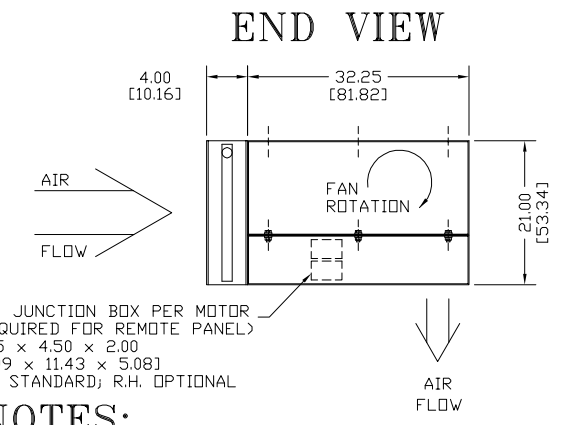

NOTES:

- 1 AIR CURTAIN MUST BE INSTALLED SO AIR STREAM IS NOT OBSTRUCTED WHEN DEFLECTED 20° TO EITHER SIDE OF CL
- 2 ELECTRICAL CONNECTIONS TO BE FLEXIBLE.
- 3 FIELD VERIFY DIMENSIONS.
- 4 ANCHORS TO SUPPORTING STRUCTURE BY OTHERS.
- 5 ADEQUACY OF SUPPORTING STRUCTURE IS TO BE VERIFIED BY A PROFESSIONAL STRUCTURAL ENGINEER.
- 6 LETTER "S" IN MODEL NUMBER DESIGNATES, STEAM HEATED UNIT. THE "F" DESIGNATES FRONT INTAKE.
- 7 OPTIONAL CONTROL PANEL AVAILABLE: LEFT HAND MOUNT, RIGHT HAND MOUNT, OR REMOTE. PLEASE SPECIFY.
- 8 COIL CONNECTIONS AS SHOWN, OPPOSITE AND SAME END CONNECTIONS AVAILABLE, PLEASE SPECIFY.
- 9 DIMENSIONS IN INCHES [CENTIMETERS].

PROJECT		TITLE:	BERNER
LOCATION		DATE	09JUNE14
ARCHITECT		BY	S. Beil
ENGINEER		REPLACES	-
		BY	-
		BERNER INTERNATIONAL CORP. NEW CASTLE, PA.	