

INTELLIS NETWORK CONTROL MONITORS

NON-HAZARDOUS, INTRINSICALLY SAFE, EXPLOSIONPROOF/FLAMEPROOF - ATEX/IEC

Intellis is a family of fully-integrated control monitors that provide cost-effective valve automation and intelligent networking via the major network protocols



FEATURES

- Dedicated network modules (PACs) for all major protocols.
- Simple in-field conversion of network protocols.
- Multiple housing options (resin, aluminum, stainless steel).
- Models approved for all hazardous area applications.
- Control & monitoring for rotary and linear valves.
- Non-contact position monitoring by Hall effect sensors.
- Integrated pneumatic actuation control via pre-wired Falcon II solenoid valves.
- On-line predictive and maintenance-related diagnostics.
- Eliminates wiring cost of conventionally-hardwired I/O systems.
- Reduces design engineering man-hours
- Range of drive shaft options.
- Visual indication Beacon available in a choice of styles and colors.

TECHNICAL DATA

Agency approvals

Area classification	3500/8500, 3800/8800 Series
Non-hazardous	3300/8300, 3600/8600 Series
Intrinsically safe	2200 Series
Explosionproof	
Enclosure standards (IEC)	
All enclosures	IP66

Network protocols supported

PROFIBUS DP	2200, 3500/8500, 3800/8800 Series
FOUNDATION Fieldbus™	2200, 3300/8300, 3600/8600 Series
DeviceNET™	2200, 3500/8500, 3800/8800 Series
AS-Interface® Ver. 3.0	2200, 3500/8500, 3800/8800 Series

Enclosures

Engineered resin
Aluminum
Stainless steel

GENERAL APPLICATION

Intellis network control monitors use embedded control systems to automate valves and link field I/O to the host PLC or DCS. They incorporate all the features of standard Westlock control monitors with the addition of a network I/O module.

INTELLIS NETWORK CONTROL MONITORS

NON-HAZARDOUS, INTRINSICALLY SAFE, EXPLOSIONPROOF/FLAMEPROOF - ATEX/IEC

NETWORK SYSTEMS FOR VALVE AUTOMATION

Intellis is a family of field network control monitors which use embedded control systems to automate valves and link field I/O to the host PLC or DCS. They incorporate all the features of standard Westlock control monitors with the addition of a network I/O module.

Each network monitor houses two discrete Hall effect sensors for valve position monitoring, a low power solenoid valve for actuation control and a network interface module for communication via the chosen network protocol. Monitors are available for linear and rotary applications in all area classifications.

THE NETWORK MODULE

Each Intellis model contains a dedicated network module (Pac) that is integrated within its enclosure. A different Pac is factory-integrated depending upon the network protocol selected. The Pacs' modular design enables the simple conversion of units from one network protocol to another (with the sole exception of FOUNDATION Fieldbus™) in the field by authorized personnel, should the need arise.

Integrated network modules have protective diodes and optical isolation as standard.

Peripheral interface devices

- Cables
- Power supplies
- Gateways
- Repeaters
- Extenders
- Configuration tools
- Software/diagnostics
- Junction boxes

STANDARD NETWORK PROTOCOLS

The development of standard network protocols has made it possible to integrate process control components into a network effectively. DeviceNet™, AS-interface®, PROFIBUS and FOUNDATION Fieldbus™ are now the standards for interfacing discrete devices. They are proven to be extremely reliable, simple to understand and consistently cost-effective. They integrate simply with all major PLCs and DCS systems via off-the-shelf gateway interfaces.

ACCESSORIES

Westlock Controls is committed to making your network design, procurement and installation experience easier. To complement our wide array of network valve monitoring and control products, we offer a variety of accessories to meet your network connectivity and power requirements. From power supplies and cables to gateways and junctions, we've got what you need to get the job done efficiently.

SERVICES

Westlock Controls also offers expert services for the design and installation of ASi®, DeviceNet™, PROFIBUS and FOUNDATION Fieldbus™ networks. This includes the specification of all equipment from the PLC or DCS down.

Application support

- Engineering design
- Integration
- Start-up support
- Training
- Turnkey installations



Network modules



Gateway interface



Active network tee (ANT)

Junction box



Interconnects

INTELLIS NETWORK CONTROL MONITORS

NON-HAZARDOUS, INTRINSICALLY SAFE, EXPLOSIONPROOF/FLAMEPROOF - ATEX/IEC

FIELD NETWORK

A field communications network comprises a specific number of network monitors interconnected by a common communications protocol. Network monitors may be placed on the field network in any physical order. Each monitor is assigned a unique address and accepts input/output signals from valve position sensors, solenoids and external devices.

Communication with a PLC, DCS or host computer is accomplished by a compatible gateway interface or scanner card.

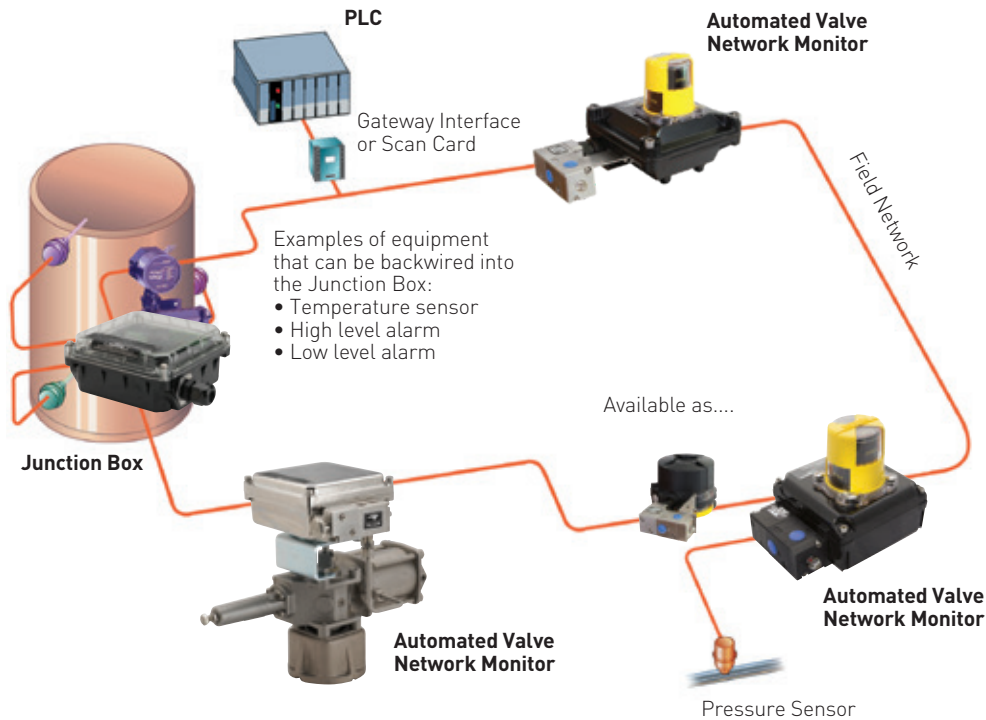

AUTOMATED VALVE NETWORK MONITOR

The network monitor for automated valves couples directly onto the pneumatic or electric actuator. Each unit can accept input/output signals from position sensors and solenoid valves while simultaneously performing on-line diagnostics. In addition, each network monitor will interact with a comprehensive range of external field devices for control or alarm purposes.

EXTERNAL DEVICE NETWORK MONITOR

Network monitors are available for control or monitoring of non-valve related devices including sensors, alarms, actuators, indicating lights, etc. Depending on the protocol, each stand-alone network monitor is capable of accepting up to six external devices within the primary control network.

INTELLIS NETWORK CONTROL MONITORS

PROFIBUS



PROFIBUS 2200, 3500/8500, 3800/8800 SERIES

PROFIBUS (Process Field Bus) has been a standard for field bus communication in automation technology since it was first developed in 1989.



PROFIBUS

Physical media	Twisted pair for communications, two wires for power
Maximum distance	1200 m (3960 feet) trunk
Maximum network monitors per system	32/segment; 126/system using repeaters
Maximum I/O points per system	1125/system
Current consumption per network monitor	120 mA
Interface capability	All PLCs and DCS supporting the PROFIBUS protocol
Communications method	Peer to peer and cyclic Master/slave
Error checking	CRC check
Network topology	Linear, preferred, drops allowed @ Baud rates below 500 kbps
Transmission speed	9.6, 19.2, 93.75, 187.5, 500, 1500, 12000 kbps
Redundancy	No
Valves specific diagnostics	Yes

NOTES

1. Please contact your sales office for guidance on selecting the best possible combination for your control and monitoring requirements.
2. See Hazardous area classification technical bulletin for further information on global standards.

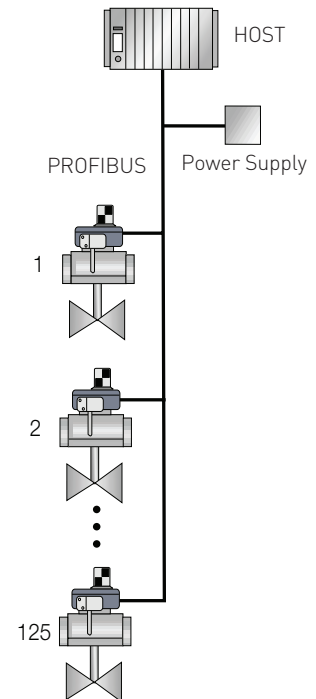

INTELLIS NETWORK CONTROL MONITORS

FOUNDATION FIELDBUS™



FOUNDATION FIELDBUS™ 2200, 3300/8300, 3600/8600 SERIES

Foundation Fieldbus is an all-digital, serial two-way communications system that is an open architecture, developed and administered by the Fieldbus Foundation.

FOUNDATION FIELDBUS™

Physical media	Two wire cable (communications and power)
Maximum distance	1900 m (6220 feet) including spurs
Maximum network monitors per system	6/segment if bus powered & IS; 12/segment if bus powered & non-IS; 32/seg. if neither bus powered nor IS
Maximum I/O points per system	192/system
Current consumption per network monitor	18-24 mA IS
Interface capability	All PLCs and DCS supporting the FF protocol
Communications method	Peer to peer
Error checking	Manchester encoding
Network topology	Daisy chain, trunk/drop (spurs), branching drop (spurs), point to point
Transmission speed	31.25 kbps
Redundancy	Yes
Valves specific diagnostics	Yes

NOTES

1. Please contact your sales office for guidance on selecting the best possible combination for your control and monitoring requirements.
2. See Hazardous area classification technical bulletin for further information on global standards.

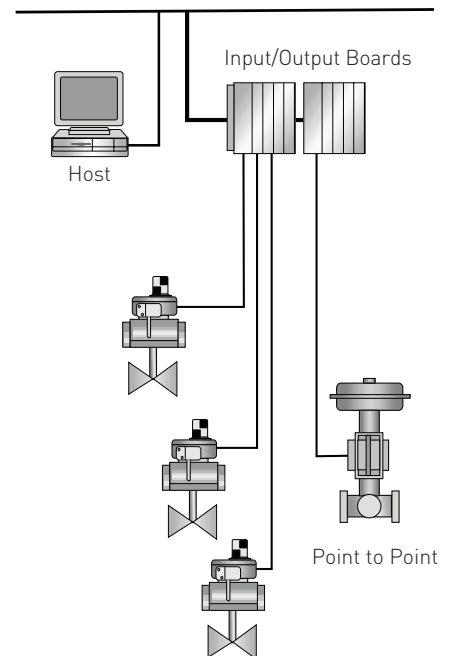

INTELLIS NETWORK CONTROL MONITORS

DEVICENET™



DEVICENET™ 2200, 3500/8500, 3800/8800 SERIES

DeviceNet™ is an open device network standard based upon proven Controller Area Network (CAN) technology.

DEVICENET™

Physical media	Twisted pair for communications, two wires for power
Maximum distance	1600 ft.(485 m) trunk + 512 ft. (155 m) drop
Maximum network monitors per system	63/network; 2 networks/system
Maximum I/O points per system	378/network plus optional 4/20mA analog I/O 756/system
Current consumption per network monitor	45 mA + 20-25 mA/coil
Interface capability	All PLCs and DCS with DeviceNet™ Interface
Communications method	Master/slave multimaster, peer-to-peer
Error checking	CRC check
Network topology	Zero drop, trunk/drop, daisy chain, branch
Transmission speed	125 kbps, 250 kbps, 500 kbps
Redundancy	No
Valves specific diagnostics	Yes

NOTES

1. Please contact your sales office for guidance on selecting the best possible combination for your control and monitoring requirements.
2. See Hazardous area classification technical bulletin for further information on global standards.

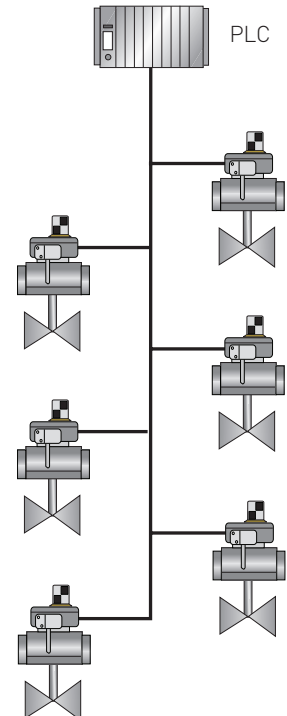

INTELLIS NETWORK CONTROL MONITORS

AS-INTERFACE® VER. 3.0



AS-INTERFACE® VER. 3.0 2200, 3500/8500, 3800/8800 SERIES

The AS-Interface® protocol was developed by a consortium of major European companies. Designed specifically for use in low level automated systems, AS-i can communicate via a gateway to most higher-level bus systems such as DeviceNet™, Modbus® and PROFIBUS.



AS-INTERFACE® VER. 3.0

Physical media	Two wire cable (communications and power)
Maximum distance	300 ft. (90.9m) 900 ft. (273 m) with repeater
Maximum network monitors per system	62/network with 2.1 Master ,1 network/system
Maximum I/O points per system	434/network, 434/system
Current consumption per network monitor	(2 in/2 out) 11 mA (power) - 59 mA (1 in/1 out)
Interface capability	All PLC's and DCS with ModBus®, DeviceNet™, PROFIBUS port
Communications method	Master/slave with cyclic polling
Error checking	Control sum, parity
Network topology	Trunk/drop, zero drop
Transmission speed	167 kbps
Redundancy	No
Valves specific diagnostics	No

NOTES

1. Please contact your sales office for guidance on selecting the best possible combination for your control and monitoring requirements.
2. See Hazardous area classification technical bulletin for further information on global standards.

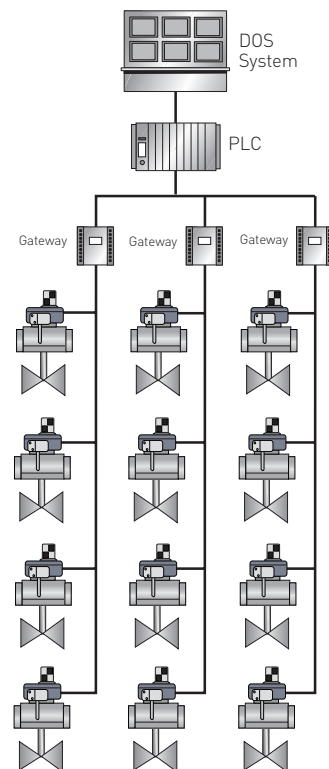

INTELLIS NETWORK CONTROL MONITORS

ALUMINUM AND STAINLESS STEEL ENCLOSURE DIMENSIONS

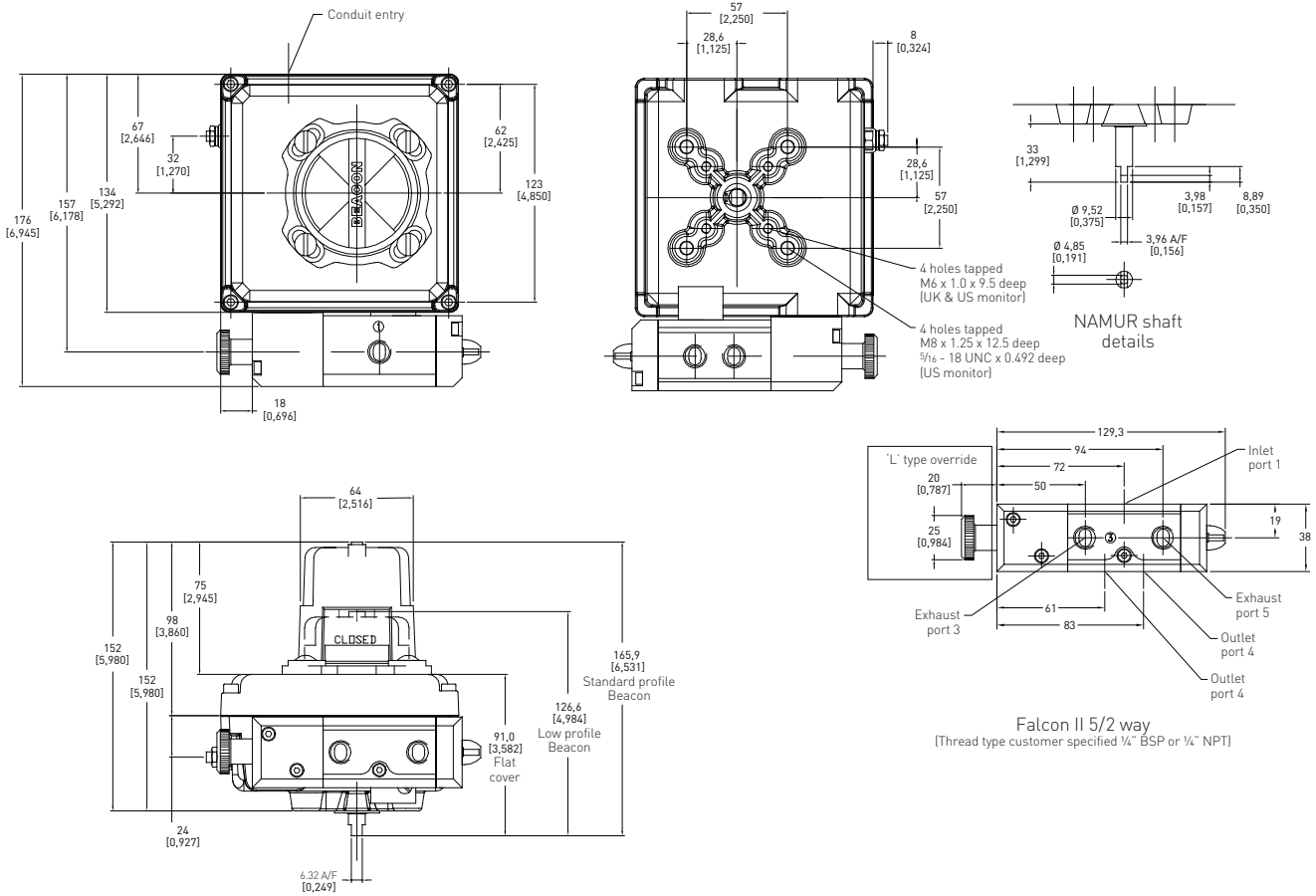

Dimensions in mm, imperial dimension (inches) in parentheses

TECHNICAL SPECIFICATIONS

Materials of construction

Enclosure	Aluminum with powder coat finish Stainless steel with electropolished finish"
Shaft and hardware	Stainless steel
Beacon visual indicator	Co-polyester
Bushing	Oil impregnated bronze (aluminum enclosure) Nylon (stainless steel enclosure)

Drive shaft

Westlock standard	Double-D with 1/4" A/F
NAMUR standard	NAMUR standard VDI/VDE 3845

NOTES

- Intellis control monitors are available with a choice of conduit entries. Please see the selection guide for standard entries
- Please consult your sales office for any other requirements

SOLENOID VALVES

The Falcon range of solenoid valves allows you to choose the material, voltage, number of ports, number of coils and C_v to best suit your application. See the Falcon II data sheet for more information.

INTELLIS NETWORK CONTROL MONITORS

ENGINEERED RESIN ENCLOSURE (SINGLE COIL) DIMENSIONS

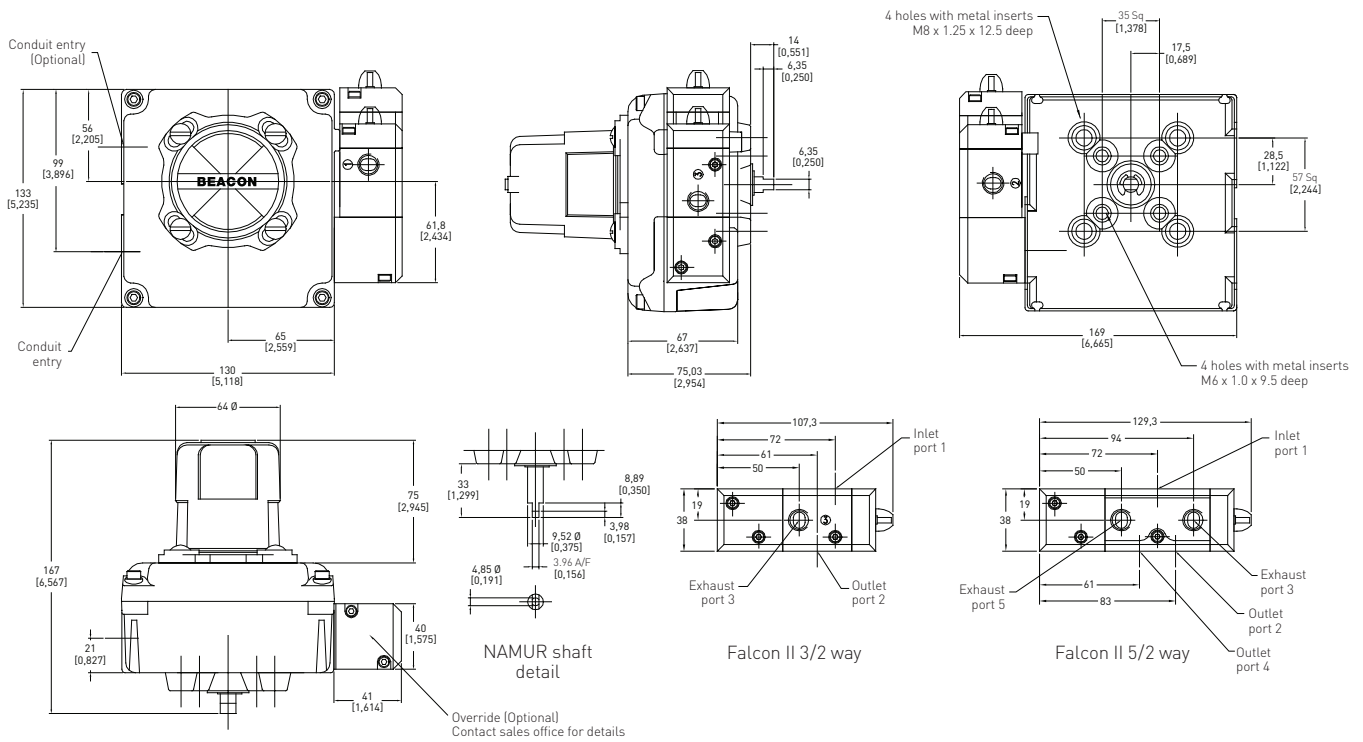

Dimensions in mm, imperial dimension (inches) in parentheses

TECHNICAL SPECIFICATIONS

Materials of construction

Enclosure	Engineered resin
Shaft and hardware	Stainless steel
Beacon visual indicator	Co-polyester
Bushing	Nylon
Drive shaft	
Westlock standard	Double-D with 1/4" A/F
NAMUR standard	NAMUR standard VDI/VDE 3845

NOTES

- Intellis control monitors are available with a choice of conduit entries. Please see the selection guide for standard entries
- Please consult your sales office for any other requirements

SOLENOID VALVES

The Falcon range of solenoid valves allows you to choose the material, voltage, number of ports, number of coils and C_v to best suit your application. See the Falcon II data sheet for more information.

INTELLIS NETWORK CONTROL MONITORS

ENGINEERED RESIN ENCLOSURE (DUAL COIL) DIMENSIONS

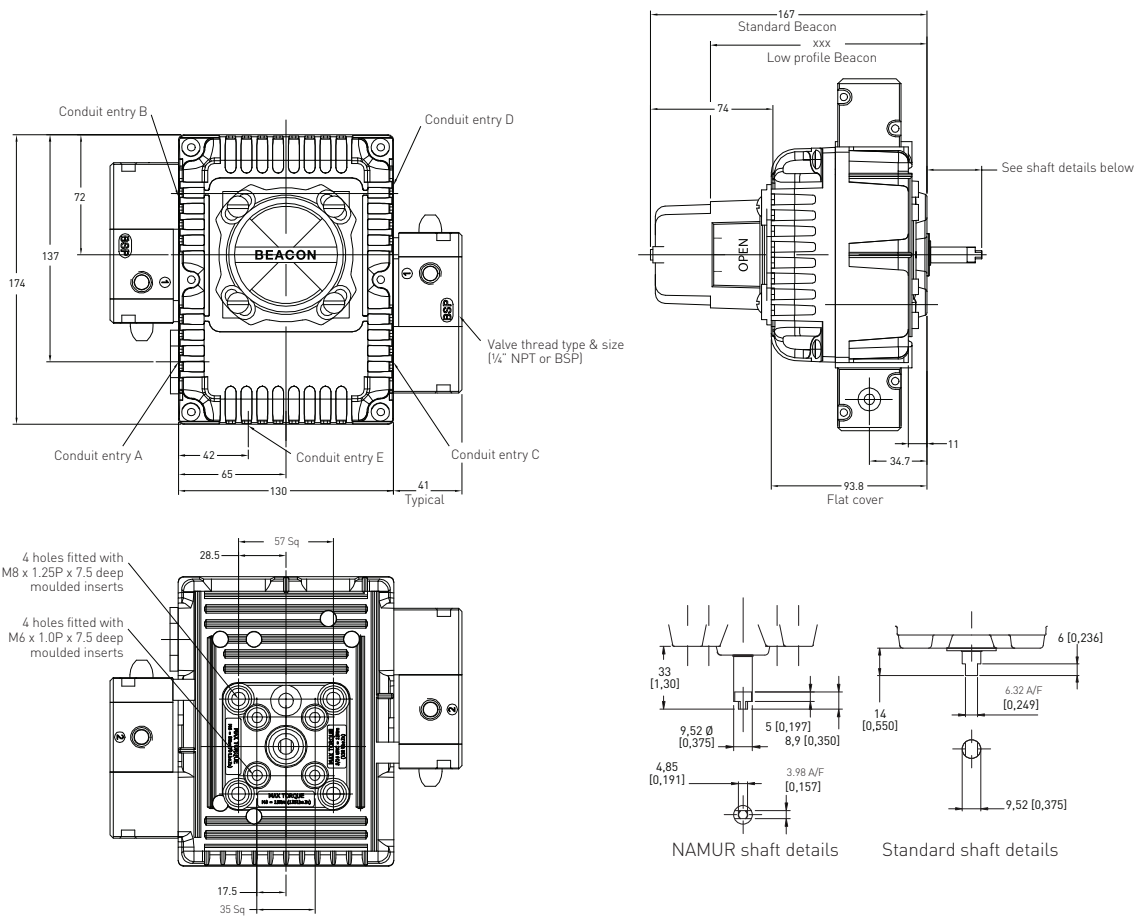

Dimensions in mm, imperial dimension (inches) in parentheses

TECHNICAL SPECIFICATIONS

Materials of construction

Enclosure	Engineered resin
Shaft and hardware	Stainless steel
Beacon visual indicator	Co-polyester
Bushing	Nylon
Drive shaft	
Westlock standard	Double-D with 1/4" A/F
NAMUR standard	NAMUR standard VDI/VDE 3845

SOLENOID VALVES

The Falcon range of solenoid valves allows you to choose the material, voltage, number of ports, number of coils and C_v to best suit your application. See the Falcon II data sheet for more information.

NOTES

- Intellis control monitors are available with a choice of conduit entries. Please see the selection guide for standard entries
- Please consult your sales office for any other requirements

INTELLIS NETWORK CONTROL MONITORS

SELECTION GUIDE

Intellis

22	2200 Flameproof enclosure - available with or without solenoid valve	83	8300 Intrinsically safe enclosure - not available with solenoid valve
33	3300 Intrinsically safe enclosure - not available with solenoid valve	86	8600 Intrinsically safe enclosure - includes solenoid valve
36	3600 Intrinsically safe enclosure - includes solenoid valve	85	8500 Non hazardous enclosure - not available with solenoid valve
35	3500 Non hazardous enclosure - not available with solenoid valve	88	8500 Non hazardous enclosure - includes solenoid valve
38	3500 Non hazardous enclosure - includes solenoid valve		

Cover style

- 4 With Beacon
- 6 Flat cover

Position switches

- 9 Inbuilt Hall effect sensors

Enclosure material

- R Engineered resin
- A Aluminum
- S 316 stainless steel

Beacon type

BY	Black/yellow standard height BM2-Y(std)	B1	90° Flow path BM3-1
LY	Black/yellow low profile height	B3	90° Flow path BM3-3
GR	Red/green standard height BM2-RG	B5	90° Flow path BM3-5
AR	ANSI Red/white standard height BM2-R	B7	180° Flow path BM3-7
00	Flat cover (no beacon)	B9	180° Flow path BM3-9

Drive shaft output

- S Standard Westlock shaft (double-D with 6.32 mm/ 1/4" Flats)
- N NAMUR std spec shaft VDI/VDE 3845
- * Non-standard material & build code - consult with sales office for details/other options

Solenoid body material

- 0 Not fitted
- A Anodized aluminium
- * Non-standard build - consult with sales office for details
- E A stainless steel

Solenoid coil voltage

0	Not fitted	G	90-120 V DC
C	24 V DC	H	90-120 V AC
D	24 V AC	I	220-240 V DC
E	48 V DC	J	220-240 V AC
F	48 V AC		

Solenoid valve specification

- 0 Not fitted
- U Falcon II, 3/2-way, 1.1 C_v, 1/4" NPT entry - fail closed
- V Falcon II, 3/2-way, 1.1 C_v, 1/4" NPT entry - fail open
- 1 Falcon II, 5/2-way, 1.1 C_v, 1/4" NPT entry - fail closed
- K Falcon II, 3/2-way, 1.1 C_v, 1/4" BSP entry - fail closed
- L Falcon II, 3/2-way, 1.1 C_v, 1/4" BSP entry - fail open
- Q Falcon II, 5/2-way, 1.1 C_v, 1/4" BSP entry - fail closed
- * Non-standard build - consult with sales office for details

Switch/sensor quantity

- 2 Two inbuilt sensors - all enclosures

Conduit

- 2 Two conduit entries - all enclosures
- 3 Three conduit entries - check availability with sales office
- 4 Three conduit entries - check availability with sales office
- 5 Four conduit entries - check availability with sales office

Unit Specification

- GAN Fitted with Asi Netpac - std material & build
- UAV Fitted with DeviceNet Netpac - std material & build
- BGY Fitted with Foundation Fieldbus Netpac - std material & build
- BIP Fitted with Profibus Netpac - std material & build
- *** Non-standard material & build code - consult with sales office for details/other options

Certification

- 0 Non-hazardous
- A ATEX
- I IECEx
- * Other options - consult with sales office for details

Revision

- R* Internal Westlock revision number

22 4 9 A BY N 0 0 0 2 2 GAN -A R1 = Model number **2249ABYN00022GAN-AR1**



www.westlockcontrols.com

Westlock. We reserve the right to change designs and specifications without notice.