



5X MORE
PRECISE
than standard
regulators



B6R Series

Blockage Resistance Back Pressure Regulator

GAS, LIQUID & MIXED PHASE SERVICE: DESIGNED FOR SUPERCRITICAL APPLICATIONS

APPLICATION HIGHLIGHT

Pressure Control for Supercritical Extraction

In supercritical carbon dioxide (SCO₂) extraction processes, pressure control is extremely important for product quality and consistency. The schematic below is a simplified version for illustration purposes but shows how an Equilibar® B6R Series back pressure regulator (BPR) can be used in this process.

The Equilibar B6R series BPR controls pressure very accurately and is able to hold the extraction pressure precisely at the required setpoint regardless of fluctuations in the system flow rate or variations in the system temperature. This allows for more precise targeting of the desired extract. The B6R design also resists blockage from oils that have become highly viscous due to the extreme cold of the expanding gasses.

In the final stage of the process, during separation, the SCO₂ is decompressed for recycling and the blockage resistant design of the B6R Series becomes even more important. The expansion of the supercritical fluid during this pressure let-down stage is often problematic. The Joules-Thompson effect causes a dramatic temperature drop which can lead to ice formation that may block the internal passages of the BPR. The Equilibar B6R Series BPR is specifically designed to resist the buildup of ice in its internal passages.

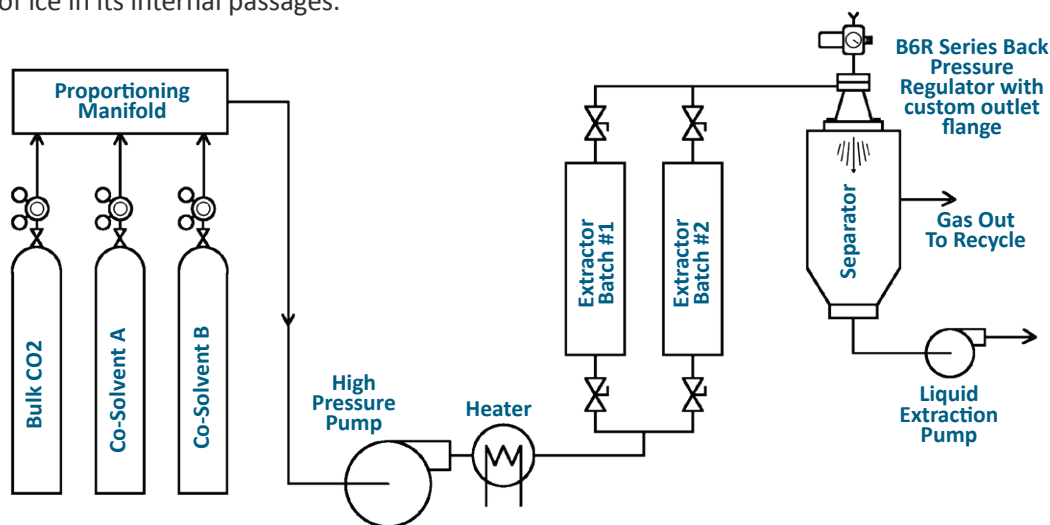

Schematic of supercritical extraction process using an Equilibar B6R Series model with custom outlet flange at the separator vessel.

OTHER APPLICATIONS

There are a variety of potential applications for the unique capabilities of the Equilibar B6R Series, designed for supercritical fluid applications where precision is paramount. Suggested uses include:

- Controlling refrigerant vapor pressure for isothermal evaporator control
- Supercritical Fractional Separation
- Plant Matter Extraction

Please contact an Equilibar engineer to discuss your application.

PATENTS

These regulators are subject to one or more of these patents: US6,886,591, US7,080,660, US7,673,650, US8,215,336, DE60322443D1, GB1639282, FR1639282



Custom model Equilibar® B6R with added feature for heating cartridge. Contact us for more details.

Key Performance Advantages

The Equilibar® B6R models are variants of the popular Equilibar Research Series back pressure regulators and are suited for controlling fluids up to 6000 psi. Equilibar has had great success in supercritical applications with the Research Series models and the new B6R Series technologies were designed with the help and feedback from those customers, optimizing for supercritical applications.

These new technologies maintain high precision control while reducing the Joule-Thomson effect of supercritical process fluids passing through the outlet orifices.

UNIQUE EQUILIBAR TECHNOLOGY

- Dome-loaded pilot regulated design is 5X more precise than traditional spring-loaded regulators
- Frictionless flexible diaphragm is the only moving part
- Apply pressure to the dome of the Equilibar back pressure regulator at the desired setpoint and the BPR does the rest
- Two modes of operation
 1. Manual adjustment by mechanical pilot regulator
 2. Computer automation by electronic pilot regulator

A key design feature of this regulator series is a downstream expansion cavity that provides a continuously increasing cross sectional area to eliminate convergence points for ice accumulation. Additionally, this large thermal mass provides an increased heat transfer area for the fluid at the outlet. Specially designed O-ring grooves reduce stress during rapid decompression which increases O-ring life.

Canadian Registration Number (CRN) certification available on some models for all territories and provinces.

SUPERCritical DESIGN ADVANTAGES

- Precision within 2%
- Pressure up to 6000 psig (413 Bar)
- Temperature up to 300°C (572°F)
- Blockage and freezing resistant
- Excellent performance in mixed phase conditions
- Suitable for ultrapure and aggressive chemicals
- Custom options for specific applications

[Follow this link to watch how it works](#)

Ordering Information items listed in blue are in stock for faster delivery

| EXAMPLE | | | | | | | | | | | | | | | | | |
|---------|---|---|---|---|---|---|---|---|---|---|------|---|-----|----|----|-----|----|
| B6R | 3 | S | N | N | X | - | N | S | X | P | 2000 | T | 150 | K | X | KKK | B |
| | | | | | X | - | | | X | P | | T | | | X | | |
| 1 | 2 | 3 | 4 | 5 | 6 | - | 7 | 8 | 9 | | 10 | | 11 | 12 | 13 | 14 | 15 |

| | | |
|----------|----------------------|--|
| 1 | MODEL | B6R Blockage Resistant |
| 2 | PORT SIZE | 2 1/4" 3 3/8" |
| 3 | BODY MATERIAL | S Stainless Steel 316/316L |
| 4 | PORT OPTIONS | N NPT T Tube stub X Custom Flange. Contact Factory |
| 5 | TRIM | N Standard |

| | | |
|-----------|----------------------------------|--|
| 6 | REVISION # | Factory Selected |
| 7 | REFERENCE PORT THREADS | N NPT |
| 8 | CAP MATERIAL (NON-WETTED) | S Stainless Steel 316/316L |
| 9 | BOLTS | Factory Selected |
| 10 | PRESSURE RATING (PSIG) | Maximum pressure you request your unit to be configured for. Cannot exceed 6000 psi. |
| 11 | TEMPERATURE RATING (°C) | Maximum temperature you request your unit to be configured for. |

| | | |
|-----------|----------------------------|---|
| 12 | DIAPHRAGM MATERIAL | I Polyimide K PEEK O FDA PEEK |
| 13 | DIAPHRAGM THICKNESS | Factory Selected |
| 14 | O-RING MATERIAL | KKK Kalrez® Grade 7075 LLL Kalrez® Grade 7090 EEE EPDM |
| 15 | SPECIAL OPTIONS | B Mounting Bracket Kalrez® is a registered trademark of DuPont |

Equilibar offers custom configurations with special features such as a heating cartridge, thermocouple ports, or flanged outlets. Other diaphragm and O-ring material may also be available. [Contact an application engineer](#) for assistance.

About Equilibar

Equilibar provides innovative and robust pressure and flow control technology for researchers and engineers worldwide. We are proud to design, manufacture, and test our patented back pressure regulators in our factory overlooking the Blue Ridge Mountains near Asheville, NC, and we are equally proud to work with clients around the world each and every day.

APPLICATION ENGINEERING— WHAT SETS US APART

Unlike mass-market regulator distributors, we focus on working with you, the scientist or engineer with a complex pressure control scenario.

Our application engineers work collaboratively with clients to identify the optimal model, trim, and diaphragm for each application's unique challenges. No matter where you are on the globe, you can stay in close contact with your engineer by email, telephone, videoconferencing, or fax.

After installation, your application engineer will support you with start-up information and fine-tuning as needed.



Equilibar, LLC
320 Rutledge Rd.
Fletcher, North Carolina 28732
United States
Tel: +1-828-650-6590
Fax: +1-801-504-4439
Monday - Friday
8:00 AM - 5:00 PM EST
12:00 - 21:00 GMT
inquiry@equilibar.com



Each application is reviewed by our engineering team to ensure quality performance of our products.

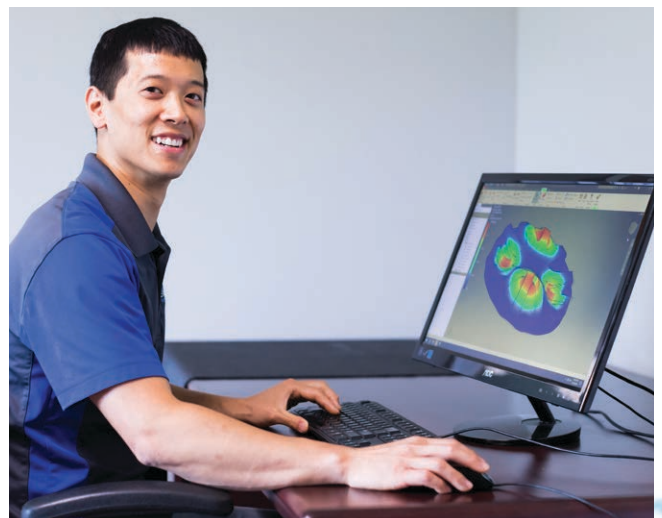

Our engineers offer custom designed solutions for the most difficult pressure control challenges. Feel free to contact us to discuss your situation.



Made in the
USA

Equilibar's quality system is
ISO 9001:2015 certified.