

# WL34

## Articulated Wheel Loaders



**WACKER  
NEUSON**  
*all it takes!*



### **Articulated wheel loader offers optimum power and fuel economy: WL34**

The WL 34 is equipped with a powerful 48HP Perkins T4F diesel engine. With the universal attachment plate, Faster Hydraulic Block, and 14-pin auxiliary electrical harness all standard, operating attachments is quick and easy. The operator's station is ergonomically laid out for

comfort and convenience. The ergonomically designed multifunctional joystick with integrated auxiliary controls allows for easy attachment operation. Excellent 360° visibility, especially in confined areas.

- Standard aux hydraulic flow of 16 gpm (73 l/min)
- Universal attachment plate makes this machine an ideal carrier for a variety of jobs
- Faster quick connect hydraulic connections with 14-pin wiring harness is standard.
- Ergonomic and spacious cab provides comfortable operation
- Fertilizer version includes standard kinematics adapter and optional anti-corrosion coating. Fertilizer edition also is available with M-Drive that provides constant engine rpm and no inch brake to deliver maximum power, reducing cycle times and increasing operator efficiency

## WL34 Technical specifications

<b>Engine / Motor</b>	
Engine / Motor manufacturer	Perkins
Engine / Motor type	404F-22
Cylinder	4
Engine performance	48 hp
at rpm maximum	2,600 rpm
Displacement	135.18 in <sup>3</sup>
Coolant type	water
<b>Electrical system</b>	
Operating voltage	12 V
Battery	77 Ah
Alternator	77 A
<b>Weights</b>	
Operating weight	7,209.04 lb
Lifting force maximum	8,331 lb
Breakout force maximum	9,952 lbf
<b>Vehicle data</b>	
Bucket capacity Standard bucket	0.78 yd <sup>3</sup>
Speed Stage 1:	0-4.35 mph
Speed Stage 2:	0-12.43 mph
<b>Hydraulic system</b>	
Driving hydraulics - operating pressure	6,526.8 psi
Operating hydraulics - operating pressure	3,045.84 psi
Operating hydraulics - discharge capacity	12.94 US gpm
<b>Filling capacities</b>	
Tank capacity (fuel)	14.52 US gal
Engine oil	8.45 US qt
Hydraulic oil tank	68.69 US qt
Hydraulic system	79.25 US qt
Coolant	10.57 US qt
Front axle	4.23 US qt
Rear axle	4.97 US qt
<b>Sound level</b>	
Cabin - specified sound pressure level LpA	75 dB(A)
Sound level (LwA)	101 dB(A)

Standard bucket = digging bucket, 1,650 mm width

## WL34 Dimensions

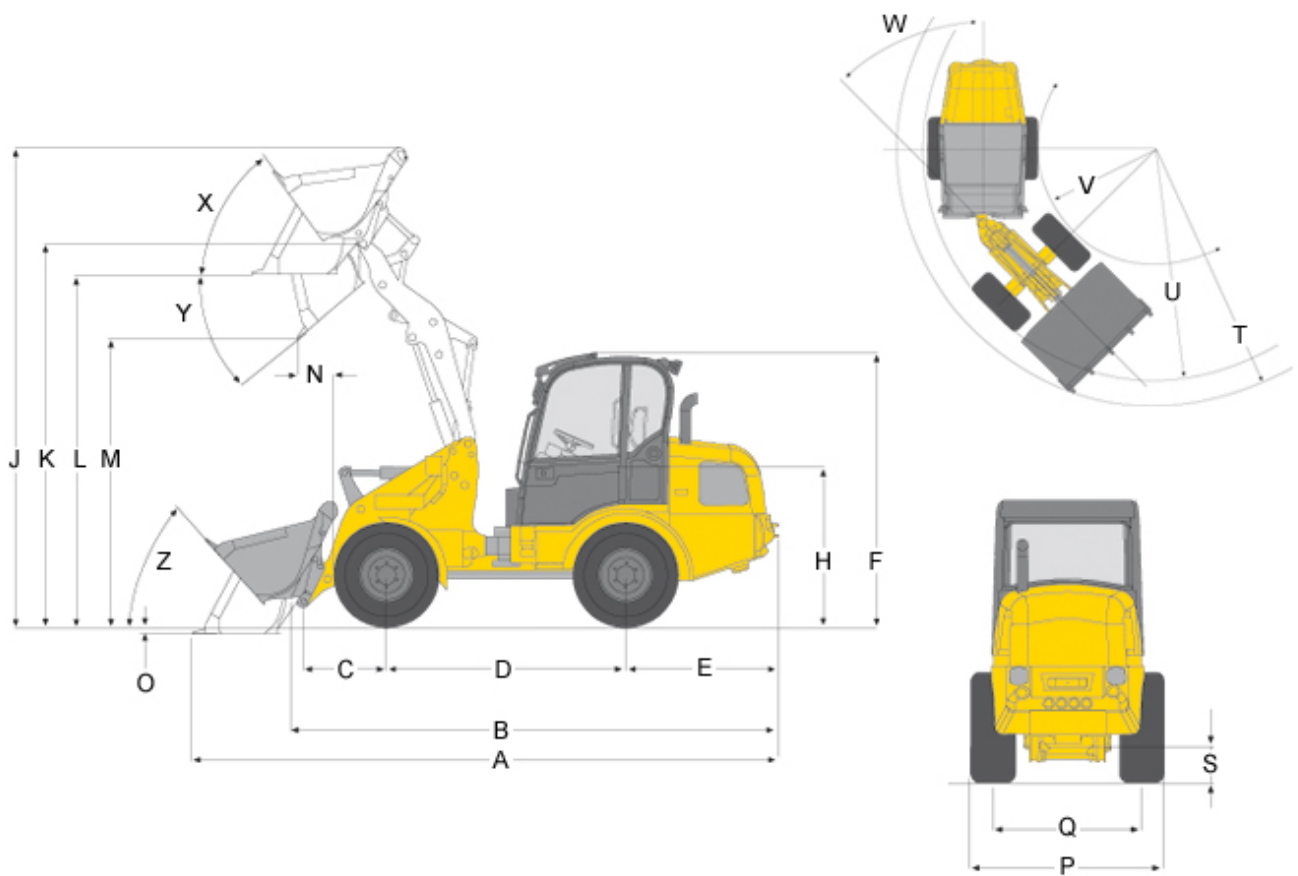

A	Overall length	195.3 in
B	Overall length without bucket	162.4 in
C	Bucket pivot point to axle center	27.6 in
D	Wheelbase	79.5 in
E	Rear overhang	51 in
F	Height with driver's canopy	88.5 in
	Height with cabin	91.9 in
H	Seat height	46 in
J	Total operating height	153.6 in
K	Stroke height max. - bucket pivot point	126.8 in
L	Overhead loading height	117.5 in
M	Dump height max.	96.2 in
N	Range at M	13.5 in
O	Scraping depth	1.3 in
P	Overall width	61.8 in
Q	Track width	49.6 in
S	Ground clearance	11.6 in
T	Radius maximum	138.2 in
U	Radius at outer edge	126.7 in
V	Inside turning radius	68.7 in

W	Articulation angle	45 °
X	Bucket rollback at max. stroke height	54 °
Y	Dump angle maximum	40 °
Z	Bucket rollback at ground level	48 °

Please note: that product availability can vary from country to country. It is possible that information / products may not be available in your country. More detailed information on engine power can be found in the operator's manual; the stated power may vary due to specific operating conditions. Subject to alterations and errors excepted. Applicable also to illustrations.  
Copyright © 2020 Wacker Neuson SE.