

Ground-engaging telehandler



**WACKER
NEUSON**

all it takes!



Reaching new heights in versatility.

TH522

Loading, moving, lifting, placing - the Wacker Neuson TH522 handles a lot. But there's more. This highly versatile telehandler extends your productivity with ground engaging capabilities. With the right Wacker Neuson attachments, the TH522 allows you to dig into new challenges on the job site.

1. What you expect from a telehandler.

With a lift height of 16 ft. 7 in. (5,056 mm) and an operating capacity of 4,080 pounds (1,850 kg) with forks, the TH522 provides the reach needed to accomplish a variety of tasks quickly and efficiently.

2. What you need from a wheel loader.

The TH522's robust and performance-driven design, including a 60-horsepower Tier 4 Final Turbo-charged Perkins engine, provide the digging and carrying capabilities of a powerful wheel loader.

3. The added benefits of a skid steer.

A compact footprint, standard universal attachment plate and quick-connect hydraulic connection block give the TH522 the maneuverability and versatility of a skid steer.





Maximum performance and versatility that give you a competitive edge every day.



Hydrostatic all-wheel drive with an inching brake pedal provides maximum power, while ample ground clearance and off-road mobility handle varied terrain.

Perkins 60 hp Tier 4 Final engine delivers performance and speed on the job site.

Large folding engine cover allows easy access to all service points and promotes quicker service and maintenance.

Designed with comfort in mind, the cab features ergonomic joystick controls and 360° panoramic views.



Multiple lift modes maximize efficiency for repetitive tasks.

16' 7" reach height makes dumping and stacking easy.

Universal attachment plate ensures quick attachment changes and the use of a variety of material handling tools.

Raising the bar on safety and convenience.

The TH522 is equipped with the Vertical Loading System (VLS). This allows the operator to choose between Bucket Mode and Fork Load to help prevent vehicle tipping in the longitudinal direction during static operation. This ensures maximum protection for the operator and machine.



Fork Mode extends and retracts the boom automatically when the operator raises the arm, in order to keep the load in a vertical plane. This is ideal for shelf loading and similar tasks. By operating similar to a forklift, the operator does not have to adjust (extend/retract) the boom while loading. In addition, a digital display monitors the load on the machine and both visually and audibly alerts the operator that the machine is at-risk of tipping.

Advantages:

- Enables pallets to be positioned precisely.
- The workflow is never interrupted by a shutdown of the hydraulic functions.
- Maximum protection for the operator and machine, even with high lifting heights.

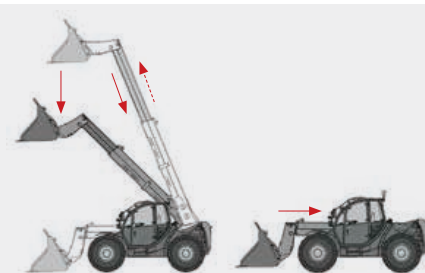

Bucket Mode automatically retracts the bucket when lowering the boom. The ratio of the retraction to lowering movement is designed so that the machine does not go into the overload range, even with maximum payload. The automatic retraction can be overridden with the joystick until reaching the overload limit.

Advantages:

- Smart handling automatically carries out two work steps that increase the efficiency of the loading cycle and makes life easier for the operator.
- The workflow is never interrupted by a shutdown of the hydraulic functions.
- Maximum protection for the operator and machine, as the telescopic arm is always completely retracted when pushing material.

For details on VLS, please refer to the operator's manual.

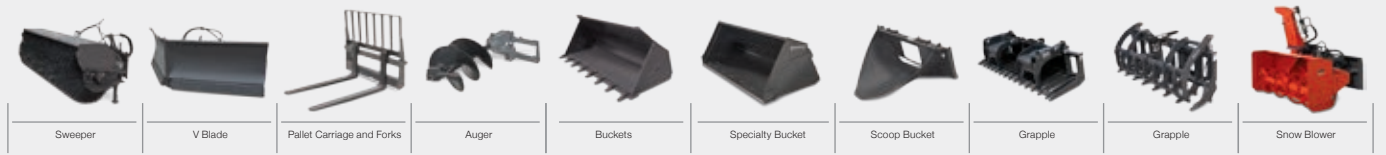

The universal skid steer attachment mounting plate makes it easier for you to adapt a wider variety of existing skid steer attachments.



Easy to access auxiliary hydraulic quick connects.



Height indicator is conveniently located on the side of the boom for easy visibility.

Comfort, control and excellent visibility give you a lift on the jobsite.

Wacker Neuson ground-engaging telehandlers are strong and quick. They have been built with the operator in mind for enhanced safety and efficient operation in all circumstances. The perfect all-round visibility and the ergonomic placement of the operator's controls make the difference.



Maximum Control

The innovative, illuminated joystick provides perfect control of the machine and its functions.



- **Less operator stress:** Work in your own personal comfort zone with the adjustable steering column, well-designed seat and extra legroom.
- **Ergonomics:** The joystick is designed to help make work easier by providing convenient control of the auxiliary hydraulics.
- **Visibility:** An unobstructed view of the attachment and working area makes it easier to concentrate on the essentials and safety.

All-wheel steering:

Full maneuverability and power development in the smallest area.

Front drum steering:

Allows safer driving at higher speeds.

Crab steer:

Ultra-precise maneuverability in tight spaces.

With a small inside turning radius of 27 inches, the TH522 is flexible enough to deliver great performance in a variety of operating environments.



Wacker Neuson telehandlers offer excellent access to all components for quick and easy service and maintenance work to get you back on the job faster.

Technical data

TH522

ENGINE		UNIT
Make / Model		Perkins 404F-22T
Type		Turbo-charged, water-cooled, 4-cylinder diesel engine
Max. operating power at operating speed	hp (kW) / rpm	61 (44.7) / 2,800
Displacement	in ³ (cm ³)	135 (2,216)
Fuel tank capacity	gal (l)	18.5 (70)
Operating voltage	V	12
Battery	A	77
Alternator	A	85
Axle	PAL	1,530
PERFORMANCE		UNIT
Drive speed	mph (km/h)	0 – 18.6 (0 – 30)
Speed stages		2
Drive system		Hydrostatic
Traction drive		Universal joint shaft
Total carriage rotation angle		144°
Total pivoting		16°
Steering angle (max.)		±40°
Lifting cylinder: raise / lower	sec	6.2 / 4.2
Extension cylinder: extend / retract	sec	5.1 / 2.5
Tipping cylinder: crowd / tilt	sec	3.1 / 2.2
HYDRAULICS		UNIT
Operating pressure	psi (bar)	6,527 (450)
Aux hydraulic flow	gal (l)/min	18.4 (70)
Steering pressure	psi (bar)	3,263 (225)
Hydraulic oil tank capacity	gal (l)	14.5 (55)
CAPACITY		UNIT
Max. load - forks	lbs (kg)	4,080 (1,850)
Max. load - bucket	lbs (kg)	3,200 (1,450)
NOISE LEVEL		UNIT
Noise level (LwA)	dB (A)	103

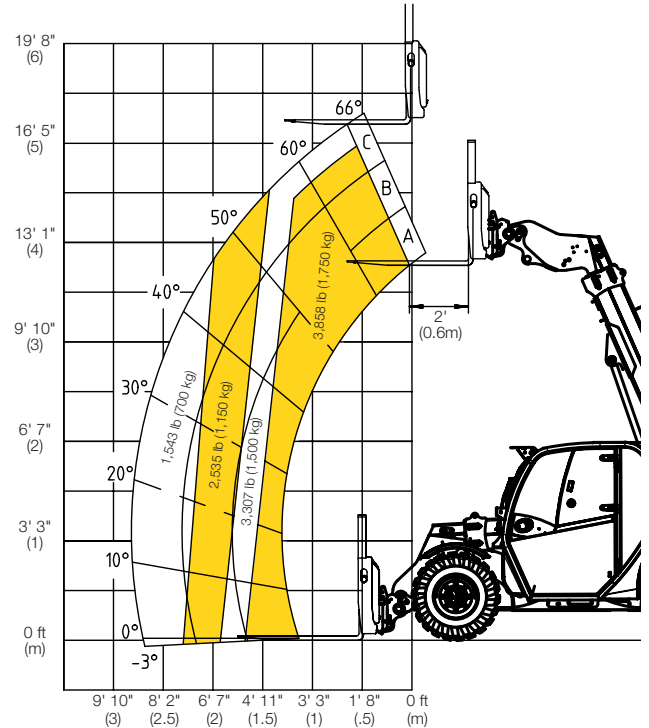

GROUND-ENGAGING TELEHANDLER

TIER 4 COMPLIANT

The story behind new emission requirements.

As part of the Clean Air Act, the U.S. Environmental Protection Agency (EPA) has adopted a comprehensive national program to reduce emissions (diesel particulate matter and nitrogen oxide) from off-road diesel engines. To meet these new emission standards, equipment manufacturers are using advanced engine and emission control technologies similar to those already used for highway diesel vehicles.



Dimensions

TH522

DIMENSIONS	UNIT	
A Total length	in (mm)	180.2 (4,576)
B Total length (without bucket)	in (mm)	147.5 (3,747)
C Axle middle to bucket pivot pin	in (mm)	22.9 (581)
D Wheelbase	in (mm)	96.4 (2,449)
E Rear overhang	in (mm)	18.6 (472)
F Height to top of cabin	in (mm)	76.8 (1,950)
H Seat top height	in (mm)	37.9 (962)
J Total working height	in (mm)	239.1 (6,074)
K Height of bucket pivot (max.)	in (mm)	215.4 (5,471)
Load-over height		
L1 Retracted telescopic arm	in (mm)	143.2 (3,638)
L Extended telescopic arm		199.1 (5,056)
Dumping height		
M1 Retracted telescopic arm	in (mm)	122.2 (3,103)
M Extended telescopic arm		178.0 (4,520)
N Operating distance for M	in (mm)	11.5 (293)
O Digging depth	in (mm)	4.4 (111)
P Total width	in (mm)	71.2 (1,808)
Q Track width	in (mm)	60.2 (1,530)
S Ground clearance	in (mm)	10.1 (256)
T Maximum radius external	in (mm)	163.5 (4,153)
U Radius at the outer edge	in (mm)	129.2 (3,281)
V Inside turning radius	in (mm)	47.0 (1,193)
X Rollback angle at max. lift height		46.5°
Y Dumping angle (max.)		34.5°
Z Rollback angle (on the ground)		41°
Operating weight (standard)	lbs (kg)	9,259 (4,200)

DEALER INSTALLED ACCESSORIES (SOLD SEPERATELY)

3" seat belt, winter convenience package, various tire options and more

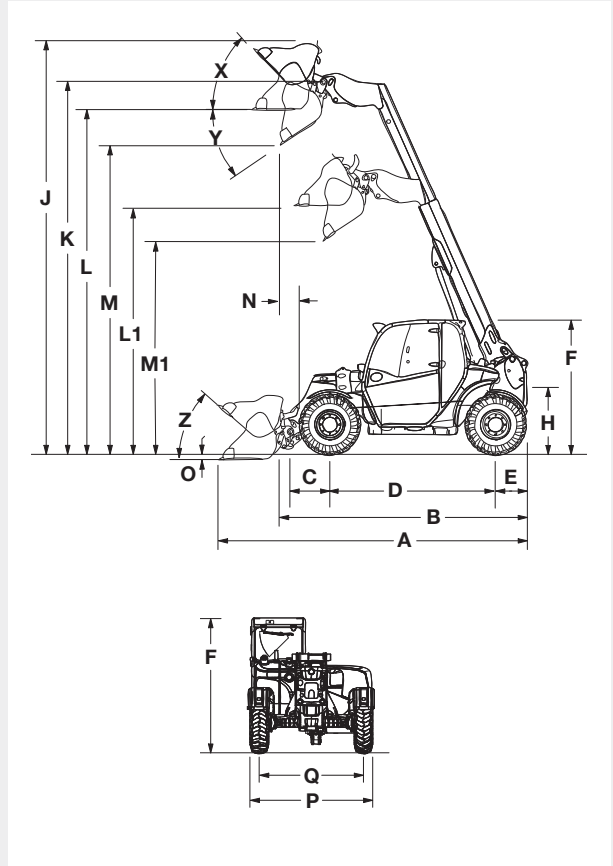

Added value.

Warranty • Finance • Parts Availability



**WACKER
NEUSON**
all it takes!

Products are only as good as the service, technical support and training behind them. Wacker Neuson and our network of dealers provide everything you need to keep running at peak performance.



**2-YEAR
WARRANTY**

Warranty: Wacker Neuson's line of compact equipment features a factory standard 24-month/2,000 hour machine warranty. Ask your dealer about our 3 year extended service protection plan. Valid in USA and Canada.



**GENUINE
PARTS**

Parts and Service: A breakdown can cost you time and money. That's why all Wacker Neuson parts are available via our U.S. distribution center and are typically shipped within 24 hours of your order. You can count on getting the parts, service, maintenance and support you need, when you need them.



ACADEMY

Technical Training and Support: Wacker Neuson Technical Academy meets the training needs of contractors, mechanics and dealer salespeople for years. Training classes are held at our production facility in Menomonee Falls, Wisconsin, just minutes from Milwaukee. Or, if you have a specific training need, we can bring the experts to your location. From in-depth industry-focused operation tips and process training to maintenance, our trained professionals can create a tailor-made program for you.



FINANCE

Flexible financing:

- Low down payments
- Competitive rates
- Cash back options
- Seasonal payment options

Wacker Neuson is a global equipment manufacturer for the construction, agriculture, oil and gas, landscape, utilities and municipal industries. Our comprehensive portfolio stands firmly on outstanding reliability, innovative technology, personal service and close customer contact. In the United States and Canada, Wacker Neuson's full line of products are sold and rented by a network of over 4,000 dealers and supported by an industry leading team of factory trained sales, application and service personnel.

www.wackerneuson.com