

DW90

Wheel Dumpers



**WACKER
NEUSON**
all it takes!



off-road unbeatable

The DW90 is a versatile bulk material mover offering articulated hydrostatic 4-wheel drive designed to carry full payloads across rough terrain, muddy conditions and steep hills. Dumpers have a smaller footprint than traditional dump trucks and can easily maneuver around confined and busy job sites, moving dirt faster and significantly improving cycle times. The DW90 can carry up to 5.6 cubic yards of dirt and is an excellent material mover partner for larger excavators.

- Operator station is easily accessible from both sides for added convenience. Dashboard displays a full range of dials/indicator lights such as fuel gauge, low fuel, warning light and parking brake light.
- Hydrostatic drive is easy and intuitive for the operator. The four wheel drive provides perfect traction on difficult terrain and articulated steering allows for a tight turning radius.
- Heavy-duty, impact resistant swivel bucket allows material to be unloaded from the front or either side, making dumping more precise and efficient. The bucket is easily operated with a simple joystick control within reach of the driver.
- Top speed of 15.5 mph/25 kmh provides for fast times and efficiency.
- Easy access for convenient maintenance. Maintenance intervals of 500 hours of operation reduces downtime.

DW90 Technical specifications

Operating data

Payload	19,842 lb
Shipping weight ROPS	12,486 lb
Shipping weight Cabin	12,927 lb
Operating weight ROPS	12,667 lb
Operating weight Cabin	13,108 lb
Skip capacity - Leveled	4.32 yd ³
Skip capacity - Heaped	5.75 yd ³
Skip capacity - Water	2.69 yd ³

Engine / Motor

Engine / Motor manufacturer	Perkins
Engine / Motor type	854F
Engine performance - ISO 3046/1	73.8 hp
Emission standards stage	3b
Displacement	207.4 in ³
Engine RPM	2500 rpm
Emissions	T4f
Traction drive	4WD, Hydrostatic drive
Travel speed	15.5 mph
Articulation angle	29 °
Pendulum angle	11 °
Turning radius	257.9 in
Gradeability	50 %
Tires	500/60-22.5
L x W x H	204 x 97 x 100 in
Steering pump	Axial piston pump
Flow rate	45.2 US gpm
Operating pressure	6,527 psi
Duty pump	Gear pump
Flow rate	18 US gpm
Operating pressure	3,408 psi
Fuel tank capacity	21.9 US gal
Hydraulic oil tank	14.5 US gal
Sound level (LwA)	102 dB(A)

DW90 Dimensions

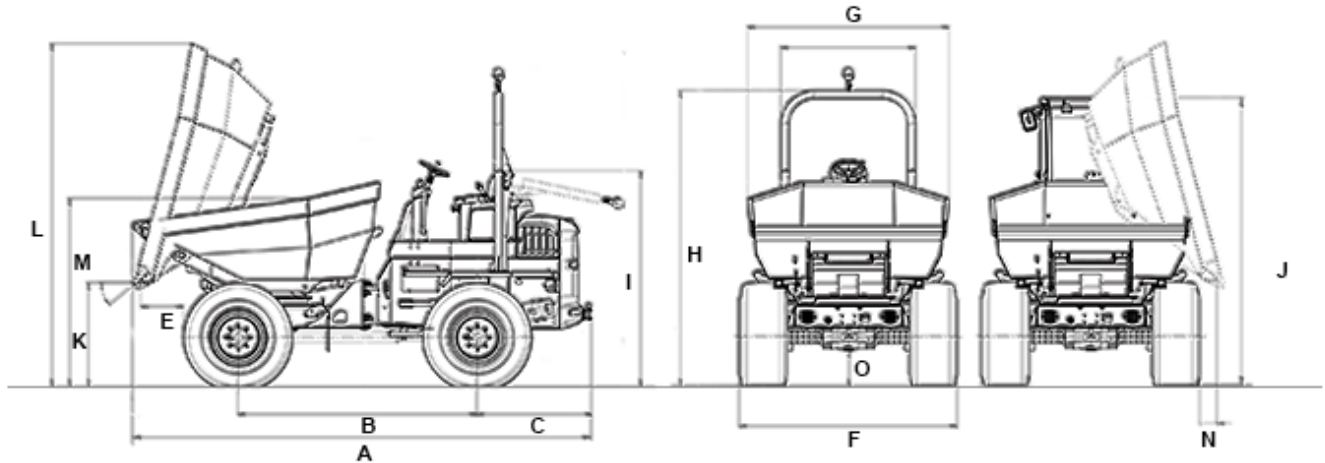

DW90 swivel tip skip

A	Overall length	204.1 in
B	Wheelbase	106.3 in
C	Rear overhang	50.9 in
E	Dumping distance	19 in
F	Width	97 in
G	Skip width	89.5 in
H	Height ROPS	132 in
I	Height ROPS tilted	100.2 in
J	Height Cab	127.7 in
K	Dump height max.	46 in
L	Skip height tilted	152.2 in
M	Skip height	83.5 in
N	Dumping distance	7.4 in
O	Ground clearance	16 in
--	Dump angle	40 °

Please note: that product availability can vary from country to country. It is possible that information / products may not be available in your country. More detailed information on engine power can be found in the operator's manual; the stated power may vary due to specific operating conditions. Subject to alterations and errors excepted. Applicable also to illustrations.

Copyright © 2020 Wacker Neuson SE.