

Mini, Compact and Wheeled Excavators



**WACKER
NEUSON**
all it takes!



Workhorses on any construction site: the mini, compact and wheeled excavators from Wacker Neuson.

1. Superior efficiency.

Our full line of excavators is designed to provide the power, maneuverability, stability and precision that enable you to get more done with less time and effort. Wacker Neuson offers reliability that reduces downtime, as well as lower fuel consumption for greater economic advantages on the job site.

2. Functionality for every task.

Wacker Neuson excavators give you the functionality you need to manage any situation. The balance of power and thoughtfully designed features, including a small emission-free model that allows for work in enclosed areas, helps you do more on the job site, no matter what the terrain.

3. Attachments to get your job done.

The right excavator is nothing without attachments that give you the flexibility to take on a variety of applications. This includes breakers and Rototilt® that go beyond the bucket. Wacker Neuson offers you those options.

Wacker Neuson—all it takes!

Featuring the industry's only 5-year warranty, Wacker Neuson's excavators are rugged and reliable, offering best-in-class breakout force for the toughest conditions. Whether you're working with dirt, stone or anything in between, Wacker Neuson has your excavation needs covered.

Excavator expertise down to the last detail.



Productivity and Performance

- **Vertical Digging System (VDS):** more productivity on a slope
- **Telescopic travel gear:** narrow for tight areas, wide for enhanced stability
- **Lifting hooks on cab roof** for easy repositioning and trailer loading
- **Compact dimensions,** enabling machines to be moved quickly to different locations

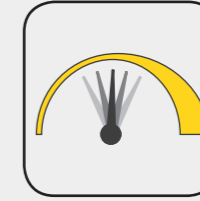

Versatility

- **Flexible range of use cases** thanks to wide selection of attachments available
- **Innovative front windshield system** for operator comfort

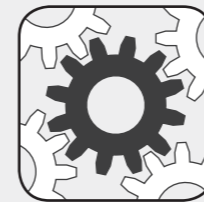

Serviceability

- **Optimal service access** saves time and money during maintenance
- **Long service life** due to the high-quality components



Operator comfort

- **Intuitive operation** using the joystick display, jog dial and keypad
- **Ergonomic cab** with custom settings
- **Visibility** of the entire work area
- **EquipCare system locates** the machine via GPS and increases the anti-theft protection (subscription required)

Excavator overview.

Mini excavators:



803

Operating weight: 2,269–2,401 lbs
> Page 04



ET16

Operating weight: 3,371–3,792 lbs
> Page 08



EZ17

Operating weight: 3,801–4,299 lbs
> Page 12



ET20

Operating weight: 4,420–5,125 lbs
> Page 16



EZ26

Operating weight: 5,668–7,191 lbs
> Page 20



EZ36

Operating weight: 8,201–10,221 lbs
> Page 24



EZ53

Operating weight: 11,539–14,178 lbs
> Page 28

Compact and wheeled excavators:



ET65

Operating weight: 13,400–15,331 lbs
> Page 32



ET90

Operating weight: 19,202–22,020 lbs
> Page 38



ET145

Operating weight: 34,284–36,012 lbs
> Page 38



EW65

Operating weight: 14,892–17,643 lbs
> Page 42



EW100

Operating weight: 21,352–24,330 lbs
> Page 46

Products are only as good as the service, technical support and training behind them. Wacker Neuson and our network of dealers provide everything you need to keep running at peak performance.
www.wackerneuson.com

The highest engine output in its class: low-consumption, 3-cylinder engine with standard auxiliary hydraulics, ideal for breaker operations

Dual power for emission-free working: simply connect the electro-hydraulic power unit and continue to work with the same performance

Foldable ROPS bar and telescopic undercarriage for optimal access to tight construction sites

Our smallest model – also works in zero emission mode: the 803 mini excavator.

	803
Shipping weight (lb)	2,055
Digging depth with standard dipper stick (in)	69
Engine output (hp)	15.4

The lift arm cylinder on the top side of the boom protects against damage



Pattern change-over requires no tools

External hydraulic oil tank keeps oil cooler without additional cooling system, enabling maximum performance in high ambient temperatures

2nd circuit auxiliary hydraulics (optional) for more flexibility in use, such as for breaker applications

The fold-over dozer blade extension always remains connected to the unit to avoid loss

dual power (optional) allows a power supply unit to be connected for zero-emission operation



Compact and versatile.

The width can be adapted as necessary with the hydraulic telescopic travel gear and the fold-over dozer blade extension: reduces track width from 33.9 inches to 27.6 inches. In the process, the elements for the dozer blade extension always remain connected to the unit. If you need to drive through a door, the the roll-over protective structure (ROPS) can also be folded down.

Expand your possibilities.

In addition to the existing diesel engine, the tracked excavators can be operated emission-free via an electro-hydraulic power unit. This is ideal for enclosed spaces or urban areas. To bring the unit to the site of application, simply attach it to the excavator's dozer blade.

dualpower



Quick relocation on site: simply hook up the power unit to the dozer blade.



Easy servicing thanks to the wide engine hood opening and easy-to-replace parts.

A powerful engine combined with a LUDV hydraulic system delivers maximum performance and precise controllability—regardless of the load being moved

Large cab with a skylight and split front windshield for the best all-round visibility

Compact dimensions allow easy transport and maneuverability in confined spaces

Big power for small spaces:
the ET16 compact mini excavator.

	ET16
Shipping weight (lb)	3,091
Digging depth with standard/long dipper stick (in)	88/95
Engine output (hp)	17.7

Simple disassembly of the cab for confined space clearance and optimal maintenance access

Optimally protected lifting arm cylinder on the top of the boom

Standard auxiliary hydraulics for simple operation of different attachments



Easy service access due to the large engine hood and removable covers

Telescopic travel gear (39–51.2 in) with fold-over dozer blade extension for a high level of flexibility in narrow construction site entrances and stability while working

Two-part front windshield for optimal ventilation in any weather.



Precise control with load-sensing hydraulics.

The load-sensing hydraulic system LUDV (load-independent flow distribution) allows for the fatigue-free control. The machine automatically adapts to the load, while the joystick movements always remain the same for the operator, to ensure precise work and optimal results.

Quick, easy and precise control with any load thanks to LUDV.



The ET16 has one of the largest cabs in its class, offering extra legroom, spacious access, heating, adjustable settings for the seat and arm rests and outstanding all-round visibility.



Easy to transport even with a small trailer, thanks to compact dimensions and a weight under 1.7 t.



Two lift points on the cab or canopy roof keep the ET16 balanced when lifting and placing.



Powerful diesel engine and optimally coordinated hydraulics (LUDV) ensure excellent excavation power and precise control

Telescopic undercarriage reduces track width for access to narrow areas

Lifting points on the roof for easy transport

Compact, powerful, maneuverable:
the EZ17 zero tail mini excavator.

	EZ17
Shipping weight (lb)	3,519
Digging depth with standard/long dipper stick (in)	92/98
Engine output (hp)	17.2

The canopy can be easily removed for low access and easy maintenance

Standard configuration has no tail overhang, ideal for work directly against walls and borders

The best stability compared to other zero tail excavators thanks to an ideal machine center of gravity

Solid steel construction, interchangeable steel bushings for durable, play-free bearing points

Optimal maneuverability in tight spaces, due to the telescopic travel gear (39–51.2) in with dozer blade extension

Optimally protected neck and lifting arm cylinder on the top side of the boom



High performance, smooth operation.

The unique combination of power and the innovative hydraulic system with LUDV (load-independent flow distribution) makes operation simpler and more efficient—even with heavy loads.

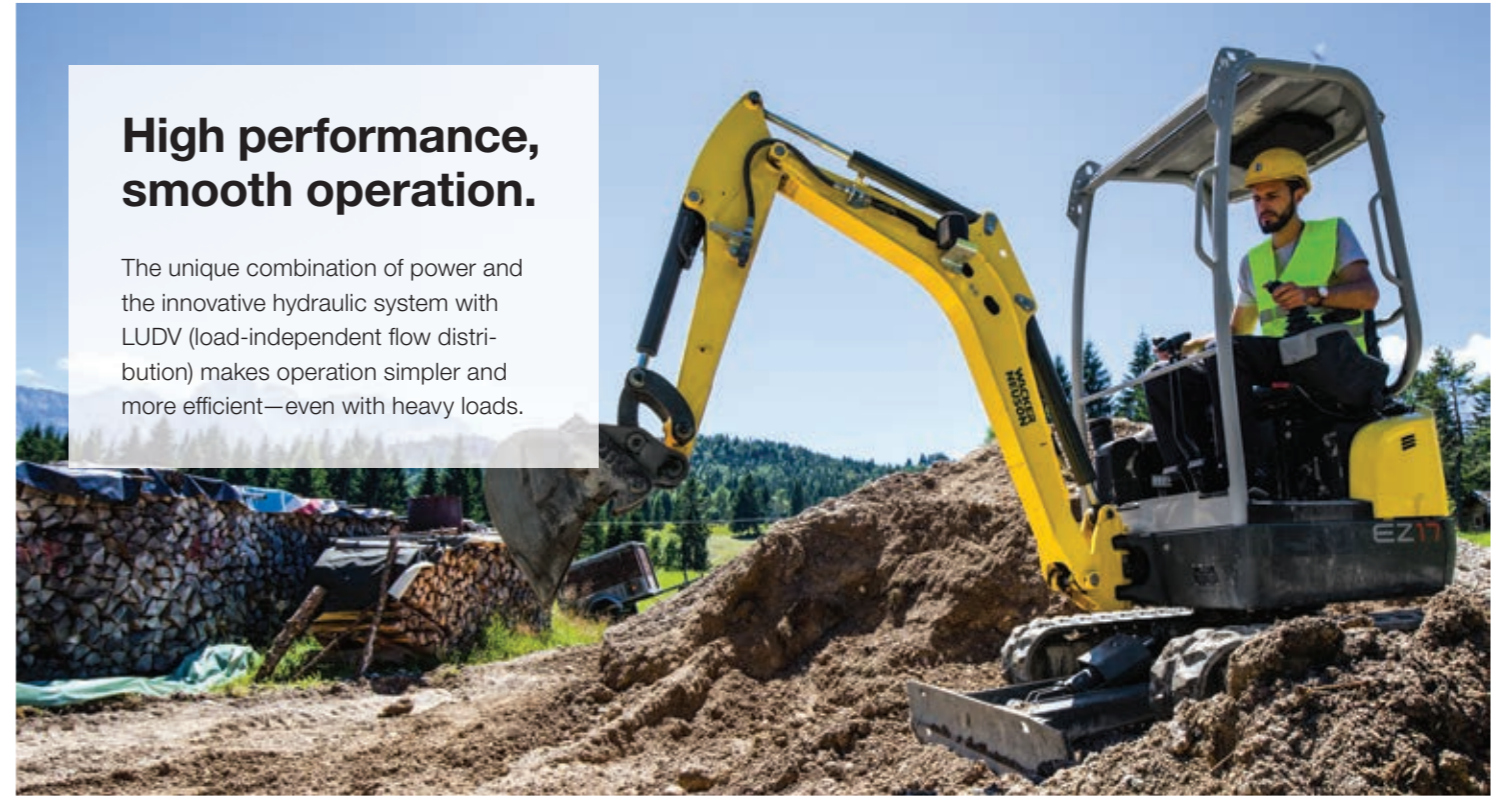

Simple serviceability.

Easily removable covers make maintenance work easy, quick and cost-effective.

The extra-large engine hood offers simple access for servicing, and the all-aluminum radiator is rugged, yet easy to clean.



Canopy with skylight: for a perfect view of the work area.



Great visibility and the flexibility to work close to walls.



The ergonomically optimized cab offers all-round visibility, plenty of legroom and headroom and a wide entry

Telescopic undercarriage reduces track width from 51 to 39 inches

The ET20 impresses with 2-ton size class performance in a foot-print comparable to a 1.5-ton machine

Total performance, best in class:
the ET20 tracked mini excavator.

	ET20
Shipping weight (lb)	4,105
Digging depth with standard/long dipper stick (in)	98/106
Engine output (hp)	17.9

Doors on both sides
(optional) for easy entry and exit on space constrained construction sites or when working directly against walls

Maneuver through low clearance heights with the cab or canopy removed

Two lifting points for easy machine placement

Individual adjustment of the seat, joystick position and armrests for ergonomic operation

Integrated counterweight reduces damage to the rear

Standard auxiliary hydraulics plumbed to mid-arm

Sturdy aluminum radiator has a long service life and is easy to clean



Windshield innovation.

No matter what the weather, Wacker Neuson excavators are ready to get the job done. The two-piece sliding front windshield on many cab models allows for water, dust and wind protection when closed, and optimal ventilation and easy communication when open. If desired, both windows can be pushed up and secured below the cab roof, eliminating the need for removal and storage prior to operation.

The front windshield system is available for:
ET16, ET20, EZ26, EZ36, EZ53,
ET65, ET90, ET145, EW65, EW100

The lower window can slide behind the upper window, if necessary.



The upper front window can be pushed under the cab roof, while the lower window is used as splash protection.



Foldable hydraulic pilot-operated travel pedals allow for easy maneuverability and fold out of the way for more foot room.



VDS: efficient on a slope.

Our innovative Vertical Digging System compensates for gradients of up to 27%. That pays off:

- Up to 25% material and time savings when excavating and filling
- Enhances operator safety with an increase in stability of up to 20%
- A good line-of-sight at all times, because the same swiveling power is ensured over 360°
- Fatigue-free working due to consistent seat position

- Required excavated material
- Excavated material without VDS

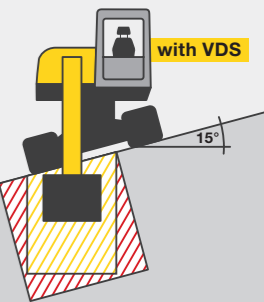

Sophisticated solutions for quick maintenance.

- ✓ Tipping seat console
- ✓ Wide engine hood opening
- ✓ Removable covers
- ✓ Optimally positioned grease fittings
- ✓ Better access reduces downtime





Compact size and generous tie-downs make transportation easy

Comfort cab with a wide entry and ergonomically adjustable operating and display elements for maximum ease of use

Quick, cost-saving maintenance access due to the large lateral engine hood and removable covers

Comfortable operation, minimal tailswing: the EZ26 mini excavator.

	EZ26
Shipping weight (lb)	5,723
Digging depth with standard/long dipper stick (in)	100/108
Engine output (hp)	20.4



Sturdy, time-tested and proven design with a long service life and high resale value

Precise operation and exact work using hydraulic, pilot-controlled pedals

Easily removable covers enhance serviceability

Minimal tail swing

Simple attachment change from the cab available with optional quick coupler

Sturdy aluminum radiator is durable and easy to clean

Compact dimensions: ideal for tight conditions and transport

Optional additional rear counterweight for higher stability and excavating power

Sloping travel gear box prevents dirt accumulation



The innovative **two-part front windshield mechanism** allows for various opening positions for the greatest possible comfort and safety in any working situation.



Work ergonomically thanks to an individually adjustable seat, joystick and armrest position, plenty of headroom and legroom and the best all-round visibility.

Solutions for quick and low-cost maintenance.

- ✓ Easy to reach: Hydraulic and engine oil filters, air filters, water separator and tank filler points
- ✓ Easy to replace: Bushings on worn bearing point
- ✓ Excellent maintenance access: Largest engine hood in its class

Easy to transport:

- Can be transported on a small trailer
- Increased range and new use cases
- Significant cost savings



Reduce the excavated volume through vertical digging with VDS.

- ▨ Required excavated material
- ▨ Excavated material without VDS

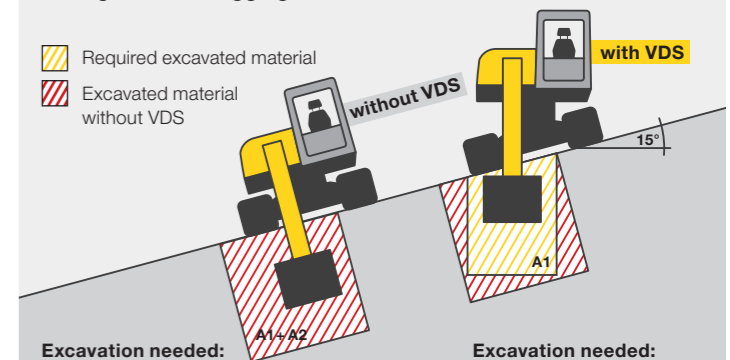

Excavation needed:
(A1 + A2) x length
(0.75 + 0.25) x 100 = **130 yd³**

Excavation needed:
A1 x length
0.75 x 100 = **98 yd³**



Optimized engine and hydraulic performance for quick cycle times

Intuitive excavator functions, including joystick, display and keypad allow operator comfort and convenience

Best-in-class dig depth and reach for long dipper allow digging along walls—get more done with less positioning

Designed for productivity:
EZ36 tracked mini excavator.

	EZ36
Shipping weight (lb)	7,372
Digging depth with standard/long dipper stick (in)	128 / 138
Engine output – POWER mode (hp)	24.4

Tiltable cab facilitates access to all important areas

Powerful air-conditioning system for operator comfort

Two-piece front windshield for different ventilation options and simple jobsite communication

Pilot-operated travel pedals for precision maneuvering

High-strength steel pins and bushings for precise operation and long service life

Debris-shedding undercarriage design

8 large tie-down lugs make securing for transport quick and easy

Dual-flange rollers improve stability for digging and loading over the side

Wide engine hood opening and removable covers reduce maintenance time and costs

Large comfortable cab with side-sliding window and individual adjustment of the seat, armrests and joystick for ergonomic fatigue-free operation.



Maximum efficiency.

From intuitive operation to ease of maintenance, our 3.5-ton excavator features an impressive range of sophisticated, detailed innovations designed to boost productivity. It also delivers powerful performance thanks to the optimized engine pump management system that accelerates workflows by up to 15%. The EZ36 zero minimal tail swing excavator is the perfect choice for contractors who often work in small spaces, such as commercial and residential landscaping, urban areas and highway construction.

Infinitely variable swiveling dozer blade with floating position for greater flexibility and efficiency.

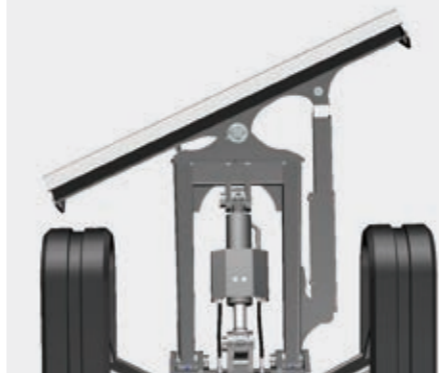

When things get tight: EZ36. Swivel without danger, even in the tightest of spaces or directly next to a wall—it's no problem with the zero tail overhang excavator EZ36.

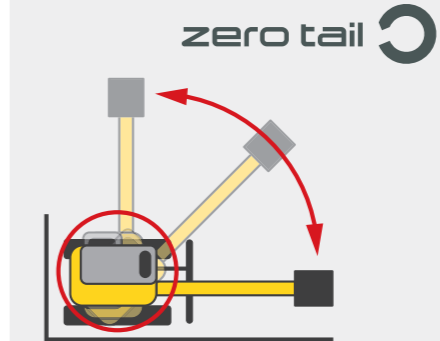

Additional gripping function: loose material can be cleared away easily with the "hydraulic thumb" (hydraulic clamp on the bucket).



Many individual options – all available:

- ✓ Hydraulic thumb
- ✓ Up to 4 additional auxiliary control circuits
- ✓ Swiveling dozer blade
- ✓ EquipCare
- ✓ Additional rear weight
- ✓ Rubber or steel tracks
- ✓ Air-conditioning system

Continuous tilting of the superstructure with VDS.

The unique vertical digging system (available option) compensates for slopes of up to 27%, making it possible to vertically excavate on a slope. Not only is it ergonomic, it saves time and excavated material.



- ▨ Required excavated material
- ▨ Excavated material without VDS

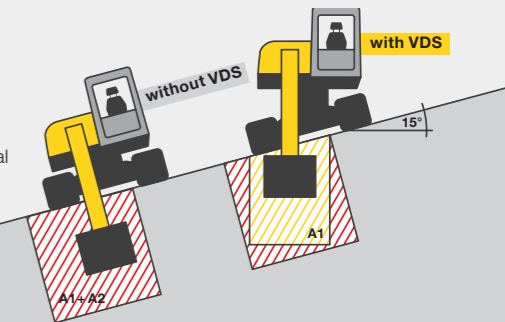

Excavation needed:
 $(A1 + A2) \times \text{length}$
 $(0.75 + 0.25) \times 100 = 130 \text{ yd}^3$

Excavation needed:
 $A1 \times \text{length}$
 $0.75 \times 100 = 98 \text{ yd}^3$

Large, comfortable cab in the zero tail class offers ample headroom, a large footwell, and an optimal view

100% zero tail: no tail overhang for optimal mobility in confined spaces

The large engine cover and tilt-able cab, combined with intuitive daily maintenance access, offer best-in-class overall serviceability

Compact and powerful:
the EZ53 zero tail mini excavator.

	EZ53
Shipping weight (lb)	10,953
Digging depth with standard/long dipper stick (in)	138 / 148
Engine output (hp)	58.9

Hydraulic, pilot-operated travel pedals for precise and responsive drive control using only your feet

Powerful turbo diesel engine—improved excavation performance and higher material handling rates with simultaneously reduced fuel consumption

Greater stability due to the optional additional rear counterweight

VDS—continuous tilting of the superstructure (optional)

Large, convenient tie-down points for easy transportation

High excavation values with the choice of two dipper stick lengths

Simple attachment change from the cab using the optional hydraulic quick coupler

Heavy-duty bearing points and interchangeable bushings for a play-free arm system

Sturdy aluminum radiator has a long life span and is easy to clean



Many individual options—all available:

- ✓ Up to 5 additional auxiliary control circuits
- ✓ EquipCare
- ✓ Additional rear counterweight
- ✓ Overload warning device
- ✓ Air-cushioned driver's seat
- ✓ Air-conditioning system
- ✓ Proportional control of the auxiliary hydraulics with flow-rate regulation (Potti)

Ventilation and communication made easy.

Both windows of the innovative front windshield system can be pushed into different positions in a few steps. This allows for ventilation and communication without having to remove windows.

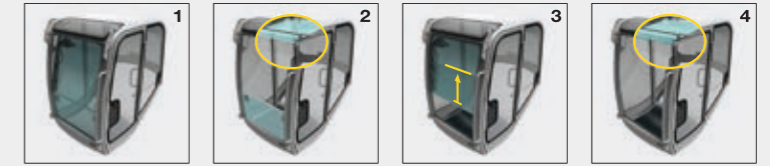

- 1** Closed-front windshield: two glass windows keep water and wind out.
- 2** The upper front windshield can be pushed under the cab roof. The lower window serves as splash protection.
- 3** The lower windshield slides behind the upper window, making it ideal for talking with colleagues on the job site.
- 4** If necessary, both windows are pushed below the cab roof where they are stored safely.

Compact with minimal tail: maneuverable in confined spaces and cost-saving during transport.



High-grade steel pins and bushings provide long wear life for optimum performance.

Work conveniently and comfortably thanks for a large cab and ergonomic design.



Easy service access due to the large lateral hood and easy-to-remove covers.



The enhanced breakout force is complemented by a three-point bucket linkage and 200-degree expanded angle of rotation for exceptional excavation productivity

The ET90 impresses with excellent engine and hydraulic performance—concentrated power that remains perfectly under control thanks to the load-sensing system

Offers unmatched visibility of the bucket and entire worksite through large windows and front and side lighting, enhancing job site safety

Power and efficiency times two: the ET65 and ET90 tracked excavators.

	ET65	ET90
Shipping weight (lb)	12,800	18,404
Digging depth with standard/long dipper stick (in)	151/162	170/182
Engine output (hp)	67.1	74.3



The most efficient drive on the market for high performances

Low tank filler point for easier refueling without climbing

Compact and maneuverable due to low-profile design

High stability due to a low center of gravity and optional additional rear counterweight

Optimized cooling package—easy to clean and with the best cooling performance in its class

8 large tie-downs make securing the machine fast and simple for safe transport

3 track types available: steel, rubber and hybrid

Ergonomic cab for operator comfort

Work lights mounted to boom and chassis for forward and lateral work area illumination

Short hydraulic hoses for less power loss and a long service life

Precise control thanks to load-sensing hydraulic system (LUDV)

3-pin linkage increases vertical wall digging depth, breakout force and range of motion

20% more breakout force delivers exceptional digging performance

Simple maintenance. Simple repair.

The high productivity of our machines is not just due to the robust technology. Most service work can be completed in a short time due to quick and easily accessible maintenance points.



Unique 3-pin kinematics.

The higher torque or the 3-pin kinematics, as well as the 200-degree expanded angle of rotation, make the ET65 and ET90 the best in their class in terms of digging power.

- Digs deeper vertically
- Enhanced breakout force
- Improved range of motion for less material loss in leading applications

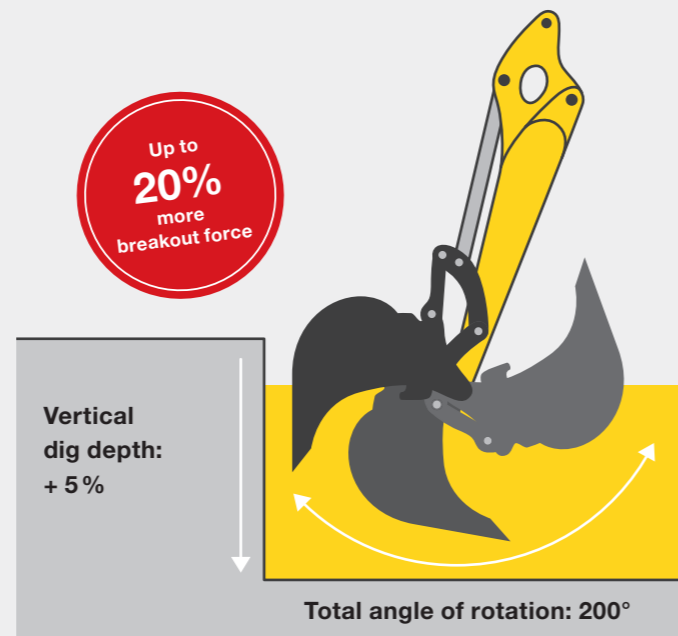

Safe entry and exit thanks to the low entry height.

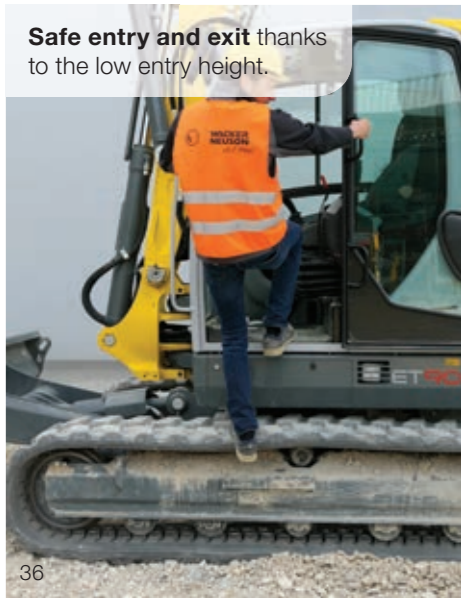

Reduced dimensions.

The compact design of the ET65 and ET90 make transport to your next job site fast and easy. And on the construction site, the machines can maneuver anywhere—even in confined spaces. You can benefit from high efficiency in all applications, whether space is ample or limited.

- Very low entry height
- Small dimensions due to the intelligent component arrangement
- Higher level of stability due to the low center of gravity

More cab comfort.

Maximum operating comfort is standard with the ET65 and ET90. In addition, we offer numerous options for customizing your excavator to your individual requirements.



Hydraulically activated coupler system.

Change an attachment in seconds using the Easy Lock hydraulic quick hitch system. With this innovative coupler, you won't even have to leave the cab—the new attachment is ready for use immediately—offering you more flexibility and productivity.

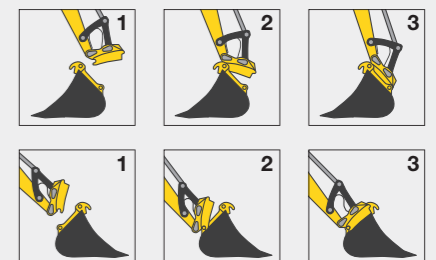



Productivity of a 14-ton excavator with the benefits of a swivel boom

Optimized engine and hydraulic package for maximum productivity

Three track options—steel, rubber and hybrid—enable the machine to operate efficiently in any application

One of the largest compacts: the ET145 tracked excavator.

	ET145
Shipping weight (lb)	32,886
Digging depth with long dipper stick (in)	216
Engine output (hp)	73.8

Lower emissions with the same performance, due to the diesel particulate filter (no SCR necessary)

2 pre-set operating modes: POWER or fuel-saving ECO mode

Intuitive operation of all excavator functions through the jog dial and display

Unique 14 ton excavator with swivel boom

6 headlights for optimal lighting of the work area

Standard dozer blade for maximum lift capacity and stability

Quiet engine for less noise pollution and easier communication

3 standard track types available, steel, rubber and hybrid, to handle a variety of surfaces

8 large tie-downs for simple, quick and safe loading

Sturdy aluminum radiator improves the cooling performance and is easy to clean

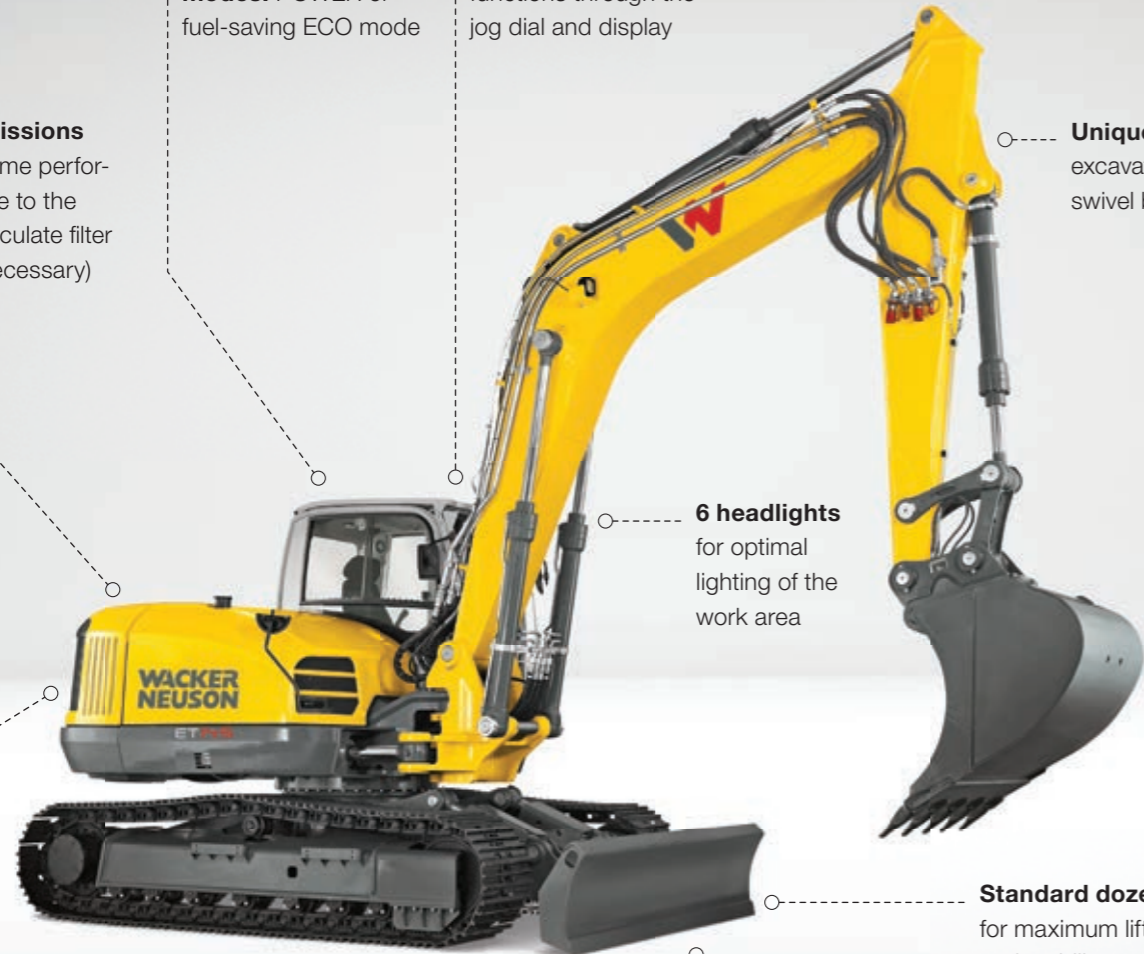

The best of both worlds.

One of the world's largest compact excavators, the ET145 combines the productivity of a large model with the advantages of a compact excavator, with its:

- High level of maneuverability
- Simple transport
- Different track versions
- High digging forces

The ET145 has a range of standard equipment to improve operator comfort and productivity. Details beginning on page 50.



The 73.7 hp engine offers excellent excavation power with low fuel consumption.



Large ergonomic comfort cab: Seat, armrests and joystick can be individually adjusted.



ET145 with swivel boom for higher productivity.

The swivel boom allows you access to an increased excavation area to the right and left. And because the machine needs to be moved less, you save valuable time.

The swivel console:

- Allows you to work along walls and trenches
- Improves the area of visibility during excavation work in trench areas
- Has a swiveling angle range of 70° left and 57° right



Full power of the engine even at low speed.

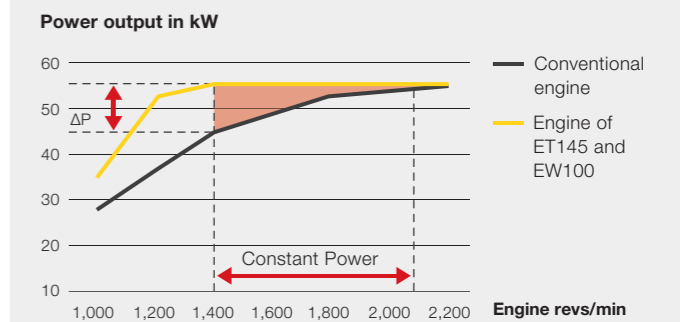

Achieve both traction and maneuverability, in all ground conditions, with tracks for different applications.



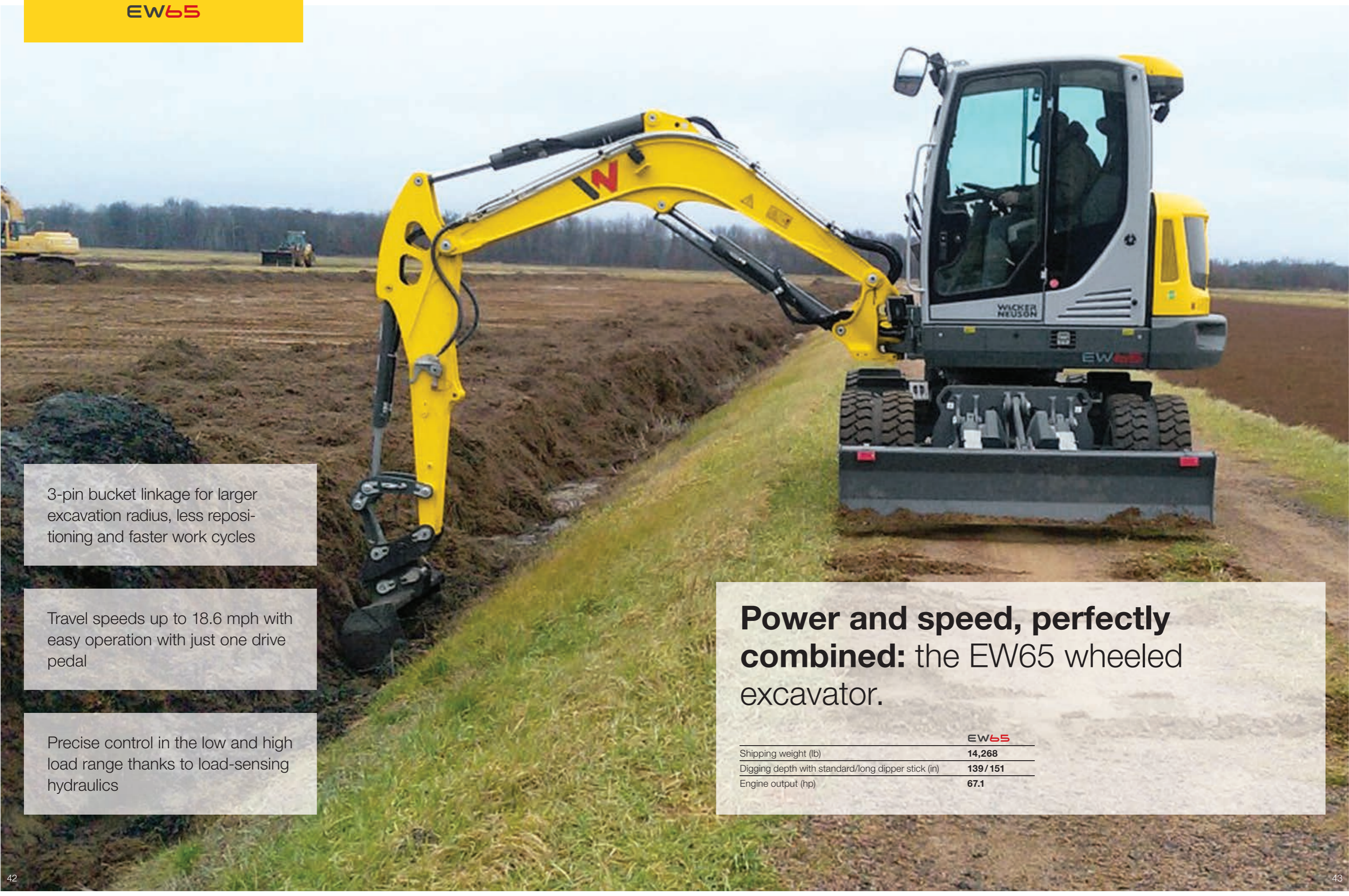

3-pin bucket linkage for larger excavation radius, less repositioning and faster work cycles

Travel speeds up to 18.6 mph with easy operation with just one drive pedal

Precise control in the low and high load range thanks to load-sensing hydraulics

Power and speed, perfectly combined: the EW65 wheeled excavator.

	EW65
Shipping weight (lb)	14,268
Digging depth with standard/long dipper stick (in)	139 / 151
Engine output (hp)	67.1

Short hydraulic hoses, thanks to the centrally positioned manifold block, offer longer service life with less power loss

Two modes of operation: POWER for max performance and ECO for fuel economy

The best thermal resistance in its class: Full performance at ambient temperature

Cruise control, ideal for municipal work such as mowing and mulching

Easy maintenance due to tiltable cab and removable chassis covers

Optimal illumination of the work area (optional: durable LEDs)

Compact design for safe entry, simple transport and safe refueling

Durable aluminum radiator with high thermal resistance

6 large tie-downs for easy tie-down and secure transport



3-pin kinematics deliver more power and range.

Advantages:

- Digs deeper vertically
- More powerful excavating
- Improved range of motion for less material loss in loading applications



Optional front stabilizers complement the standard rear dozer blade.

Powerful and precise: Thanks to load-sensing hydraulics, the power can be adjusted to the situation.



Comfortable cab: The seat, arm-rests and joystick can be adjusted individually. Operation is simple and intuitive—identical to the ET65.



Innovative windshield system.

The two-part front window allows for optimal ventilation in the cab in any weather. In addition, it makes it easier to communicate with the operator. Separate removal and storage of the window is a thing of the past.



Closed windshield—two glass windows keep water and wind out.



The upper windshield can be pushed under the cab roof. The lower pane serves as splash protection.



The lower windshield slides behind the upper one, making it ideal for talking with colleagues on the job site.



Both panes can be pushed below the cab roof for safe, secure storage.

Road travel operation is intuitive and smooth due to the fully hydraulic transmission

3 steering modes: front axle, all-wheel and crab steering

Comfortable, fatigue-free control thanks to the load-sensing hydraulic system (LUDV)

Productivity on wheels: the EW100 wheeled excavator.

	EW100
Shipping weight (lb)	20,373
Digging depth with long dipper stick (in)	169
Engine output (hp)	73.8

Ergonomic cab
with individual adjustment of seat, joystick position and armrests

Cruise control,
ideal for municipal work such as mowing and mulching

Optimally positioned valve bloc:
hydraulic hoses are shorter and wear less, maximizing efficiency

Intuitive operating concept: simple control by joystick, display, jog dial and keypad

Sturdy aluminum radiator that is easy to clean

Optimal ventilation and communication due to flexible windshield system

Stability as a standard: Rear dozer blade and independently operated front stabilizers provide maximum stability

More than an excavator.

Mobile excavators move quickly on job sites in a way that tracked excavators can't.



Optimized engine performance.

With its constant power engine, the excavation performance of the EW100 remains consistently high, independent of the engine speed. That means:

- Full power even at low rpm
- Less fuel consumption
- Lower maintenance costs due to no required SCR (selective catalytic reduction)



Large tiltable cab.

Optimal access to all-important service areas: The cab can be tilted to the side roughly 60° and the chassis covers can be removed in a few simple steps, making service and maintenance easier.



Three steering modes.

The EW100 has three steering modes for various applications on the construction site, as well as for road travel. The steering method can be easily changed using a rocker switch.



Front wheel steering for fast driving on the road.



All-wheel steering for a small turning radius.



Crab steering for parallel travel along buildings.

Editions

Your excavation needs vary based on the job site. That's why Wacker Neuson offers a wide selection of excavator features and editions. Our dealers can help you find the right machine for the task.

	803/ 803 dualpower	ET16	EZ17	ET20	EZ26	EZ36	EZ53	ET65	ET90	ET145	EW65	EW100
OPERATORS STATION												
Enclosed cab	-	○	-	○	○	○	○	●	●	●	●	●
Air conditioning (cab only)	-	-	-	-	-	●	●	●	●	●	●	●
Canopy	-	○	●	○	○	○	○	-	-	-	-	-
Foldable ROPS	●	-	-	-	-	-	-	-	-	-	-	-
Exterior mirror package	-	○	-	-	○	○	○	●	●	●	●	●
HYDRAULICS												
Hydraulic thumb bracket (long arm editions)	-	-	-	-	●	●	●	●	●	●	●	●
Changeover valve ISO-SAE	●	●	●	●	●	●	●	●	●	●	●	●
Bi-directional auxiliary hydraulics	●	●	●	●	●	●	●	●	●	●	●	●
Flat-faced auxiliary coupler	●	●	●	●	●	●	●	●	●	●	●	●
Direct to tank return line for one-way attachments	●	●	●	●	●	●	●	●	●	●	●	●
Hydraulic quick coupler	-	-	-	-	-	○	○	●	●	●	●	○
Hydraulic thumb	-	-	-	-	○	○	○	○	○	○	○	○
Hydraulic angle dozer blade (not compatible with VDS)	-	-	-	-	-	○	-	-	-	-	-	-
MISCELLANEOUS												
VDS (Vertical Digging System)	-	-	-	-	○	○	○	-	-	-	-	-
Telescopic travel gear	●	●	●	●	-	-	-	-	-	-	-	-
Counterweight (long dipper machines)	●	●	●	●	●	●	●	●	●	●	●	●
Counterweight (standard dipper machines)	○	○	○	○	○	○	○	○	○	○	○	○
Travel alarm	●	●	●	●	●	●	●	●	●	●	●	●
Work light mounted to the boom	●	●	●	●	●	●	●	●	●	●	●	●
Additional work lighting	-	-	-	-	○	●	○	●	●	●	●	●
Steel tracks	-	-	-	-	-	-	○	○	○	○	-	-
Hybrid tracks	-	-	-	-	-	-	-	○	○	○	-	-
Dual tires	-	-	-	-	-	-	-	-	-	-	●	●

● Standard feature ○ Option - Not applicable

Lifting force tables—standard dipper stick

BO3/BO3 dualpower

A	MAX															98,4 in						78,7 in						59,1 in						39,4 in					
	C				D				C				D				C				D				C				D										
	Blade up		Blade down		Telescopic travel gear extended		Blade up		Blade down		Telescopic travel gear extended		Blade up		Blade down		Telescopic travel gear extended		Blade up		Blade down		Telescopic travel gear extended		Blade up		Blade down		Telescopic travel gear extended										
B	kg	lbs	kg	lbs	kg	lbs	kg	lbs	kg	lbs	kg	lbs	kg	lbs	kg	lbs	kg	lbs	kg	lbs	kg	lbs	kg	lbs	kg	lbs	kg	lbs	kg	lbs									
	78,7 in	205	452*	205	452*	167	368	256	564	—	—	335	739*	318	701*	203	448*	318	701*	—	—	—	—	—	—	—	—	—	—	—	—	—							
59,1 in	163	359	191	421*	126	278	244	538	—	—	337	743	319	703	189	417*	439	968	438	966	—	—	567	1,250*	—	—	—	—	—	—	—								
39,4 in	142	313	177	390*	109	240	232	512	185	408	324	714	296	653	217	478*	416	917	400	882	247	545*	569	1,255	600	1,323	—	—	883	1,947									
19,7 in	135	298	166	366*	103	227	—	—	184	406	—	—	293	646	247	545*	412	908	397	875	366	807*	566	1,248	606	1,336	—	—	889	1,960									
0 in	137	302	155	342*	104	229	—	—	171	377	—	—	—	—	247	545*	—	—	406	895	379	836*	575	1,268*	619	1,365	678	1,495*	851	1,876*									
-19,7 in	146	322*	146	322*	115	254	—	—	—	—	—	—	293	646	215	474*	412	908	397	875	325	717*	566	1,248	606	1,336	561	1,237*	889	1,960									
-39,4 in	138	304*	138	304*	138	304*	—	—	—	—	—	—	—	—	149	329*	—	—	406	895	343	756*	575	1,268*	619	1,365	418	922*	851	1,876*									

EZ16 cabin telescopic undercarriage, standard dipper stick

A	MAX															118,1 in						78,7 in						39,4 in					
	C				D				C				D				C				D				C				D				
	Blade up		Blade down		Telescopic travel gear extended		Blade up		Blade down		Telescopic travel gear extended		Blade up		Blade down		Telescopic travel gear extended		Blade up		Blade down		Telescopic travel gear extended		Blade up		Blade down		Telescopic travel gear extended				
B	kg	lbs	kg	lbs	kg	lbs	kg	lbs	kg	lbs	kg	lbs	kg	lbs	kg	lbs	kg	lbs	kg	lbs	kg	lbs	kg	lbs	kg	lbs	kg	lbs	kg	lbs			
	59,1 in	222	490	365	805*	293	646	225	496	366	807*	296	653	397	875*	397	875*	397	875*	—	—	—	—	—	—	—	—	—	—	—	—		
39,4 in	205	452	350	772*	272	600	222	490	372	820*	293	646	403	889	561	1,237*	531	1,171	—	—	—	—	—	—	—	—	—	—	—	—			
19,7 in	199	439	336	741*	265	584	217	478	373	822*	289	637	384	847	658	1,451*	512	1,129	—	—	—	—	—	—	—	—	—	—	—	—			
0 in	203	448	324	714*	271	598	214	472	353	778*	286	631	373	822	652	1,438*	500	1,103	—	—	—	—	—	—	—	—	—	—	—	—			
-19,7 in	219	483	315	695*	292	644	—	—	—	—	—	—	370	816	588	1,297*	497	1,096	1,226	2,703	1,480	3,263*	1,480	3,263*	—	—	—	—	—	—			
-39,4 in	256	564	309	681*	309	681*	—	—	—	—	—	—	372	820	492	1,085*	492	1,085	1,231	2,714	1,336	2,946*	1,336	2,946*	—	—	—	—	—	—			
-59,1 in	313	690*	313	690*	313	690*	—	—	—	—	—	—	344	759*	344	759*	344	759*	—	—	—	—	—	—	—	—	—	—	—	—			

EZ17 canopy and telescopic undercarriage, standard dipper stick, counterweight

A	MAX															118,1 in						98,4 in						78,7 in						59,1 in					
	C				D				C				D				C				D				C				D										
	Blade up		Blade down		Telescopic travel gear extended		Blade up		Blade down		Telescopic travel gear extended		Blade up		Blade down		Telescopic travel gear extended		Blade up		Blade down		Telescopic travel gear extended		Blade up		Blade down		Telescopic travel gear extended										
B	kg	lbs	kg	lbs	kg	lbs	kg	lbs	kg	lbs	kg	lbs	kg	lbs	kg	lbs	kg	lbs	kg	lbs	kg	lbs	kg	lbs	kg	lbs	kg	lbs	kg	lbs									
	98,4 in	299	659	474	1,045*	326	719	—	—	—	—	—	—	303	668	469	1,034*	330	728	—	—	—	—	—	—	—	—	—	—	—	—	—							
78,7 in	228	503	468	1,032*	251	553	—	—	—	—	—	—	305	673	431	950*	332	732	—	—	—	—	—	—	—	—	—	—	—	—	—								
39,4 in	179	395	435	959*	199	439	215	474	491	1,083*	238	525	287	633	591	1,303*	315	695	408	900	781	1,722*	442	975	—	—	—	—	—	—	—								
0 in	175	386	404	891*	196	432	204	450	493	1,087*	227	501	268	591	653	1,440*	296	653	374	825	916	2,020*	408	900	—	—	—	—	—	—	—								
-39,4 in	217	478	384	847*	241	531	—	—	—	—	—	—	265	584	511	1,127*	293	646	373	822	705	1,555*	408	900	609	1,343	1,034	2,280*	653	1,440									
-59,1 in	289	637	386	851*	318	701	—	—	—	—	—	—	—	—	—	—	—	—	381	840	540	1,191*	416	917	621	1,369	811	1,788*	664	1,464									

EZ20 cabin and telescopic undercarriage, standard dipper stick

A	MAX															137,8 in						118,1 in						98,4 in						78,7 in					
	C				D				C				D				C				D				C				D										
	Blade up		Blade down		Telescopic travel gear extended		Blade up		Blade down		Telescopic travel gear extended		Blade up		Blade down		Telescopic travel gear extended		Blade up		Blade down		Telescopic travel gear extended		Blade up		Blade down		Telescopic travel gear extended										
B	kg	lbs	kg	lbs	kg	lbs	kg	lbs	kg	lbs	kg	lbs	kg	lbs	kg	lbs	kg	lbs	kg	lbs	kg	lbs	kg	lbs	kg	lbs	kg	lbs	kg	lbs									
	98,4 in	322	710	382	842*	355	783	—	—	—	—	—	—	316	697	385	849*	349	770	355	783*	355	783*	355	783*	—	—	—	—	—	—	—							
78,7 in	275	606	383	845*	304	670	—	—	—	—	—	—	316	697	378	833*	348	767	384	847*	10	21*	384	847*	—	—	—	—	—	—	—								
39,4 in	237	523	397	875*	263	580	240	529	399	880*	266	587	301	664	445	981*	333	734	389	858	532	1,173*	432	953	531	1,171	722	1,592*	593	1,308									
0 in	241	531	420	926*	267	589	—	—	—	—	—	—	287	633	501	1,105*	319	703	366	807	639	1,409*	408	900	496	1,094	887	1,956*	557	1,228									
-39,4 in	299	659	443	977*	332	732	—	—	—	—	—	—	—	—	—	—	—	364	803	578	1,274*	407	897	497	1,096	778	1,715*	558	1,230										
-59,1 in	391	862	442	975*	435	959	—	—	—	—	—	—	—	—	—	—	—	—	508	1,120	608	1,341*	569	1,255	—	—	—	—	—	—									

EZ26 cabin, standard dipper stick, counterweight

A	MAX															137,8 in						118,1 in						98,4 in						78,7 in					
	C				D				C				D				C				D				C				D										
	Blade up		Blade down		Telescopic travel gear extended		Blade up		Blade down		Telescopic travel gear extended		Blade up		Blade down		Telescopic travel gear extended		Blade up		Blade down		Telescopic travel gear extended		Blade up		Blade down		Telescopic travel gear extended										
B	kg	lbs	kg	lbs	kg	lbs	kg	lbs	kg	lbs	kg	lbs	kg	lbs	kg	lbs	kg	lbs	kg	lbs	kg	lbs	kg	lbs	kg	lbs	kg	lbs	kg	lbs									
	118,1 in	487	1,074	521	1,149*	434	957	—	—	—	—	—	—	505	1,114*	505	1,114*	476	1,050*	—	—	—	—	—	—	—	—	—	—	—	—								
78,7 in	356	785	502	1,107*	317	699	404	891	505	1,114*	360	794	522	1,151	538	1,186*	464	1,023	603	1,330*	603	1,330*	603	1,330*	—	—	—	—	—	—	—								
39,4 in	319	703	507	1,118*	284	626	385	849	569	1,255*	342	754	486	1,072	681	1,502*	430	948	638	1,407	895	1,973*	558	1,230	—	—	—	—	—	—	—								
0 in	331	730	517	1,140*	294	648	371	818	597	1,316*	328	723	462	1,019	750	1,654*	407	897	604	1,332	992	2,187*	526	1,160	865	1,907	1,398	3,083*	738	1,627									
-39,4 in	417	919	512	1,129*	369	814	—	—	—	—	—	—	465	1,025	622	1,372*	409	902	609	1,343	826	1,821*	530	1,169	879	1,938	1,105	2,437*	751	1,656									

EZ36 cabin, standard dipper stick, counterweight

A	MAX															157,5 in						118,1 in						78,7 in					
	C				D				C				D				C																

Lifting force tables—long dipper stick

EZ16 cabin telescopic undercarriage, long dipper stick

A	MAX																							
	118,1 in						78,7 in						39,4 in											
	C			D			C			D			C			D								
	Blade up		Blade down	Telescopic travel gear extended		Blade up		Blade down	Telescopic travel gear extended		Blade up		Blade down	Telescopic travel gear extended		Blade up		Blade down	Telescopic travel gear extended					
	kg	lbs	kg	lbs	kg	lbs	kg	lbs	kg	lbs	kg	lbs	kg	lbs	kg	lbs	kg	lbs	kg	lbs				
	59,1 in	203	448	336	741*	270	595	225	496	344	759*	297	655	315	695*	315	695*	315	695*	315	695*	315	695*	
39,4 in	189	417	325	717*	252	556	220	485	360	794*	292	644	406	895	500	1,103*	500	1,103*	500	1,103*	500	1,103*		
19,7 in	184	406	314	692*	246	542	214	474	370	816*	287	633	385	849	635	1,400*	513	1,131	—	—	—	—	—	
0 in	187	412	304	670*	251	553	211	465	360	794*	283	624	371	818	657	1,449*	499	1,100	—	—	—	—	—	
-19,7 in	199	439	296	653*	268	591	209	461	323	712*	281	620	366	807	608	1,341*	493	1,087	1,203	2,653	1,708	3,766*	1,708	3,766*
-39,4 in	229	505	291	642*	291	642*	—	—	—	—	—	—	366	807	522	1,151*	493	1,087	1,212	2,672	1,504	3,316*	1,504	3,316*
-59,1 in	294	648*	294	648*	294	648*	—	—	—	—	—	—	373	822	397	875*	397	875*	—	—	—	—	—	—

EZ17 canopy and telescopic undercarriage, long dipper stick, counterweight

A	MAX																							
	118,1 in						98,4 in						78,7 in						59,1 in					
	C			D			C			D			C			D			C			D		
	Blade up		Blade down	Telescopic travel gear extended		Blade up		Blade down	Telescopic travel gear extended		Blade up		Blade down	Telescopic travel gear extended		Blade up		Blade down	Telescopic travel gear extended		Blade up		Blade down	Telescopic travel gear extended
	kg	lbs	kg	lbs	kg	lbs	kg	lbs	kg	lbs	kg	lbs	kg	lbs	kg	lbs	kg	lbs	kg	lbs	kg	lbs	kg	lbs
	98,4 in	260	573	434	957*	285	628	—	—	—	—	307	677	375	827*	334	736	—	—	—	—	—	—	—
78,7 in	206	454	431	950*	228	503	222	490	423	933	245	540	307	677	362	798*	334	736	—	—	—	—	—	—
39,4 in	165	364	405	893*	184	406	214	472	471	1039	237	523	288	635	549	1211*	316	697	413	911	686	1513*	447	986
0 in	161	355	380	838*	181	399	202	445	497	1096	225	496	265	584	655	1444*	293	646	371	818	929	2048*	406	895
-39,4 in	194	428	364	803*	217	478	200	441	385	849	223	492	260	573	540	1191*	288	635	366	807	745	1643*	401	884
-59,1 in	247	545	365	805*	273	602	—	—	—	—	265	584	413	911*	293	646	373	822	596	1314*	408	900	609	1343

EZ20 cabin and telescopic undercarriage, long dipper stick

A	MAX																							
	137,8 in						118,1 in						98,4 in						78,7 in					
	C			D			C			D			C			D			C			D		
	Blade up		Blade down	Telescopic travel gear extended		Blade up		Blade down	Telescopic travel gear extended		Blade up		Blade down	Telescopic travel gear extended		Blade up		Blade down	Telescopic travel gear extended		Blade up		Blade down	Telescopic travel gear extended
	kg	lbs	kg	lbs	kg	lbs	kg	lbs	kg	lbs	kg	lbs	kg	lbs	kg	lbs	kg	lbs	kg	lbs	kg	lbs	kg	lbs
	98,4 in	283	624	341	752*	313	690	—	—	—	—	317	699	326	719*	326	719*	—	—	—	—	—	—	—
78,7 in	246	542	345	761*	272	600	—	—	—	—	314	692	334	736*	334	736*	330	728*	330	728*	330	728*	—	—
39,4 in	214	472	360	794*	238	525	234	516	370	816*	260	573	296	653	411	906*	328	723	386	851	485	1069*	429	946
0 in	215	474	382	842*	240	529	225	496	400	882*	251	553	279	615	484	1067*	311	686	358	789	616	1358*	400	882
-39,4 in	260	573	407	897*	289	637	—	—	—	—	276	609	451	994*	308	679	352	776	596	1314*	394	869	482	1063
-59,1 in	323	712	416	917*	360	794	—	—	—	—	—	—	—	—	—	359	792	492	1085*	401	884	491	1083	

EZ26 cabin, long dipper stick, counterweight

A	MAX																							
	137,8 in						118,1 in						98,4 in						78,7 in					
	C			D			C			D			C			D			C			D		
	Blade up		Blade down	Telescopic travel gear extended		Blade up		Blade down	Telescopic travel gear extended		Blade up		Blade down	Telescopic travel gear extended		Blade up		Blade down	Telescopic travel gear extended		Blade up		Blade down	Telescopic travel gear extended
	kg	lbs	kg	lbs	kg	lbs	kg	lbs	kg	lbs	kg	lbs	kg	lbs	kg	lbs	kg	lbs	kg	lbs	kg	lbs	kg	lbs
	118,1 in	428	944	470	1,036*	381	840	—	—	—	—	434	957*	434	957*	434	957*	—	—	—	—	—	—	—
78,7 in	324	714	459	1,012*	288	635	405	893	462	1,019*	361	796	486	1,072*	486	1,072*	466	1,028	—	—	—	—	—	—
39,4 in	293	646	466	1,028*	260	573	383	845	541	1,193*	340	750	486	1,072	641	1,413*	429	946	643	1,418	832	1,835*	563	1,241
0 in	301	664	478	1,054*	267	589	365	805	591	1,303*	322	710	457	1,008	739	1,629*	402	886	599	1,321	985	2,172*	521	1,149
-39,4 in	368	811	482	1,063*	325	717	—	—	—	—	454	1,001	664	1,464*	398	878	597	1,316	875	1,929*	519	1,144	863	1,903

EZ36 cabin, long dipper stick, counterweight

A	MAX																							
	157,5 in						118,1 in						78,7 in											
	C			D			C			D			C			D								
	Blade up		Blade down	Telescopic travel gear extended		Blade up		Blade down	Telescopic travel gear extended		Blade up		Blade down	Telescopic travel gear extended		Blade up		Blade down	Telescopic travel gear extended					
	kg	lbs	kg	lbs	kg	lbs	kg	lbs	kg	lbs	kg	lbs	kg	lbs	kg	lbs	kg	lbs	kg	lbs				
	157,5 in	651	1,435*	651	1,435*	651	1,435*	—	—	—	—	—	—	—	—	—	—	—	—	—	—	—	—	—
118,1 in	505	1,114	660	1,455*	499	1,100	594	1,310	614	1,354*	587	1,294	—	—	—	—	—	—	—	—	—	—	—	
78,7 in	428	944	684	1,508*	423	933	579	1,277	681	1,502*	572	1,261	728	1,605*	728	1,605*	728	1,605*	—	—	—	—	—	—
39,4 in	401	884	716	1,579*	395	871	552	1,217	818	1,804*	545	1,202	842	1,857	1,097	2,419*	833	1,837	1,538	3,391	2,260	4,983*	1,530	3,374
0 in	407	897	755	1,665*	401	884	528	1,164	933	2,057*	521	1,149	791	1,744	1,361	3,001*	783	1,727	1,467	3,235	2,600	5,733*	1,457	3,213
-39,4 in	456	1,005	798	1,760*	449	990	520	1,147	943	2,079*	513	1,131	776	1,711	1,395	3,076*	767	1,691	1,470	3,241	2,412	5,318*	1,461	3,222
-78,7 in	608	1,341	827	1,824*	600	1,323	—	—	—	—	790	1,742	1,155	2,547*	782	1,724	1,504	3,316	1,889	4,165*	1,495	3,296	—	—

EZ53 cabin, long dipper stick

A	MAX																	
	157,5 in						118,1 in						78,7 in					
	C			D			C			D			C			D		
	Blade down		Telescopic travel gear extended		Blade down		Telescopic travel gear extended		Blade down		Telescopic travel gear extended		Blade down		Telescopic travel gear extended			
	kg	lbs	kg	lbs	kg	lbs	kg	lbs	kg	lbs	kg	lbs	kg	lbs	kg	lbs	kg	lbs
	157,5 in	920	2,029*	660	1,455	855	1,885*	785	1,731	—	—	—	—	—	—	—	—	—
118,1 in	915	2,018*	500	1,103	865	1,907*	780	1,720	—	—	—	—	—	—	—	—	—	—
78,7 in	935	2,062*	425	937	1,050	2,315*	730	1,610	1,315	2,900*	1,170	2,580	—	—	—	—	—	—
39,4 in	970	2,139*	395	871	1,310	2,889*	665	1,466	2,025	4,465*	1,010	2,227	—	—	—	—	—	—
0 in	1,015	2,238*	400	882	1,495	3,296*	610	1,345	2,385	5,259*	915	2,018	—	—	—	—	—	—
-39,4 in	1,065	2,348*	440	970	1,515	3,341*	590	1,301	2,350	5,182*	890	1,962	4,570	10,077*	1,750	3,859	—	—
-78,7 in	1,110	2,448*	565	1,246	1,250	2,756*	600	1,323	1,970	4,344*	910	2,007	3,590	7,916*	1,805	3,980	—	—

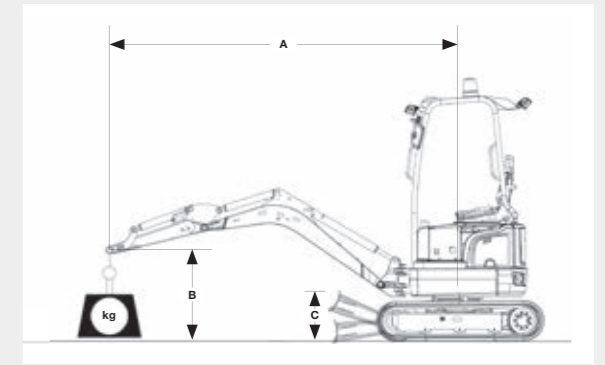

ET65 long dipper stick, counterweight, rubber track

Dimensions

		803	803 dualpower	ET16	EZ17	ET20	EZ26	EZ36	EZ53	ET65	ET90	ET145	EW65	EW100	
DIMENSIONS		UNIT													
A	Height	in (mm)	89 (2,261)	89 (2,261)	91 (2,317)	93 (2,362)	90.4 (2,295)	95 (2,414)	98/101 (2,491/2,573*)	101.3 (2,572)	97.6 (2,478)	100.9 (2,562)	109.7 (2,786)	108.5 (2,755)	117.7 (2,989)
B1	Width undercarriage retracted (tracked/tires)	in (mm)	27.6 (700)	27.6 (700)	39 (990)	39 (990)	39 (990)	61.8 (1,570)	68.9 (1,750)	78.3 (1,990)	76.8 (1,950)	88.6 (2,250)	98.0 (2,490)	82.2 (2,088)	96.6 (2,454)
B2	Width undercarriage extended (only telescopic transport gear)	in (mm)	33.9 (860)	33.9 (860)	51.2 (1,300)	51.2 (1,300)	51.2 (1,300)	61.9 (1,571)	69 (1,750)	-	-	-	-	-	-
D1	Max. digging depth (standard dipper stick)	in (mm)	69.4 (1,763)	69.4 (1,763)	88.3 (2,242)	91.6 (2,326)	97.8 (2,483)	100.2 (2,544)	127.8 (3,247)	137.8 (3,501)	150.6 (3,826)	170.3 (4,325)	-	139.0 (3,531)	-
D2	Max. digging depth (long dipper stick)	in (mm)	-	-	95 (2,413)	97.9 (2,486)	105.6 (2,683)	108.1 (2,744)	137.6/134.7 (3,497/3,422**)	147.7 (3,751)	162.4 (4,126)	182.1 (4,625)	215.8 (5,481)	150.8 (3,831)	169.2 (4,298)
E1	Max. vertical digging depth (long dipper stick)	in (mm)	52 (1,320)	52 (1,320)	64.6 (1,642)	67.4 (1,713)	65.4 (1,660)	77.2 (1,962)	83.6 (2,123)	105.0 (2,667)	93.8 (2,383)	125.7 (3,192)	-	82.2 (2,088)	-
E2	Max. vertical digging depth (standard dipper stick)	in (mm)	-	-	70.9 (1,802)	73.3 (1,863)	72.6 (1,845)	84.7 (2,152)	92.9 (2,360)	114.4 (2,906)	104.6 (2,656)	136.8 (3,474)	139.8 (3,550)	93.0 (2,361)	143.6 (3,648)
G1	Max. dumping height (standard dipper stick)	in (mm)	79.2 (2,012)	79.2 (2,012)	93.3 (2,371)	95.9 (2,436)	106.8 (2,713)	111.8 (2,840)	131.3 (3,336)	144.8 (3,678)	154.0 (3,912)	199.4 (5,066)	-	165.6 (4,207)	-
G2	Max. dumping height (long dipper stick)	in (mm)	-	-	98.1 (2,493)	100.4 (2,550)	111.7 (2,836)	116.9 (2,970)	137.4/140 (3,489/3,564**)	151.1 (3,837)	161.2 (4,094)	207.6 (5,272)	234.1 (5,945)	172.8 (4,389)	210.5 (5,346)
H1	Max. reach at ground level (standard dipper stick)	in (mm)	119.2 (3,028)	119.2 (3,028)	143.6 (3,648)	151.5 (3,848)	158.7 (4,031)	176.4 (4,481)	212.2 (5,391)	230.7 (5,860)	240.0 (6,097)	282.6 (7,179)	-	237.2 (6,024)	-
H2	Max. reach at ground level (long dipper stick)	in (mm)	-	-	150 (3,811)	157.6 (4,002)	166.3 (4,225)	184.3 (4,681)	222 (5,641)	240.3 (6,104)	251.5 (6,387)	294.3 (7,474)	335.7 (8,527)	248.7 (6,318)	299.6 (7,611)
K1	Max. digging radius (standard dipper stick)	in (mm)	121.7 (3,090)	121.7 (3,090)	145.7 (3,700)	153.5 (3,899)	162.6 (4,129)	181.6 (4,613)	208.6 (5,298)	235.7 (5,987)	244.9 (6,220)	288.6 (7,331)	-	244.9 (6,220)	-
K2	Max. digging radius (long dipper stick)	in (mm)	-	-	152 (3,861)	159.4 (4,050)	170 (4,317)	189.2 (4,805)	219.8 (5,582)	245.1 (6,225)	256.1 (6,504)	300 (7,620)	343.6 (8,727)	256.1 (6,504)	308.0 (7,822)
P	Scraping depth below ground	in (mm)	7 (178)	7 (178)	10.4 (264)	15.4 (390)	11.7 (297)	16.5 (419)	19.9 (505)	17.8 (453)	16.8 (427)	20.4 (518)	20.9 (531)	11.9 (301)	-
R1	Min. tail swing radius	in (mm)	29.4 (747)	29.4 (747)	42.3 (1,075)	26.0 (660)	46 (1,169)	29.9 (759)	37 (933)	39.2 (995)	53.7 (1,363)	62.3 (1,583)	79.4 (2,017)	57.4 (1,459)	62 (1,575)
R2	Boom swing radius, center	in (mm)	42.7 (1,085)	42.7 (1,085)	47 (1,195)	64.1 (1,627)	65.6 (1,666)	64.6 (1,641)	99 (2,506)	106.0 (2,692)	96.6 (2,453)	98.5 (2,503)	110 (2,814)	97.0 (2,465)	116.3 (2,953)
S	Track length total	in (mm)	48 (1,220)	48 (1,220)	57.6 (1,462)	63.3 (1,607)	67.2 (1,708)	79 (2,006)	99 (2,507)	99.4 (2,524)	99.1 (2,516)	111.3 (2,826)	141.9 (3,604)	113.7 (2,887)	125.7 (3,193)
W1	Max. boom swing angle right	°	56	56	49	57	48	50	45	61	63	63	57	63	63
W3	Max. boom swing angle left	°	55	55	73	65	77	75	70	65	67	67	70	67	67
X	Track/tire width	in (mm)	7.1 (180)	7.1 (180)	9.1 (230)	9.1 (230)	n/a	11.8 (300)	11.8 (300)	15.7 (400)	15.7 (400)	98.3 (2,498)	19.7 (500)	11.8 (300)	20.2 (514)
Z1	Transport length (standard dipper stick)	in (mm)	111.42 (2,828)	111.42 (2,828)	143.5 (3,644)	141.1 (3,584)	159.4 (4,049)	168 (4,266)	207.4 (5,268)	216.5 (5,498)	241.6 (6,137)	98.4 (2,499)	-	240.7 (6,114)	-
Z2	Transport length (long dipper stick)	in (mm)	-	-	142 (3,606)	139.8 (3,551)	n/a	168.2 (4,272)	217/204 (5,503/5,189**)	215.6 (5,477)	241.3 (6,128)	281.1 (7,139)	306.6 (7,788)	246.1 (6,250)	288.0 (7,315)

* with hybrid chain ** unit equipped with the VDS option

Tracked excavators

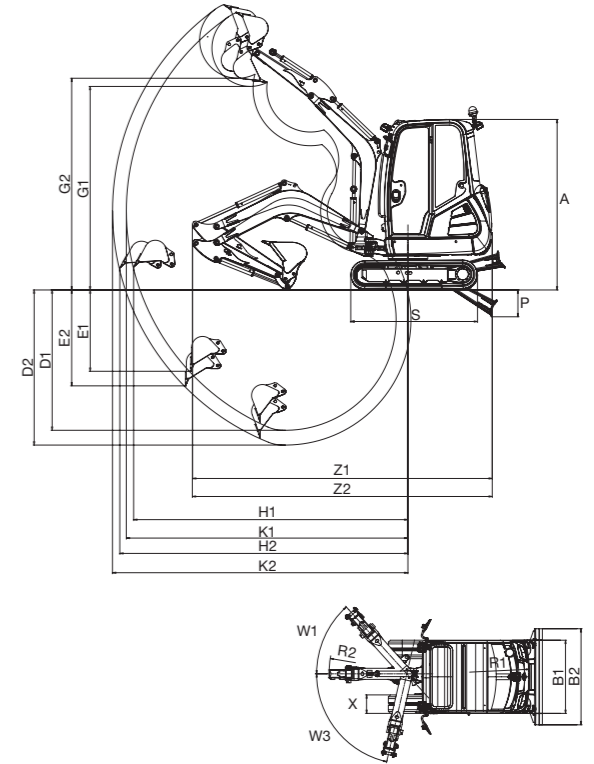

Wheeled excavators

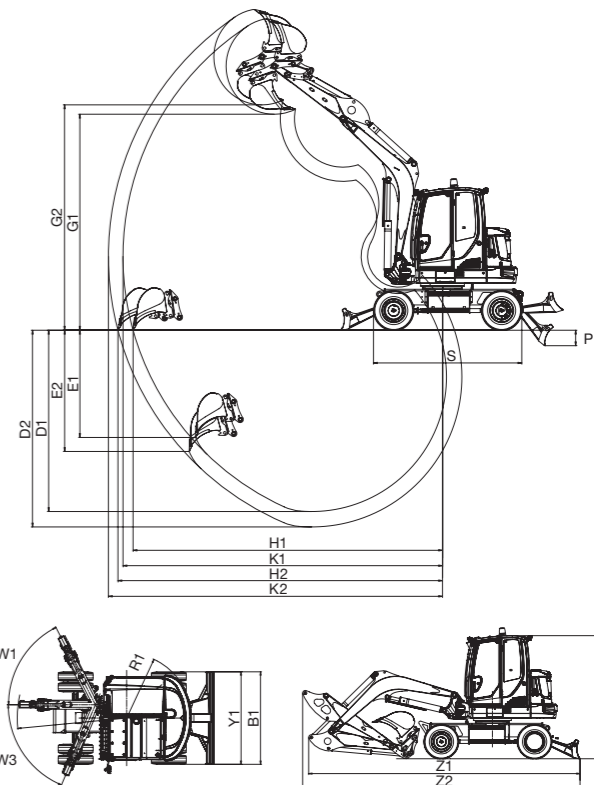

Technical data

MINI, COMPACT AND WHEELED EXCAVATORS

		803	803 dualpower	ET16	EZ17	ET20	EZ26	EZ36	EZ53	ET65	ET90	ET145	EW65	EW100	
GENERAL		UNIT													
Shipping weight*	lbs (kg)	2,055–2,187 (932–992)	2,194–2,238 (955–1,015)	3,091–3,532 (1,402–1,602)	3,519–4,017 (1,596–1,822)	4,105–4,810 (1,862–2,182)	5,723–6,158 (2,596–2,793)	7,372–9,392 (3,344–4,260)	10,953–13,592 (4,968–6,165)	12,800–14,731 (5,806–6,682)	18,404–21,219 (8,348–9,625)	32,886–34,615 (14,917–15,701)	14,268–17,020 (6,472–7,720)	20,373–23,063 (9,241–10,461)	
Operating weight	lbs (kg)	2,268.53– 2,400.81 (1,029–1,089)	2,319.24– 2,451.52 (1,052–1,112)	3,371–3,792 (1,529–1,720)	3,801–4,299 (1,724–1,950)	4,420–5,125 (2,005–2,324)	5,668–7,191 (2,571–3,262)	8,201–10,221 (3,720–4,636)	11,539–14,178 (5,234–6,431)	13,400–15,331 (6,078–6,954)	19,202–22,020 (8,710–9,988)	34,284–36,012 (15,551–16,335)	14,892–17,643 (6,755–8,003)	21,352–24,330 (9,685–11,036)	
Max. digging force**	lbf (kN)	1,012 (4.5)	1,012 (4.5)	1,596 (7.1)	2,046 (9.1)	2,810 (12.5)	3,439.58 (15.3)	4,743.47 (21.1)	6,295 (28)	6,924 (30.8)	10,341 (46)	15,512 (69)	6,924 (30.8)	10,566 (47)	
Max. breakout force	lbf (kN)	2,001 (8.9)	2,001 (8.9)	3,192 (14.2)	4,204 (18.7)	4,226 (18.8)	5,058.2 (22.5)	7,868.32 (35)	8,565 (38.1)	11,398 (50.7)	16,591 (73.8)	20,458 (91)	11,398 (50.7)	10,308 (50.3)	
ENGINE		UNIT													
Manufacturer	–	Yanmar		Yanmar	Yanmar	Yanmar	Yanmar	Yanmar	Perkins	Perkins	Deutz	Perkins	Perkins	Perkins	
Model	–	3TNV74F		3TNV80F	3TNV80F	3TNV80F	3TNV80F	3TNV88F	404F-22T	404F-E22TA	TCD 2.9	854E-E34TAWF	404F-E22TA	854F-E34TTF	
Type	–	Water-cooled 3-cylinder diesel engine	Drive either with installed diesel engine (compare 803) or electric motor in HPU8 drive unit	Water-cooled 3-cylinder diesel engine	Water-cooled 3-cylinder diesel engine	Water-cooled 3-cylinder diesel engine	Liquid-cooled, 3-cylinder diesel engine	3 cylinder Yanmar diesel engine	Water-cooled 4-cylinder turbo diesel engine	Water-cooled 4-cylinder turbo diesel engine in series	Water-cooled 4-cylinder turbo diesel engine in series	Water-cooled 4-cylinder turbo diesel engine	Water-cooled 4-cylinder turbo diesel engine in series	Water-cooled 4-cylinder turbo diesel engine	
Displacement	in ³ (cm ³)	60.6 (993)		77 (1,266)	77.2 (1,266)	77.3 (1,266)	77.3 (1,266)	100.2 (1,642)	135.2 (2,216)	135.2 (2,216)	178.1 (2,920)	206.7 (3,387)	135.2 (2,216)	206.7 (3,387)	
Engine output	hp (kW)	15.4 (11.6)		17.7 (13.2)	17.2 (12.8)	17.9 (13.4)	20.4 (15.2)	24 (17.8)	58.9 (45.5)	67.1 (50)	74.3 (55.4)	73.8 (55)	67.1 (50)	73.8 (55)	
Fuel tank capacity	gal (l)	1.8 (7)		6.3 (24)	5.8 (22)	6.3 (24)	9.5 (36)	11.62 (44)	21.9 (83)	22.5 (85)	22.5 (85)	54.2 (205)	22.5 (85)	44.9 (170)	
HYDRAULICS		UNIT													
Hydraulic system/pumps	–	2 gear pumps		gear pump	Load Sensing Hydraulic System/ 1 displacement pump	Double variable pump with 2 gear pumps	Double variable- and two-gear pump	Dual variable displacement pump, double hydraulic gear pump	Double variable and two-gear pump	Variable displacement pump	Variable displacement pump and gear	Double variable pumps, 2 gear wheels	Variable displacement pump and double hydraulic gear pump	LUDV with variable displacement pump, seperate travel pump	
Max. flow rate	gal (l)/min	2.8+2.8 (10.7 + 10.7)	2.8+2.8 (10.7 + 10.7)	8.8 (33.3)	10.5 (39.6)	19.3 (73)	23.8 (90.2)	11.62 (2x41.3+23.1+10.9)	28.1 (106.4)	45.6 (172.8)	46.4 (175.8)	77.1 (291.9)	49.5 (187.2)	47.6 (180)	
Operating pressure for work and drive hydraulics	psi (bar)	2,466 (170)	2,466 (170)	2,901 (200)	3,481 (240)	2,901 (200)	3,263 (225)	3,481 (240)	3,336 (230)	3,481 (240)	4,351 (300)	4,931 (340)	6,092 (420)	6,382 (440)	
Operating pressure for slewing gear	psi (bar)	1,015 (70)	1,015 (70)	1,886 (130)	2,176 (240)	2,176 (240)	2,988 (206)	2,756 (190)	2,756 (190)	3,118 (215)	3,481 (240)	4,641 (320)	3,481 (240)	4,206 (290)	
Auxiliary hydraulics, max. delivery rate	gal (l)/min	3.7 (14)	3.7 (14)	5.3 (20)	5.6 (21)	5 (19)	138 (52.2)	174.6 (66.1)	19.3 (73)	24.3 (92)	24.3 (92)	29.1 (110)	24 (92)	31.7 (120)	
TRANSPORT GEAR		UNIT													
Ground clearance	in (mm)	5.2 (132)	5.1 (132)	7.1 (180)	6.3 (160)	6.7 (170)	10.91 (277)	9.9 (251)	12.7 (322)	11.1 (284)	14.6 (370)	18.9 (480)	9.3 (237)	14.2 (340)	
Travel speed	mph (km/h)	1.1 (1.8)	1.1 (1.8)	2.5 (4.1)	3.0 (4.8)	2.5 (4.1)	2.4 (3.8)	1.7/2.9 (2.7/4.7)	2.9 (4.7)	3.2 (5.2)	3.1 (5)	3.1 (5)	18.6 (30)	18.6 (30)	
NOISE EMISSIONS		UNIT													
Sound power level (L _{WA})	dBA according to 2000/14/EC	93	93	93	93	93	93	–	94	98	99	99	97	101	
Sound pressure level (L _{PA})	dBA according to ISO 6394	77	77	79	79	77	79	–	78	77	79	75	–	–	

* Basic machine + 10% fuel tank capacity ** short dipper stick

HPU8	MODEL	LENGTH	WIDTH	HEIGHT	WEIGHT	ENGINE	PERFORMANCE	VOLTAGE	CURRENT CONSUMPTION	HYDRAULIC PUMP DELIVERY RATE	OPERATING PRESSURE	HYDRAULIC OIL TANK CAPACITY	HYDRAULIC HOSE LENGTH
	HPU8	36.6 in	28.3 in	39.4 in	423 lbs	3-phase electric motor	10.0 hp/7.5 kW	480 V	16 A	5.2 gal/min	2,756 psi	2.5 gal	39.4 ft

All information relates to the base machine. The right to make technical changes reserved.

Your work day is full of challenges. We have the right solutions to help you stay ahead of the competition. We offer you everything you need for this purpose: **Wacker Neuson—all it takes!**

Products



Concrete Technology

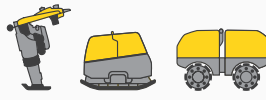

Compaction



Skid Steer Loaders



Excavators



Wheel



Telehandlers



Dumpers

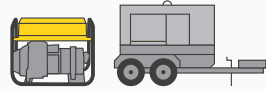

Generators

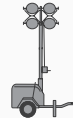

Lighting



Pumps

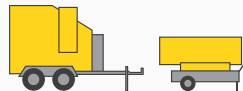

Heaters



Used Equipment

Services



University

Practice-focused education within an ideal learning environment.



EquipCare

Fleet management solutions via app or desktop computer.



Genuine Parts

Use our original spare parts for service and to maintain optimum performance.



Finance

Uncomplicated, transparent and individual financing options for you.



ePartner

Our dealers have fast and easy online access to machines and spare parts.



Warranty

Our excavators feature a five-year factory warranty. Available in USA and Canada.



Certified Pre-Owned

Used machines from Wacker Neuson—full power, lower prices.

www.wackerneuson.com

Wacker Neuson is proud to be a global brand. Not all configurations shown in the pictures may be available in the North American market.

0986240 08/2019 EN