

WL60T

Telescopic Wheel Loaders



**WACKER
NEUSON**
all it takes!



Articulated wheel loader with telescopic boom

The WL60T telescopic wheel loader is equipped with a 102 HP Tier 4 Final turbo-charged Perkins diesel engine delivering best-in-class power and performance, and with the telescopic boom additional height, added versatility and greater production is achieved. The WL60T features a telescopic arm that delivers

16' 8" hinge pin height to easily manage high sided trucks and material containers. The articulated wheel loader provides stable and maneuverable operation especially in tight spaces.

- Tier 4 Final Perkins engine offers a Selective Catalytic Reduction (SCR)/Diesel Oxidation Catalyst (DOC) as an aftertreatment which requires no diesel particulate filter, no regeneration and no maintenance
- The spacious climate-controlled cab features multi-adjustable air-ride seat, impressive 360° visibility along with ergonomically designed joysticks and controls to maximize operator comfort
- Excellent service access with side tilting cab and rear engine hood minimizes time to perform daily maintenance and periodical service resulting in more time on the job
- Class leading travel speeds up to 24.9 mph (optional) shortens travel time across job sites, improving cycle times
- Universal hydraulic attachment plate with standard 26 gpm auxiliary hydraulic flow accommodates most existing skid steer attachments

WL60T Technical specifications

Engine / Motor

Engine / Motor manufacturer	Perkins
Engine / Motor type	854F-E34TA
Cylinder	4
Engine performance	102 hp
at rpm	2,500 rpm
Displacement	207.4 in ³
Coolant type	Water / Charge air

Electrical system

Operating voltage	12 V
Battery	95 Ah
Alternator	120 A

Operating data

Operating weight	13,448 lb
Speed - standard	12.4 mph
Speed - optional	24.9 mph
Bucket capacity	1.5 yd ³
Payload	7,433.9 lb
Tipping load with bucket - machine straight	7,433.9 lb
Tipping load with pallet fork - machine straight	6,990.8 lb
Standard tires	600/40-22.5 AS ET-50
Service brake	disc brakes
Traction drive	Hydrostatic with universal joint shaft
Axles	PA 1422

Steering and operating hydraulics

Driving hydraulics - operating pressure	6,454.3 psi
Operating hydraulics - operating pressure	3,408.4 psi
Operating hydraulics - discharge capacity	26 US gpm
Steering angle	42 °

Filling capacities

Fuel tank capacity	27.3 US gal
Hydraulic oil tank	100.3 US qt

Sound level

Average sound power level L _{WA}	101 dB(A)
Guaranteed sound power level L _{WA}	103 dB(A)
Specified sound pressure level L _{pA}	78 dB(A)

WL60T Dimensions

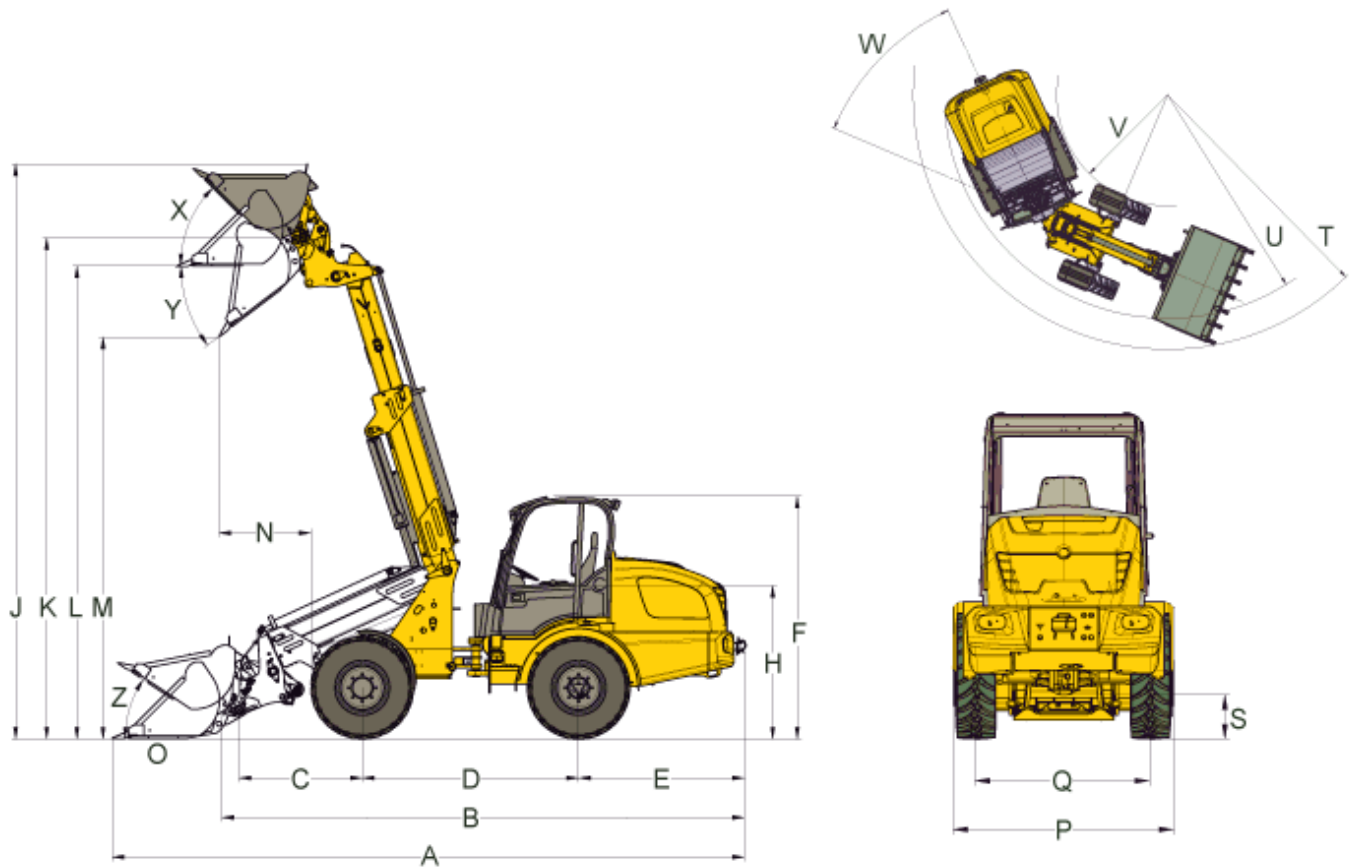

A	Overall length	251.8 in
B	Overall length without bucket	204.7 in
C	Bucket pivot point to axle center	49 in
D	Wheelbase	86.2 in
E	Rear overhang	66 in
F	Cabin height	105.5 in
H	Seat height	63.3 in
J	Total operating height	229.3 in
K	Stroke height max. - bucket pivot point	199.8 in
L	Overhead loading height	188.6 in
M	Dump height max.	160.3 in
N	Dump reach at M	36.7 in
P	Overall width	82 in
Q	Track width	56 in
S	Ground clearance	14.2 in
T	Radius maximum	177.6 in
U	Radius at outer edge	154.7 in
V	Inside turning radius	76.8 in
W	Articulation angle	42 °
X	Bucket rollback at max. stroke height	45 °

Y	Dump angle	33 °
Z	Bucket rollback at ground level	41 °

Please note: that product availability can vary from country to country. It is possible that information / products may not be available in your country. More detailed information on engine power can be found in the operator's manual; the stated power may vary due to specific operating conditions. Subject to alterations and errors excepted. Applicable also to illustrations.

Copyright © 2020 Wacker Neuson SE.