

# WL60

## Articulated Wheel Loaders



**WACKER  
NEUSON**  
*all it takes!*



### Articulated Wheel Loader offers power and speed

The WL60 is the most powerful compact wheel loader in its size class. Powered by a 102HP Tier 4 Final engine, the WL60 delivers unmatched power and performance. The WL60 offers the speed and payload to handle a variety of job site needs. With a universal hydraulic attachment plate and standard hydraulic flow (26 gpm) or high flow (40 gpm), changing and operating existing or new attachments is quick and easy. A class-leading hinge pin height of 12 feet allows for loading and unloading high sided dump trucks and hoppers. The articulated joint allows for the unit to be highly maneuverable especially in tight working conditions.

- Tier 4 Final Perkins engine offers a Selective Catalytic Reduction (SCR)/Diesel Oxidation Catalyst (DOC) as an aftertreatment which requires no diesel particulate filter, no regeneration and no maintenance
- The spacious climate-controlled cab features multi-adjustable air-ride seat, impressive 360° visibility along with ergonomically designed joysticks and controls to maximize operator comfort
- Excellent service access with side tilting cab and rear engine hood minimizes time to perform daily maintenance and periodical service resulting in more time on the job
- Class leading travel speeds up to 24.9 mph (optional) shortens travel time across job sites, improving cycle times
- Universal hydraulic attachment plate with standard 26 gpm auxiliary hydraulic flow or high flow of 40 gpm accommodates most existing skid steer attachments



## WL60 Technical specifications

### Engine / Motor

Engine / Motor manufacturer	Perkins, 854F-E34TA
Engine / Motor type	Turbo-Charged, water-cooled, 4-cylinder diesel engine
Cylinder	4
Engine performance	102 hp
at rpm	2,500 rpm
Coolant type	Water

### Electrical system

Operating voltage	12 V
Battery	95 Ah
Alternator	120 A

### Weights

Operating weight Cab	13,007 lb
Breakout force	7,898 lbf
Tipping load with bucket - machine straight	8,100 lb
Tipping load with bucket - machine at angle	6,682 lb

### Vehicle data

Bucket capacity	1.5 yd <sup>3</sup>
Speed Level 1	12 mph
Speed Level 2 - Optional	24.5 mph
Standard tires	405/70-18EM ETO

### Hydraulic system

Driving hydraulics - operating pressure	6,454.28 psi
Operating hydraulics - operating pressure	3,045.84 psi
Operating hydraulics - discharge capacity	26 US gpm
Operating hydraulics - discharge capacity	39 US gpm

### Filling capacities

Tank capacity	27.3 US gal
Hydraulic oil tank	100.3 US qt

### Sound level

Average sound power level LwA	101 dB(A)
Guaranteed sound power level LwA	103 dB(A)
Specified sound pressure level LpA	78 dB(A)

## WL60 Dimensions

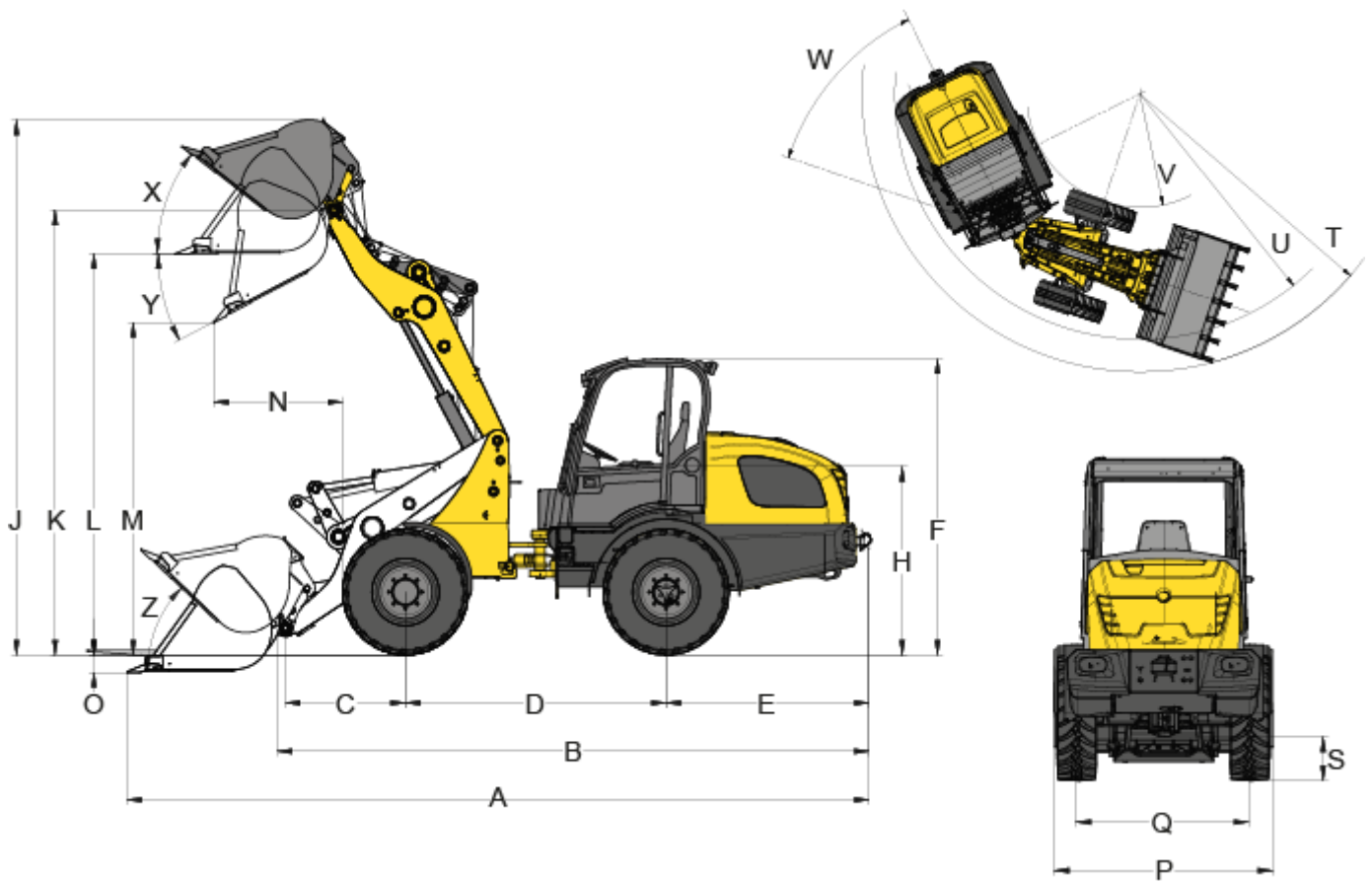

	Standard tires	405/70-18EM ETO
A	Overall length with standard bucket	232.2 in
B	Overall length without bucket	188.2 in
C	Bucket pivot point to axle center	39 in
D	Wheelbase	84.7 in
E	Rear overhang	66 in
F	Height with cabin	106 in
H	Seat height	63.4 in
J	Total operating height	173.6 in
K	Stroke height max. - bucket pivot point	145.1 in
L	Overhead loading height	132.9 in
M	Dump height max.	111.9 in
N	Range at M	31.5 in
O	Scraping depth	2.9 in
P	Overall width	72 in
Q	Track width	56 in
S	Ground clearance	14.8 in
T	Radius maximum	160.3 in
U	Radius at outer edge	145.1 in
V	Inside turning radius	65.6 in
W	Articulation angle	45 °

X	Bucket rollback at max. stroke height	33 °
Y	Dump angle	33 °
Z	Bucket rollback at ground level	39 °

Please note: that product availability can vary from country to country. It is possible that information / products may not be available in your country. More detailed information on engine power can be found in the operator's manual; the stated power may vary due to specific operating conditions. Subject to alterations and errors excepted. Applicable also to illustrations.

Copyright © 2020 Wacker Neuson SE.