

RTC-SRT MODULE REAL-TIME SLUDGE RETENTION TIME CONTROL

Applications

- Municipal Wastewater
- Industrial Wastewater



Sludge Age. Under Control.

Hach®'s RTC-SRT System automatically adjusts the sludge age in the aeration basin. Particularly during the summer at higher water temperatures, a lower SRT can be applied, resulting in a higher organic content in the excess sludge which leads to a significantly higher methane yield in sludge digestion. In addition, savings in aeration energy due to a minimized endogenous respiration lead to a further improvement of the positive energy balance.

Increased methane yield from digester

At higher water temperatures a lower sludge age can be adjusted, resulting in a higher organic content in the activated sludge and thus to an increased methane yield from the digester.

Reduced energy consumption for aeration

Due to a minimized endogenous respiration aeration costs on COD removal can be reduced.

Improved compliance

The module makes sure that the sludge age is always sufficient to also deal with Nitrogen load peaks, thereby assuring compliance.

Predictive diagnostics

Prognosys is a predictive diagnostic system that allows you to be proactive in your maintenance, by alerting you to upcoming instrument issues. Know with confidence whether changes in your measurements are due to changes in your instrument or your sample.

When we say Service, we mean Service!

A complete Service package includes local field service experts to provide routine maintenance visits and warranty repair, plus a team of remote technical experts with the ability to monitor your system to ensure optimum performance. It's like having a Hach Technician right there with you at the facility.

Principle of Operation

The RTC-SRT controller calculates the required amount of excess sludge to be removed in order to adjust an aerobic sludge age ensuring stable nitrification and low energy cost for BOD removal. The calculation is based on the TSS concentration in the aeration basin and in the excess sludge or return activated sludge. Optionally, a TSS measurement in the effluent of the final sedimentation can be integrated in the calculation.

The required aerobic sludge age can either be entered manually or can automatically be calculated based on the actual mixed liquor temperature and aerated volume.

Adjustable limits for minimum and maximum TSS concentration in the aeration tank, minimal aerobic sludge age, minimum and maximum pumping rate of the excess sludge and safety factors ensure safe operation and process stability.

The RTC-SRT control software can be combined with other control software modules and has to be hosted by a specific hardware.

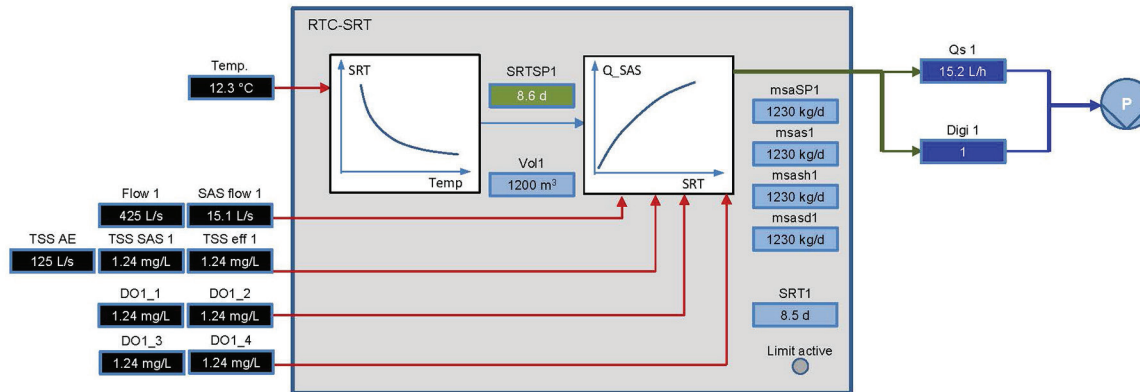

Order Information

RTC-SRT Module

LXZ518

RTC-SRT Module, software only. To be used with LXV515.
Control module for the optimization of the sludge age. Available as 1- or 2-channel version.

LXV515

IPC Hardware

Please note: Using RTC Module requires SC1000 controller and RTC card.

Be certain in your control with a first class Service Partner. Be confident with Hach Service.

Hach's Commissioning Service for RTC provides the insurance that your complete Real Time Control solution is installed and configured properly as well as optimized efficiently. During the commissioning period (Start Up phase, Commissioning phase, Hand over phase), Hach will thoroughly monitor your system and review and analyse your data remotely in order to provide guidance to optimize your RTC at its highest performance and efficiency levels for your application.

HACH COMPANY World Headquarters: Loveland, Colorado USA

United States: 800-227-4224 tel 970-669-2932 fax orders@hach.com

Outside United States: 970-669-3050 tel 970-461-3939 fax int@hach.com

hach.com

Printed in U.S.A.

©Hach Company, 2017. All rights reserved.

In the interest of improving and updating its equipment, Hach Company reserves the right to alter specifications to equipment at any time.



Be Right™