

# DV90

## Dual View Dumpers



**WACKER  
NEUSON**  
*all it takes!*



### Redefined safety: Everything in sight with the dumper DV90

The DV90 dual view sets new standards in terms of operator and job site flexibility, economic efficiency and enhanced safety. The dual view concept allows a comfortable and quick change of the seat position through a 180° turn of the entire operating and seat console. This system gives the operator the best view of the job site, travel direction and loading and unloading. The rotation can be performed conveniently from the driver's seat by simply unlocking the seat console and turning it around. All main functions, adjustable seat, steering wheel, joystick handle, throttle, brake pedal and multi-function display rotate with the seat.

- Ideal driving and working position
- Simple and intuitive operation with the ergonomic rotary console
- Hydrostatic drive
- Large comfortable cab with high efficiency HVAC system
- Ideal for construction, landscape, golf course, cemetery, municipal and rental applications

## DV90 Technical specifications

### Operating data

Payload	19,841 lb
Shipping weight	11,144 lb
Shipping weight	11,144 - 11,607 lb
Operating weight	11,179.53 - 11,896.02 lb
Skip capacity - water	541.6 US gal
Skip capacity - heaped	5.7 yd <sup>3</sup>
Skip capacity - struck	4.3 yd <sup>3</sup>

### Engine / Motor

Engine / Motor manufacturer	DEUTZ
Engine / Motor type	TD2.9 L4
Engine / Motor	water-cooled 4-cylinder turbo-diesel
Engine performance	74.2 hp
Displacement	177 in <sup>3</sup>
Engine RPM	2200 rpm
Emissions	level 3b / Tier IV final
Traction drive	4WD / hydrostatic
Travel speed max.	18.64 mph
Articulation angle	29 °
Pendulum angle	11 °
Turning radius	255.75 in
Gradeability	50 %
Tires	500/60-22.5
L x W x H	182.0 / 95.3 / 133 in
Steering pump	axial piston pump
Flow rate	32.5 US gpm
Operating pressure	6,961.9 psi
Duty pump	gear pump
Flow rate	18.5 US gpm
Operating pressure	3,481 psi
Tank capacity	84.5 US qt
Hydraulic oil tank	16.9 US gal
Sound level (LwA)	101 dB(A)

## DV90 Dimensions

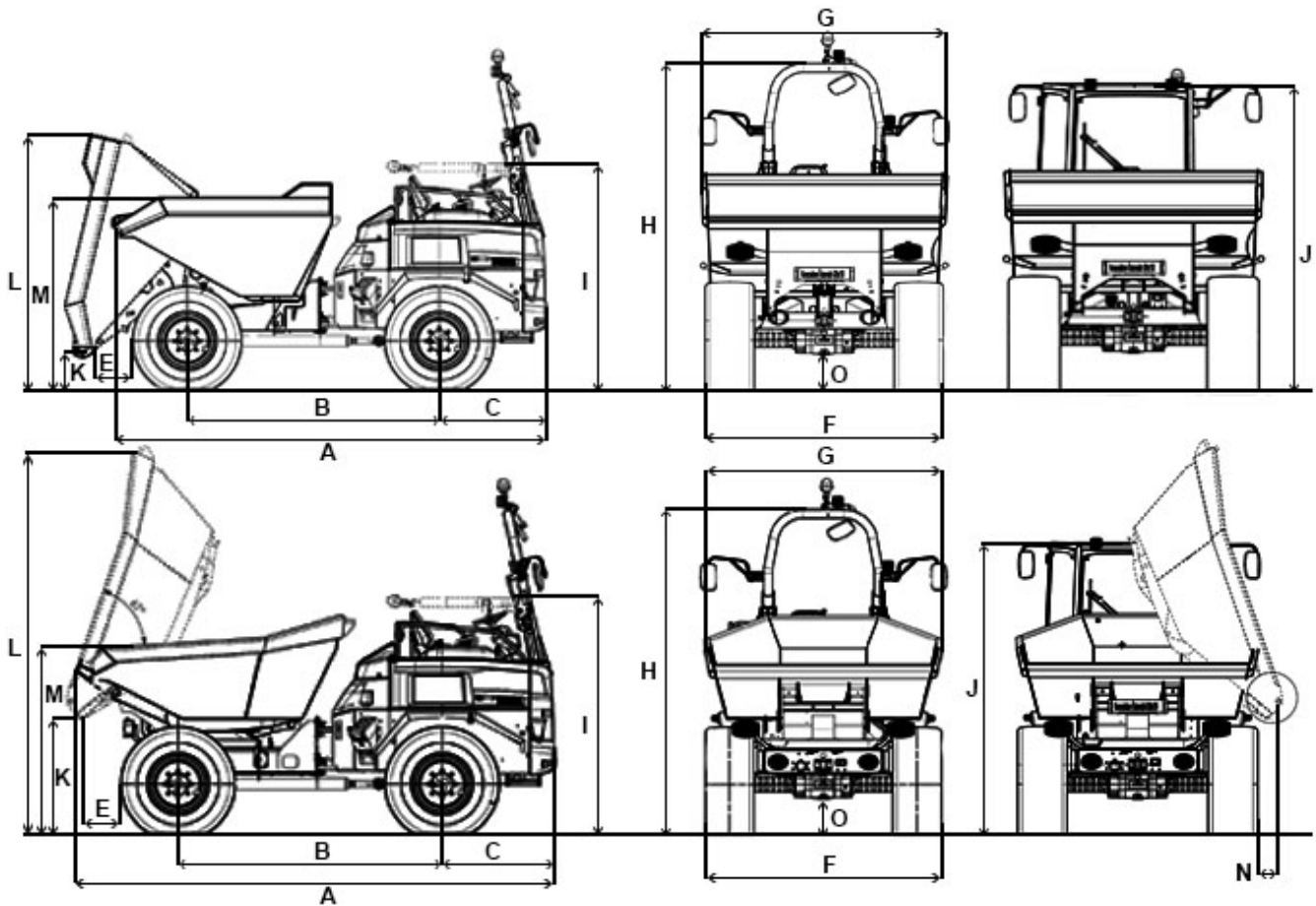

		Front tip skip	Swivel tip skip
A	Overall length ROPS	182.11 in	192.71 in
A	Overall length Cabin	182.11 in	192.71 in
B	Wheelbase	106.4 in	106.4 in
C	Rear overhang	45.6 in	45.6 in
E	Dumping distance	20.49 in	18 in
F	Width	95.3 in	95.3 in
G	Skip width	98.38 in	96.6 in
H	Height ROPS	133.25 in	133.25 in
I	Height ROPS tilted	94.8 in	94.76 in
J	Height Cabin	116 in	116.03 in
K	Dump height max.	14.07 in	48.07 in
L	Skip height tilted	107.29 in	156.81 in
M	Skip height not tilted	77.66 in	87.9 in
N	Dumping distance to the side		5.99 in
O	Ground clearance	14.07 in	14.1 in
-	Dump angle	48 °	40.1 °

Please note: that product availability can vary from country to country. It is possible that information / products may not be available in your country. More detailed information on engine power can be found in the operator's manual; the stated power may vary due to specific operating conditions. Subject to alterations and errors excepted. Applicable also to illustrations.  
Copyright © 2020 Wacker Neuson SE.