

# DT10

## Track Dumpers



**WACKER  
NEUSON**  
*all it takes!*



### Confined area material handling

Wacker Neuson's DT10 track dumper is an excellent material handling solution for smaller jobs that need the advantages of a tracked machine. The compact machine is designed for smooth travel while maneuvering across rough terrain and over curbs. The DT10 is designed for high performance and lower cost of ownership.

- Hydrostatic drive provides for easy and comfortable operation without the need to change gears
- Quickly unload materials with precision with the choice of front tip skip with self-loading shovel, swivel tip skip or front tip skip platform
- Engine hood can be folded down for complete access to daily maintenance points for quick and easy servicing
- The rubber tracks and the optimum weight distribution reduce the ground pressure to prevent damage to sensitive surfaces and provides added stability
- Compact design for confined areas and can fit through narrow garden gates and doorways making them ideal for landscape, concrete, demolition, residential and rental applications

## DT10 Technical specifications

	Front tip skip w/ self loading shovel	Front tip skip platform	Swivel tip skip
<b>Operating data</b>			
Shipping weight lb	1,532	1,301	1,708.5
Payload max. lb	2,645	2,645	2,645
Skip capacity leveled US gal	103.83	79.2	113.9
Skip capacity heaped US gal	117.83	55.5	121.5
L x W x H in	72 x 33 x 50	74 x 32 x 50	77 x 28 x 50
<b>Engine / Motor</b>			
Engine / Motor type	Kubota	Kubota	Kubota
Engine performance Diesel hp	13	13	13
at rpm rpm	3,600	3,600	3,600
Travel speed mph	2.5	2.5	2.5
Gradeability %	36	36	36
Fuel tank capacity US gal	2.5	2.5	2.5

## DT10 Dimensions

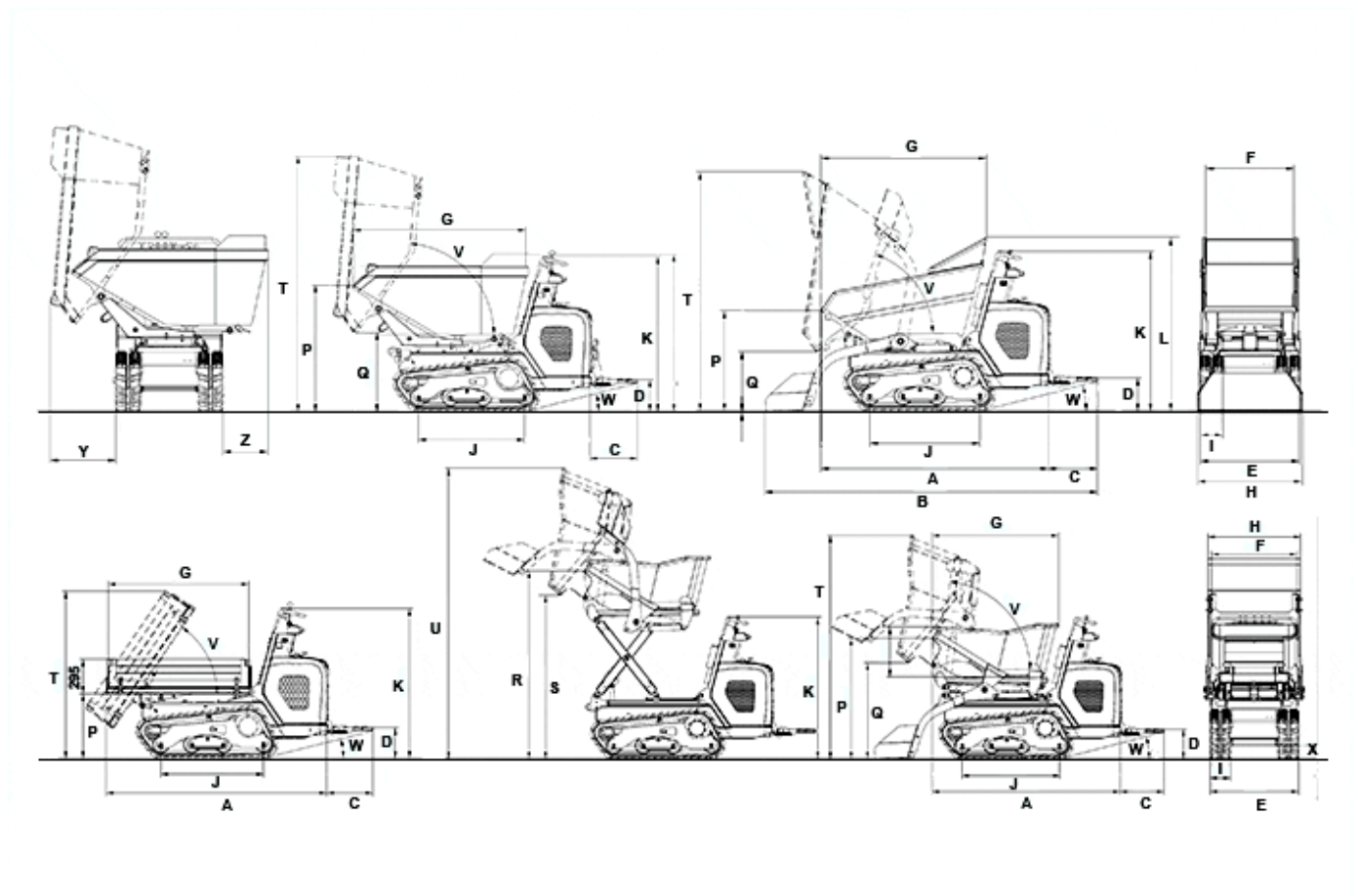

Front tip skip

	Swivel tip skip	Front tip skip platform	Front tip skip
A	Length (w/o operator stand board) 70.92 in		74.15 in
B	Length with self-loading system (w/o operator stand board) 89.32 in		
C	Length operator stand board 15.48 in		15.48 in
D	Height above stand board 10.44 in		10.44 in
E	Width undercarriage 31.13 in		31.13 in
F	Skip width 27.58 in		31.76 in
G	Skip length 52.01 in		47.28 in
H	Width with self-loading system 32.7 in		
I	Chain width 7.09 in		7.09 in

J	Length track rise	34.47 in	34.47 in
K	Height over control console	50.43 in	50.43 in
L	Height	53.78 in	
P	Height of skip front edge	31.68 in	33.45 in
Q	Dump height max.	18.68 in	10.09 in
T	Height skip raised	75.06 in	56.34 in
V	Dump angle	70 °	56 °
W	Bucket rollback operator stand board	14 °	14 °
Y	Dumping distance	19.19 in	
X	Ground clearance	6.78 in	6.3 in
Z	Rear overhang	13.28 in	

Please note: that product availability can vary from country to country. It is possible that information / products may not be available in your country. More detailed information on engine power can be found in the operator's manual; the stated power may vary due to specific operating conditions. Subject to alterations and errors excepted. Applicable also to illustrations.  
 Copyright © 2020 Wacker Neuson SE.