

---

**FLOW-TEK**

# FLANGED SERIES

2 PIECE FLANGED FULL PORT 1/2" - 12" BALL VALVES  
F15 - ASME CLASS 150 | F30-ASME CLASS 300



 **Bray**<sup>®</sup>

[WWW.BRAY.COM](http://WWW.BRAY.COM)

THE HIGH PERFORMANCE COMPANY

# FLANGED SERIES BALL VALVES

Flow-Tek's F15/F30 Flanged Series ball valves feature a floating ball design for low torque and increased cycle life. As standard, large size valves feature trunnion-type ball support. These rugged ball valves are ideal for industrial applications.

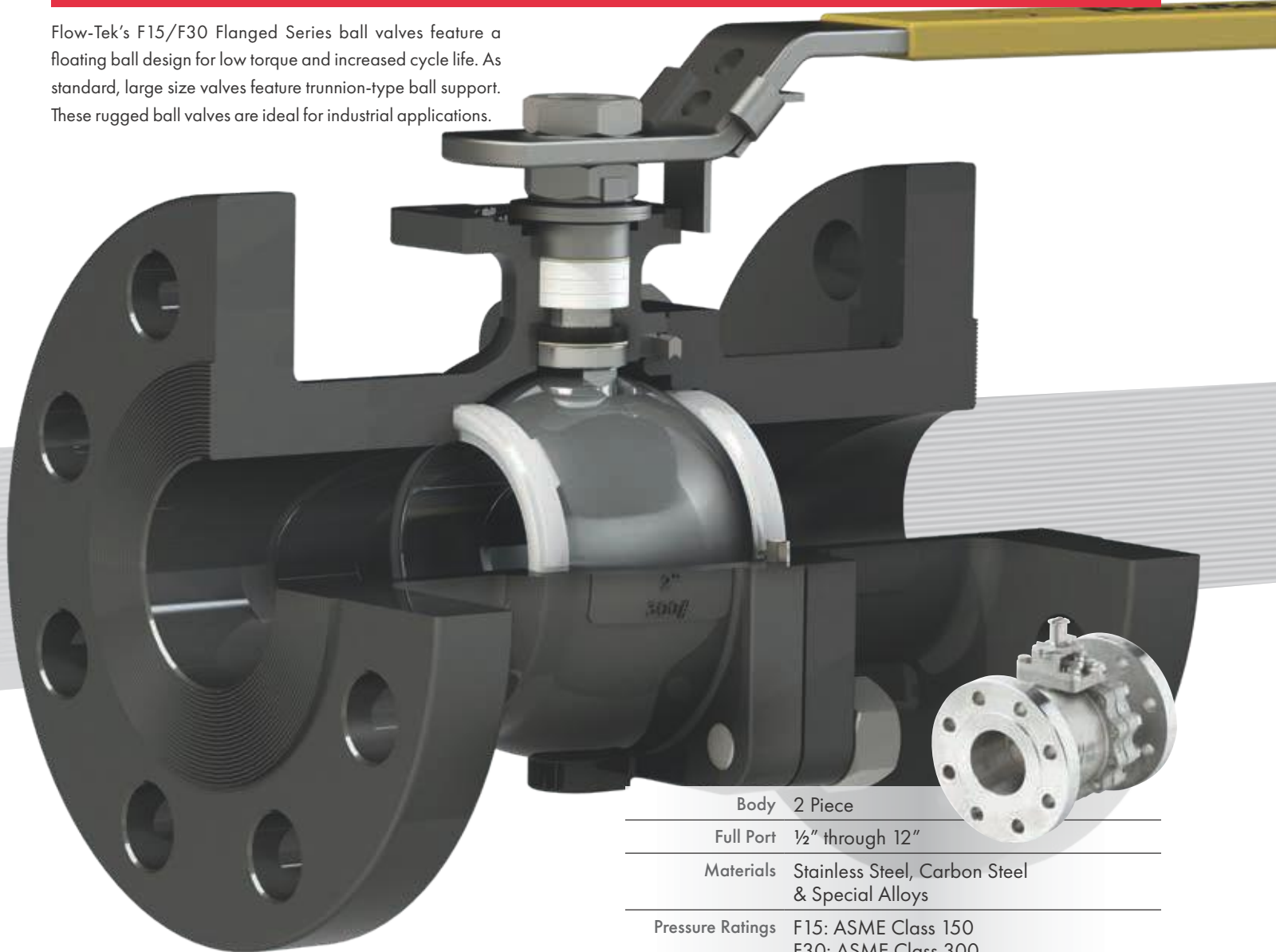

Body 2 Piece

Full Port ½" through 12"

Materials Stainless Steel, Carbon Steel  
& Special Alloys

Pressure Ratings F15: ASME Class 150  
F30: ASME Class 300

## SECURE MOUNT

Flanged Series valves offer ease of automation due to an integrally cast actuator mounting pad which complies with ISO 5211 through 2" valve sizes.

## STEM SEALS

Flanged Series ½" – 2" valves feature live-loaded, self-adjusting primary and secondary sealing. Utilizing Belleville washers, the stem seal automatically adjusts to compensate for changes in temperature and normal wear. 2½" – 12" valves utilize an independent packing gland which can be easily adjusted without removing mounting hardware or operator. The packing gland is contoured to more uniformly distribute the load across the packing. The primary stem seal is a combination of a thrust washer and a thrust washer protector. An adjustable stem packing creates a secondary seal between the stem and body. The stem packing is composed of RPTFE V-rings as standard – graphite stem packing is standard on all fire safe valves.

## BALL

Flow-Tek balls are precision machined and mirror finished for bubble-tight shut off and less operating torque. As an added safety feature, a hole in the stem slot of each ball equalizes pressure between the body cavity and the line media flow.

## BODY

½" – 4" valve bodies are investment cast and solution annealed/normalized for the highest quality and added strength. All body castings are marked with a foundry heat number for full traceability. Carbon steel bodies are phosphate coated for increased corrosion resistance.

## SEAT

Flow-Tek's seat design ensures bi-directional, bubble-tight sealing with low operating torque. All resilient seats feature relief slots or seat O.D. clearance to relieve pressure past the upstream seat, and positive preloading to ensure low pressure/vacuum sealing.

## STEM ASSEMBLIES

Flow-Tek manufactures heavy duty, high quality stems with double "D" connection to ball and operator mounting. Stem and ball design ensure positive contact. All Flow-Tek stems are internal entry and blowout proof for maximum safety.

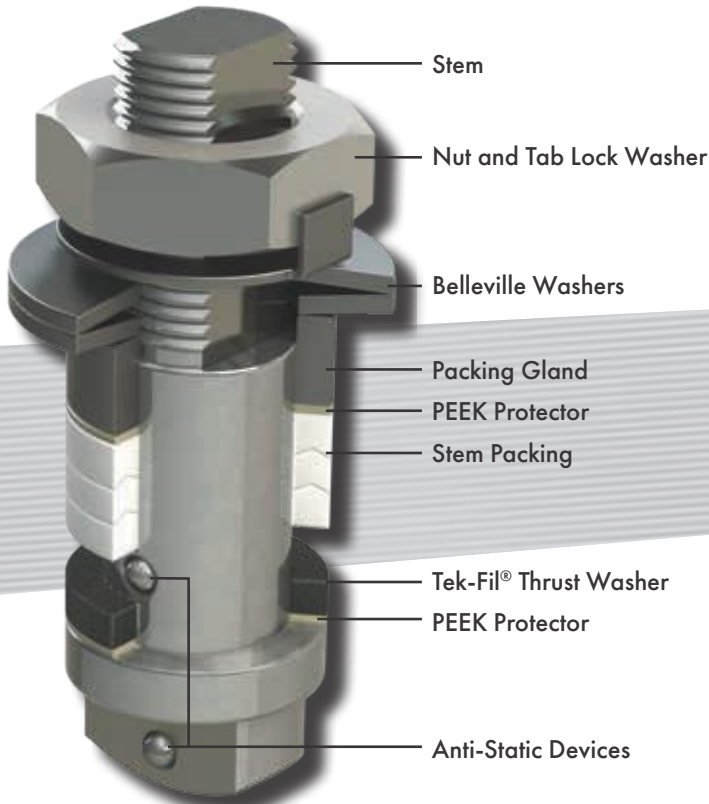

## SMART STEM Valve Sizes 1/2" through 2"

Flow-Tek's interchangeable family of valves feature strong, large diameter stems with live-loaded, self-adjusting sealing utilizing Belleville washers which automatically adjust to compensate for changes in temperature and wear. Manual adjustments which can cause damage to the seal and seat are not required. The assembly is secured by a saddle-type lock washer which prevents stem nuts from unthreading in high cycle automation applications.

## STEM PACKING

An adjustable V-ring design creates a multiple seal between the stem and body. Each stem assembly is composed of three or four (dependent on valve size) rings providing a very high cycle life by resisting creep and cold flow. The thrust washer and the thrust washer protector combine to provide a primary seal, reduce torque and prevent galling. This arrangement is a Flow-Tek exclusive.

## FIRE SAFE - Certified to API 607

Flanged Series valves with graphite stem seals have been thoroughly fire tested and meet these standards.

In the event of a fire, after heat destroys the primary resilient seat, the ball makes contact with the secondary metal seat, forming a secure seal. The body seal, composed of stainless steel and graphite wound into a spiral, prevents external leakage. The graphite stem rings prevent stem leakage.

## BALL SUPPORT Valve Sizes 6" through 12"

As standard, larger sized valves feature trunion-type ball support. This support helps to maintain continuous contact between the ball and seats, preventing seat damage and blow-by. The results are less seat wear, lower torque, and longer service life.

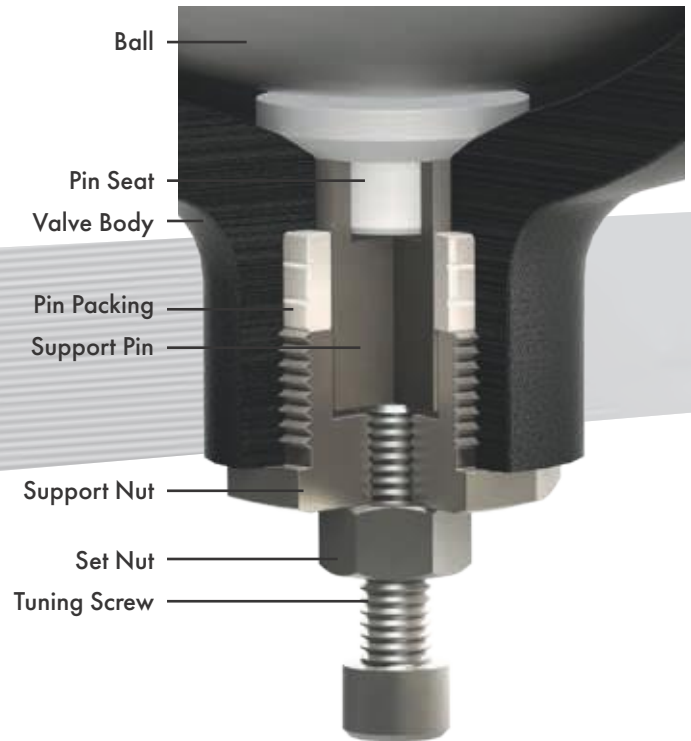

## LOCKING DEVICE

All manually operated valves feature a locking device to prevent accidental movement of ball position. Valves 1/2"–2" feature a safety trigger that locks the handle in the open or closed position. The handle lock can be bypassed, if needed, with a small bolt through the handle in the release position.



On all sizes a padlock can be added to secure the handle in position, preventing unwanted movement of the ball.





## PRESSURE / TEMPERATURE

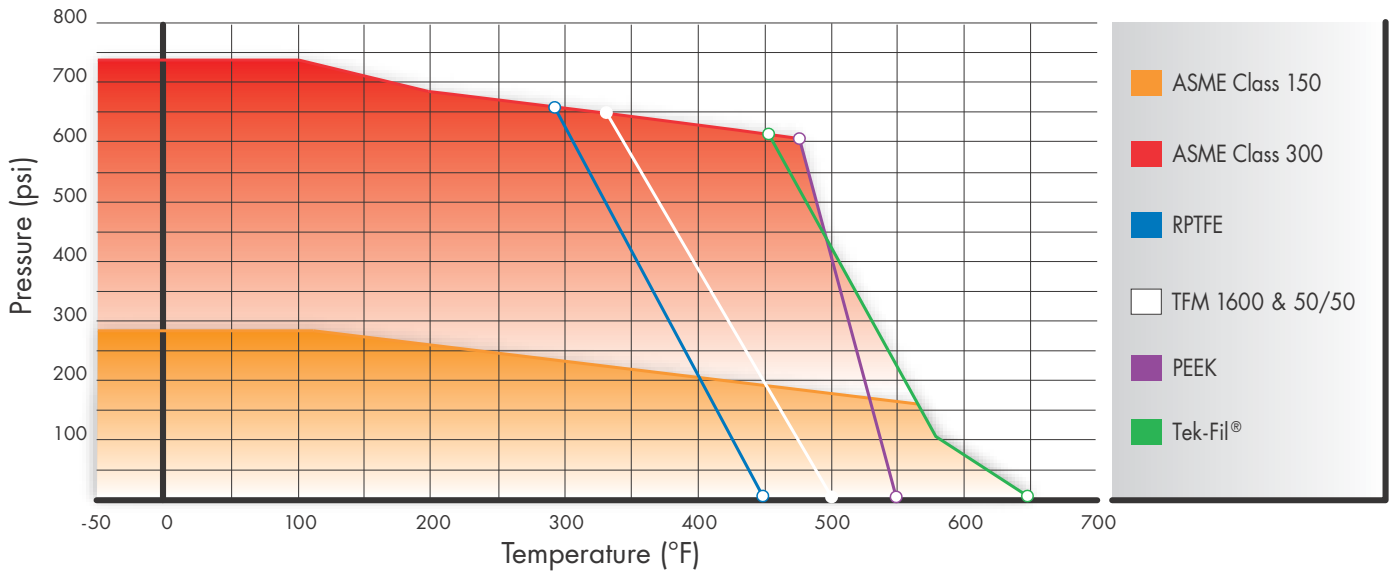

Carbon steel valves limited to -20°F

## STEAM SERVICE PRESSURE RATINGS: WSP

	TFM Seats		Tek-Fil Seats		PEEK Seats	
	PSI	°F	PSI	°F	PSI	°F
Class 150	150	365	190	383	170	374
Class 300	150	365	425	454	425	454

Vacuum service to 29.9 inches Hg. gauge.

## SPECIAL OPTIONS/SERVICES

Cavity Fillers	Media Containment Units
Spring Return Handles	NACE
Vented Balls	Polished Internals
Characterized Balls	Special Cleaning
Chlorine Service	Silicone Free
NSF/ANSI/CAN 61 & 372 Certification	

## SPECIFICATIONS

- Valve sizes 1/4" through 12"
  - Design meets MSS-SP-110
  - Threaded end connections meet ASME B1.20.1 NPT
  - Socket weld end connections meet ASME B16.11
  - Butt weld end (Schedule 40) connections meet MSS SP-72 / ASME B16.25
  - Flanged end connections meet ASME Class 150
- Valve body and end cap connections are high quality investment cast and solution annealed/normalized. Body and end cap wall thickness meets ASME B16.34.
- Valve stems are blow-out proof for maximum safety and meet ASME B16.34 specification.
- All valves are factory tested to MSS SP-72 and API 598.

## SEAT SELECTION

A wide range of seat materials are available to meet most applications. The standard seat is TFM 1600. Options include:

- RPTFE
- Stainless Steel/PTFE (50/50)
- UHMWPE
- Virgin PTFE
- PEEK
- Tek-Fil® (carbon/graphite filled TFM)
- Full metal seats
- Cavity Fillers



PEEK seats offer high pressure/temperature capability. Tek-Fil® seats offer reduced torque in high temperature, high cycle, and steam service applications. TFM 1600 seats offer the exceptional chemical resistance of PTFE plus lower porosity and permeability, improved temperature range and reduced valve torques.

# COMPONENTS & MATERIALS

ITEM/NAME	STAINLESS STEEL	CARBON STEEL	QTY.
1. Body	ASTM A351 Gr CF8M	ASTM A216 Gr WCB	1
2. End Cap	ASTM A351 Gr CF8M	ASTM A216 Gr WCB	1
3. Ball	ASTM A351 Gr CF8M		1
4. Seat	TFM 1600		2
5. Stem	ASTM A479 Type 316		1
6. Body Seal	Spiral Wound (316/Graphite)		1
7. Body Nut	ASTM A194 Gr 8		*
8. Body Stud	ASTM A193 B8	ASTM A193 B7	*
9. Anti-Static Device	SS304		2
10. Packing Protector	PEEK		1
11. Thrust Washer Protector	PEEK		1
12. Thrust Washer	Tek-Fil		1
13. Stem Bearing	15% RPTFE		1
14. Stem Packing	RPTFE or Graphite		**
15. Packing Gland	ASTM A167 Type 304		1
16. Packing Follower	ASTM A351 Gr CF8M	ASTM A216 Gr WCB	1
17. Gland Bolt	SS304		2
18. Belleville Washer	SS301		2
19. Tab Lock Washer	SS304		1
20. Travel Stop Housing	CF8M	WCB	1
21. Housing Bolt	SS304	Alloy Steel	4
22. Travel Stop	SS304	Zinc Plated Carbon Steel	1
23. Travel Stop Sleeve	ASTM A167 Type 304		1
24. Travel Stop Bolt	SS304		1
25. Handle	SS304 or Ductile Iron***		1
26. Lock Nut	ASTM A167 Type 304		2
27. Handle Bolt	Carbon Steel		1
28. Handle Sleeve	Vinyl through 2"		1
29. Locking Device	SS304		1
30. Snap Ring	Nickel Plated Carbon Steel		2

\* Quantity depends on valve size.

\*\* RPTFE packing is composed of 3 or 4 pieces depending on size.  
Graphite packing is composed of a single piece.

\*\*\* Ductile Iron used for valve sizes  $\geq 2\frac{1}{2}$ ".

Flow-Tek offers the seat, body seal, thrust washer and stem packing as recommended spare parts. These parts are available as a packaged repair kit.

## 2½" – 12" VALVES

Ball support is included on 6" - 12" F15 valves and 6" - 12" F30 valves.

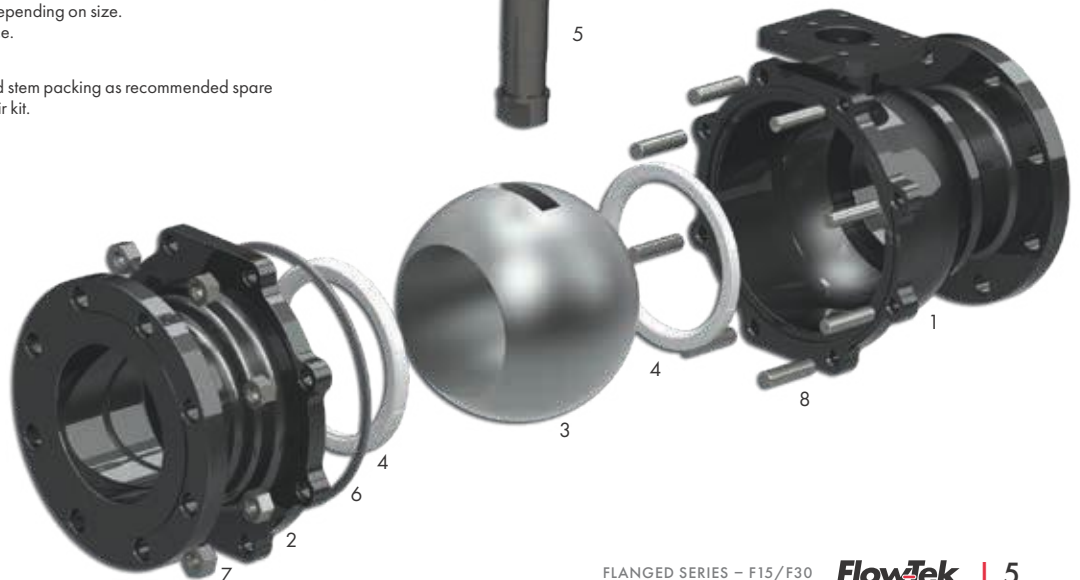

## ½" – 2" VALVES

Carbon steel bodies on valve sizes ½" – 4" are black phosphate coated.

All stainless steel bodies are solution annealed/normalized.



# F15/F30 DIMENSIONS 1/2" - 2" VALVES (15mm - 50mm)

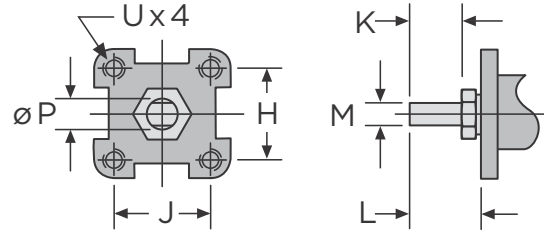
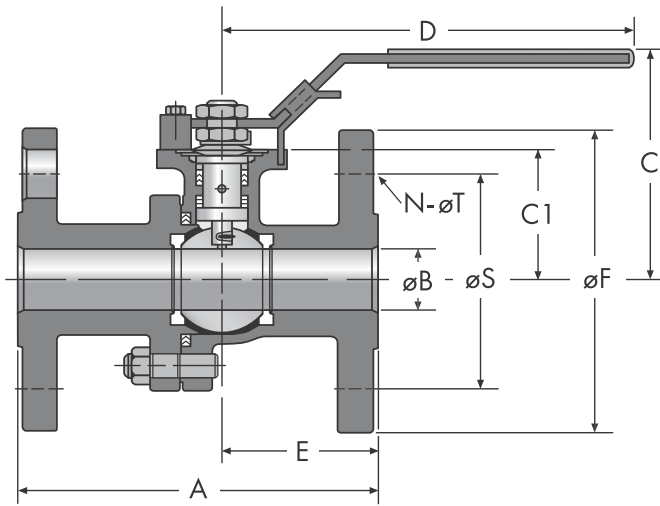

**DIMENSIONS – Secure Mount**

	Size	H	J	F0	BC DIA.	K	L	M	øP	U UNC
INCHES	1/2	1.17	1.17	F04	1.65	0.31	0.61	0.25	0.37	#10-24
	3/4	1.17	1.17	F04	1.65	0.31	0.61	0.25	0.37	#10-24
	1	1.39	1.39	F05	1.97	0.43	0.82	0.31	0.43	1/4-20
	1-1/2	1.95	1.95	F07	2.76	0.55	0.95	0.37	0.62	5/16-18
	2	1.95	1.95	F07	2.76	0.55	0.95	0.37	0.62	5/16-18
MILLIMETERS	15	29.7	29.7	F04	41.9	7.9	15.5	6.0	9.4	#10-24
	20	29.7	29.7	F04	41.9	7.9	15.5	6.0	9.4	#10-24
	25	35.0	35.0	F05	50.0	10.9	20.8	7.9	10.9	1/4-20
	40	49.5	49.5	F07	70.0	14.0	24.0	9.5	15.8	5/16-18
	50	49.5	49.5	F07	70.0	14.0	24.0	9.5	15.8	5/16-18

## Model F15 – Class 150

	Size	A	øB	C	C1	D	E	øF	øS	N / øT	C <sub>v</sub>	Torque*	Weight
INCHES	1/2	4.25	0.59	2.88	1.54	6.50	1.79	3.50	2.38	4 x 0.62	32	36	4
	3/4	4.62	0.79	2.97	1.67	6.50	2.01	3.88	2.75	4 x 0.62	60	65	5
	1	5.00	0.98	3.41	2.05	7.87	2.13	4.25	3.12	4 x 0.62	105	95	10
	1-1/2	6.50	1.49	4.20	2.60	9.84	2.76	5.00	3.88	4 x 0.62	275	230	14
	2	7.00	1.97	4.53	2.95	10.43	3.07	6.00	4.75	4 x 0.75	500	390	20.5
MILLIMETERS	15	108.0	15.0	73.25	39.0	165.0	45.5	88.9	60.5	4 x 15.8	28	4	2
	20	117.0	20.0	75.40	42.4	165.0	51.0	98.6	69.9	4 x 15.8	52	7	2
	25	127.0	24.9	86.69	52.0	199.9	54.0	108.0	79.0	4 x 15.8	91	11	4.5
	40	165.0	37.9	106.60	66.0	249.9	70.0	127.0	98.6	4 x 15.8	238	26	6
	50	177.8	50.0	115.01	74.9	264.9	78.0	152.0	120.7	4 x 19.0	433	44	9

## Model F30 – Class 300

	Size	A	øB	C	C1	D	E	øF	øS	N / øT	C <sub>v</sub>	Torque*	Weight
INCHES	1/2	5.50	0.59	2.92	1.57	6.50	2.44	3.75	2.62	4 x 0.62	32	40	5
	3/4	6.00	0.79	2.97	1.67	6.50	2.72	4.62	3.25	4 x 0.75	60	70	7
	1	6.50	0.98	3.41	2.05	7.87	2.91	4.88	3.50	4 x 0.75	105	108	10
	1-1/2	7.50	1.49	4.04	2.60	9.84	3.27	6.12	4.50	4 x 0.88	275	270	19
	2	8.50	1.97	4.53	2.95	10.43	3.94	6.50	5.00	8 x 0.75	500	445	25
MILLIMETERS	15	139.7	15.0	74.23	39.9	165.0	62.0	95.0	66.6	4 x 15.8	28	5	2
	20	152.0	20.0	75.40	42.0	165.0	69.0	117.0	82.6	4 x 19.0	52	8	3
	25	165.0	24.9	86.61	52.0	199.9	73.9	124.0	88.9	4 x 19.0	91	12	5
	40	190.5	37.9	102.50	66.0	249.9	83.0	155.5	114.0	4 x 22.0	238	31	9
	50	215.9	50.0	115.06	74.9	264.9	100.0	165.0	127.0	8 x 19.0	433	50	11

Face to Face dimensions meet ASME B 16.10 long pattern and short pattern (sizes 1/2" thru 2").

\*Torque at maximum rated pressure, clean water, TFM 1600 seating material. Other seat materials exhibit different torques.

Please refer to TB 1005 for specific torques.

## F15/F30 DIMENSIONS 2½" – 12" VALVES (65mm - 300mm)

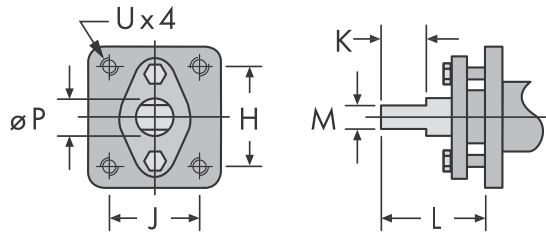

**DIMENSIONS – Secure Mount**

	Size	H	J	F0	BC DIA.	K	L	M	øP	U UNC
INCHES	2-1/2 - 4	3.54	1.87	—	—	1.75	3.10	0.67	1.10	1/2-13
	6	3.37	3.37	F12	4.77	1.61	3.58	1.02	1.71	1/2-13
	8 <sup>1</sup>	3.37	3.37	F12	4.77	2.13 <sup>2</sup>	3.58 <sup>2</sup>	1.02	1.71	1/2-13
MILLIMETERS	10-12 <sup>2</sup>	4.53	4.53	F16	6.40	2.15	3.86 <sup>2</sup>	1.38	1.97 <sup>2</sup>	5/8-11
	65 - 100	89.9	47.5	—	—	44.5	78.7	17.0	27.9	1/2-13
	150	85.6	85.6	F12	121.0	40.9	90.9	25.9	43.5	1/2-13
	200	85.6	85.6	F12	121.0	54.0	90.9	25.9	43.5	1/2-13
	250-300	115.0	115.0	F16	162.6	54.6	98.0	35.0	50.0	5/8-11

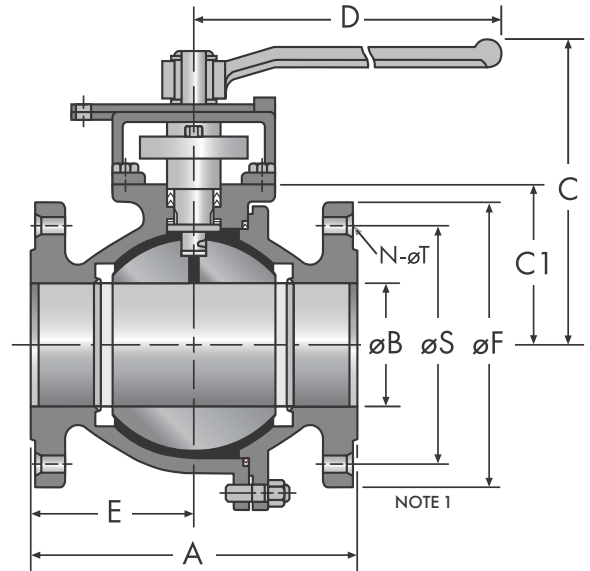

**Model F15 – Class 150**

	Size	A	øB	C	C1	D	E	øF	øS	N / øT	C <sub>v</sub>	Torque*	Weight
INCHES	2-1/2	7.50	2.56	6.63	3.39	15.35	3.08	7.00	5.50	4 x 0.75	780	500	36
	3	8.00	2.99	6.92	3.66	15.35	3.74	7.50	6.00	4 x 0.75	1,150	650	45
	4	9.00	3.99	7.59	4.39	15.35	4.47	9.00	7.50	8 x 0.75	2,100	1,505	65
	6	15.50	5.98	12.38	7.17	15.35	7.62	11.00	9.50	8 x 0.88	5,000	3,250	157
	8	18.00	7.87	12.66	7.60	38.98	8.35	13.50	11.75	8 x 0.88	9,600	4,750	290
	10	21.00	9.84	14.80	9.88	38.98	10.47	16.00	14.25	12 x 1.00	15,000	13,700	500
MILLIMETERS	12	24.00	11.81	16.37	11.46	38.98	12.01	19.00	17.00	12 x 1.00	21,000	19,700	700
	65	190.5	65.0	168.40	86.0	389.9	78.0	177.8	139.7	4 x 19.0	675	56	16
	80	203.0	76.0	175.65	93.0	389.9	95.0	190.5	152.0	4 x 19.0	995	73	20
	100	228.6	101.0	192.90	111.5	389.9	113.5	228.6	190.5	8 x 19.0	1,817	170	29.5
	150	393.7	151.9	314.55	182.0	389.9	193.6	279.0	241.0	8 x 22.0	4,325	367	71
	200	457.0	199.9	321.58	193.0	990.0	212.0	342.9	298.5	8 x 22.0	8,304	537	132
	250	533.0	249.9	375.85	251.0	990.0	265.9	406.0	362.0	12 x 25.0	12,975	1,548	227
300	609.6	300.0	415.85	291.0	990.0	305.0	482.6	431.8	12 x 25.0	18,165	2,226	318	

**Model F30 – Class 300**

	Size	A	øB	C	C1	D	E	øF	øS	N / øT	C <sub>v</sub>	Torque*	Weight
INCHES	2-1/2	9.50	2.56	6.55	3.39	15.35	4.18	7.50	5.88	8 x 0.88	780	600	44
	3	11.12	2.99	6.85	3.72	15.35	5.57	8.25	6.62	8 x 0.88	1,150	850	61
	4	12.00	3.99	7.56	4.35	15.35	5.96	10.00	7.88	8 x 0.88	2,100	2,600	96
	6	15.88	5.98	12.37	7.19	38.98	7.60	12.50	10.62	12 x 0.88	5,000	5,300	243
	8	19.75	7.87	13.82	8.64	38.98	9.33	15.00	13.00	12 x 1.00	9,600	7,600	430
	10	22.38	9.84	-	9.69	38.98	11.18	17.50	15.25	16 x 1.12	15,000	17,800	610
MILLIMETERS	12	25.50	11.81	-	11.26	38.98	12.80	20.50	17.75	16 x 1.25	21,000	24,800	950
	65	241.0	65.0	166.40	86.0	389.9	106.0	190.5	149.0	8 x 22.0	675	68	20
	80	282.5	76.0	173.90	94.5	389.9	141.5	209.6	168.0	8 x 22.0	995	96	27.7
	100	304.8	101.0	192.05	110.5	389.9	151.0	254.0	200.0	8 x 22.0	1,817	294	44
	150	403.0	151.9	314.20	182.6	990.0	193.0	317.5	269.8	12 x 22.0	4,325	599	110
	200	501.7	199.9	351.05	219.5	990.0	237.0	381.0	330.0	12 x 25.0	8,304	859	195
	250	568.5	249.9	-	246.0	990.0	284.0	444.5	387.0	16 x 28.5	12,975	2,011	277
300	647.7	300.0	-	286.0	990.0	325.0	520.7	450.9	16 x 31.8	18,165	2,802	431	

<sup>1</sup> For 8" F30: K=1.61, L=3.42

<sup>2</sup> For 10" F30: L=3.82, P=2.165

NOTE 1: Ball Support as shown on Page 3 is included on 6"-12" F15 and 6"-12" F30 valves.

NOTE 2: 2½", 3" & 4" valves feature a NAMUR stem slot for ease of limit switch mounting.

**Face to Face** dimensions meet ASME B16.10 long pattern in all sizes and short pattern sizes up to 4" F15 and up to 6" F30.

\***Torque** at maximum rated pressure, clean water, TFM 1600 seating material. Other seat materials exhibit different torques.

Please refer to TB 1005 for specific torques.

SINCE 1986, BRAY HAS PROVIDED FLOW CONTROL SOLUTIONS FOR A VARIETY OF INDUSTRIES AROUND THE WORLD.

VISIT **BRAY.COM** TO LEARN MORE ABOUT BRAY PRODUCTS AND LOCATIONS NEAR YOU.

## **HEADQUARTERS**

**Bray International, Inc.**

13333 Westland East Blvd.

Houston, Texas 77041

Tel: +1.281.894.5454

All statements, technical information, and recommendations in this bulletin are for general use only. Consult Bray representatives or factory for the specific requirements and material selection for your intended application. The right to change or modify product design or product without prior notice is reserved. Patents issued and applied for worldwide. Bray® is a registered trademark of Bray International, Inc.

© 2021 BRAY INTERNATIONAL. ALL RIGHTS RESERVED. BRAY.COM

EN\_F-2400\_F15/F30\_20210825

---



**THE HIGH PERFORMANCE COMPANY**

**BRAY.COM**