

FLOW-TEK

TRUNNION MOUNTED BALL VALVES



BRAY.COM/FLOW-TEK

Flow-Tek[®]
Subsidiary of BRAY INTERNATIONAL, Inc.

FEATURES AND BENEFITS

1 Emergency Stem Sealant Injection

This standard feature allows the valve's stem housing to be adapted with a grease fitting to inject sealant during emergency scenarios. By filling the cavity between the stem and stem housing, this secondary stem seal provides protection against unplanned spikes in operating conditions.

2 Emergency Seat Sealant Injection

This optional feature allows the valve's end connections to be adapted with a grease fitting to inject sealant. This creates a positive seal in the case of seat leakage due to service impurities or unplanned spikes in operating conditions.

3 Drain and Vent Ports

Drain ports located at the bottom of the valve allow for elimination of any fluid trapped in the body cavity of a closed valve. Vent ports located at the top of the body cavity allow for elimination of any gas trapped in the body cavity of a fully closed valve. Both play a key safety role in a double block and bleed and double isolation and bleed valve configurations.

4 Double Block and Bleed

This valve configuration provides the safety feature of eliminating any high pressure media that is trapped in the valve's body cavity. This pressure relief system is versatile, allowing the pressure buildup to be eliminated while the valve is in the fully closed position. Additionally, periodic seat integrity tests can be performed.

5 Firesafe Design

Secondary metal seat design provides a firesafe shut off per API 607. Additionally, secondary graphite body seals and flexible graphite packing prevents leakage through the body joints and stuffing box, respectively.

6 Internal Trunnion Design

Upper and lower bearing plates hold the ball in place. This compact design prevents the ball from floating axially, avoiding excess load on the seats. Additionally, external trunnion design available in certain sizes.

7 Pressure Energized Stem Packing

The proprietary energizer ring located above the primary o-ring stem seal provides insurance in the rare occasion the o-ring is damaged. The energizer ring would use the media pressure to create an upward compressive force on the packing. This upward force on the packing is combined with the downward compressive force created by tightening the packing gland. This results in a larger net compressive force on the packing and better seal than a typical packing design.

8 Double Seals on Body Joints

Primary elastomeric seals ensure zero leakage in standard operating conditions. Secondary graphite seals ensure proper body joint sealing per API 607 in extreme temperature scenarios.

9 Anti-Static Devices

Anti-static devices are provided as standard. These devices ensure electrical continuity between the ball, stem, and body, eliminating the possibility of static electrical charges creating sparks within the valve.

10 Valve Position Indication

Clear stamping on the outer diameter of the mounting flange identifies the open or closed position of the valve, based on the stem key orientation.

11 ISO 5211 Mounting Pad

Robust ISO 5211 mounting pad provides quick conversion between the valve and the automation package.

12 Blowout-proof Stem Design

Valves are designed with stem/body connection preventing stem blowout under line pressure.

TECHNICAL SPECIFICATIONS

Size Range*	2" - 24" (50mm - 600mm)	
Class Rating*	ASME Class 150, 300, 600	
Temperature Range	-50 to 600°F (-45 to 315°C)	
Port	Full	
Construction	2 piece, 3 piece	
Body Material*	ASTM A105 ASTM A350 Gr. LF2 ASTM A182 Gr F316	
Ball Material*	ASTM A105 w/ENP ASTM A350 Gr. LF2 w/ENP ASTM A182 Gr F316	
Seat Material*	RPTFE	PEEK
	Nylon	Tek-Fil
	Devlon	TFM
End Connections	Flanged, Butt Weld	

*Additional sizes, pressure classes, and materials available upon request

STANDARDS & CERTIFICATIONS

Design Standard	API 6D, ASME B16.34, PED 2014/68/EU
Flanges	ASME B16.5
BW Ends	ASME B16.25
Testing	API 6D
Fire Safety	API 607
NACE	MR-0175 Compatible
Fugitive Emissions	ISO 15848-1

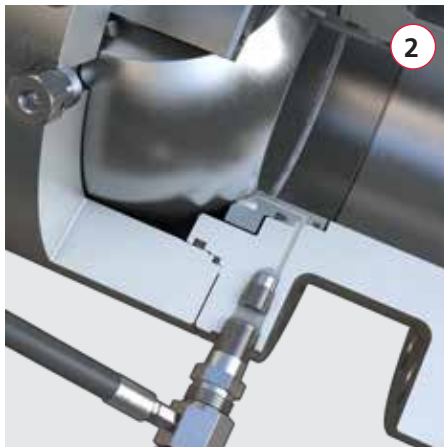
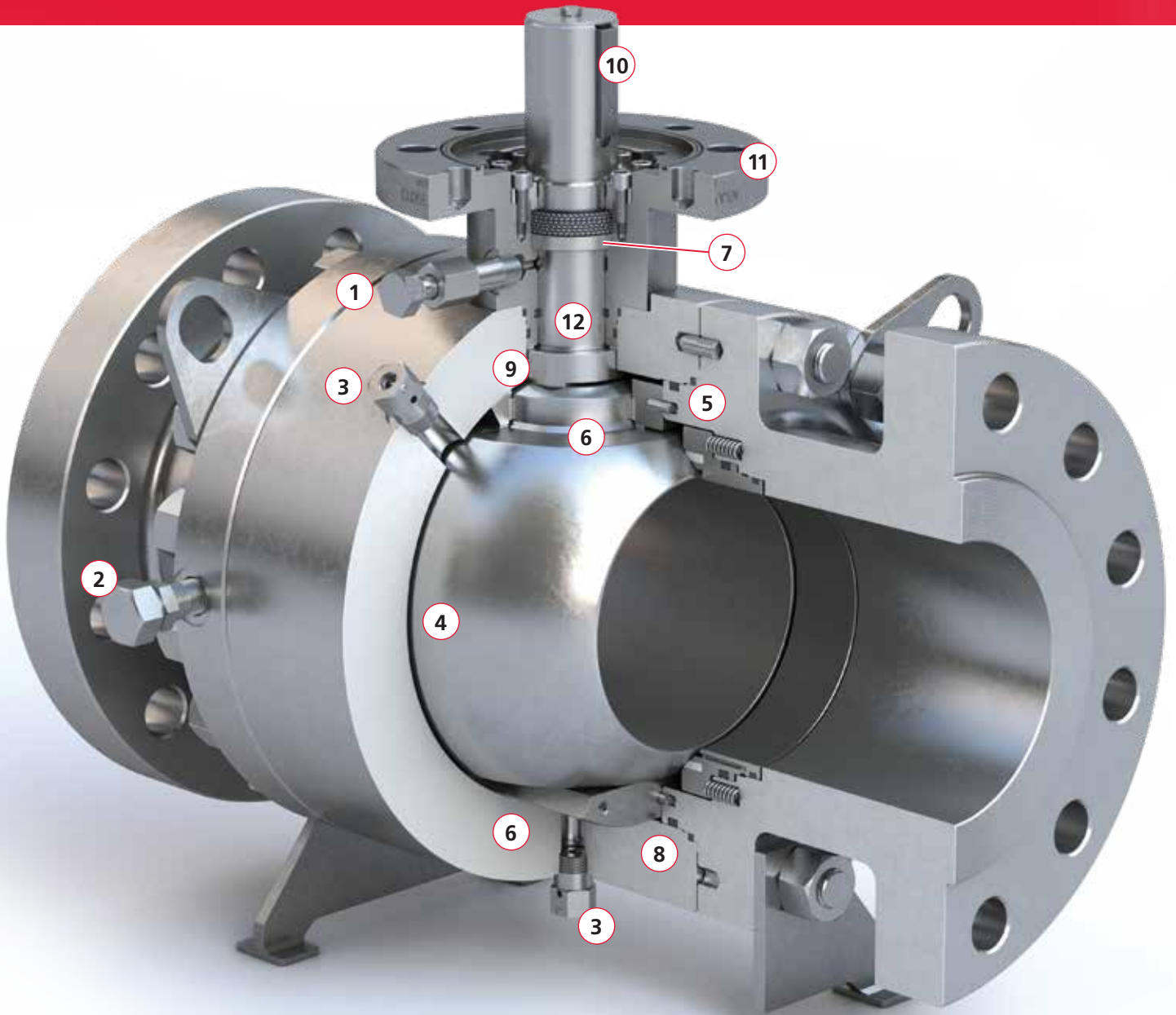

SEAT CONFIGURATION

Type A

Primary Seat – Metal

Secondary Seat – Soft Material

Generally suited for larger valve sizes, services containing light solids, and critical service requiring double seal assurance.



Type B

Primary Seat – Soft Material

Standard style typically suited for smaller valve sizes and general services.



DESIGN FEATURES

Single Piston Effect

With this design, pressurized media upstream of the seat results in a force pushing the seat toward the ball. As temperatures rise, media trapped inside the body cavity builds up excessive pressure. This pressure pushes the seat away from the ball, compresses the seat springs, and allows the media to relieve past the seat. This self-relieving seat design allows for safe operation without the need for dedicated bleed lines.

Single Piston Upstream Pressure

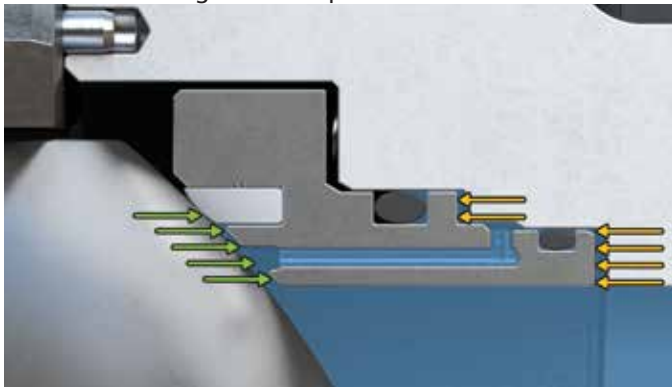

Double Piston Effect

This seat design uses pressure on both sides of the seat to assist sealing. As seen below, pressurized media upstream of the seat results in a force pushing the seat toward the ball. Similarly, when the pressurized media is inside the body cavity, the resulting force pushes the seat toward the ball. This sealing effect doesn't allow for self-relieving of cavity pressure and, in turn, requires a bleed line be installed within the body cavity. This type of valve configuration is valuable in applications where two redundant seals are required in the same direction (e.g. when repairs are being made downstream in a toxic service line). If media were to get past the upstream seal, dangerous flow toward the technician would be blocked by the downstream seal and evacuated by the bleed line.

Double Piston Upstream Pressure

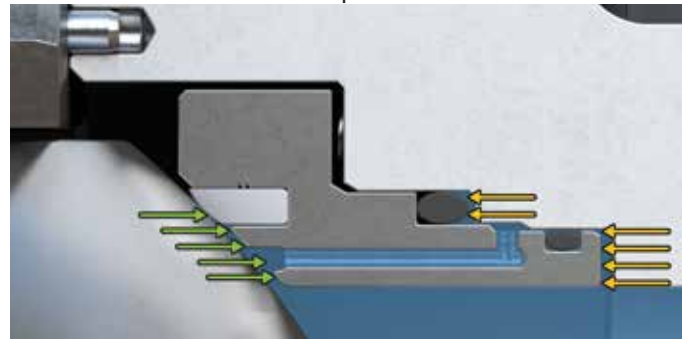

Single Piston Internal Cavity Pressure

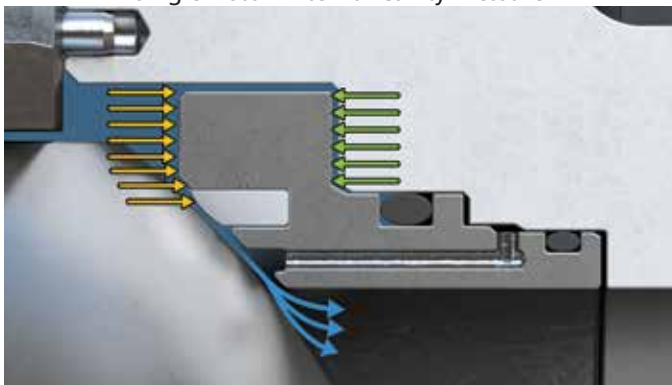

Double Piston Internal Cavity Pressure

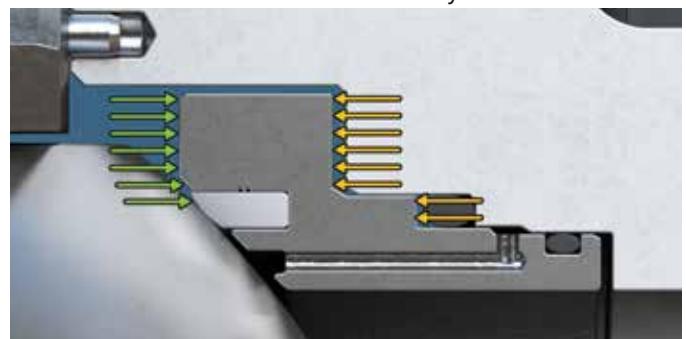

PRESSURE TEMPERATURE CHART

TMBV Series Pressure-Temperature Ratings

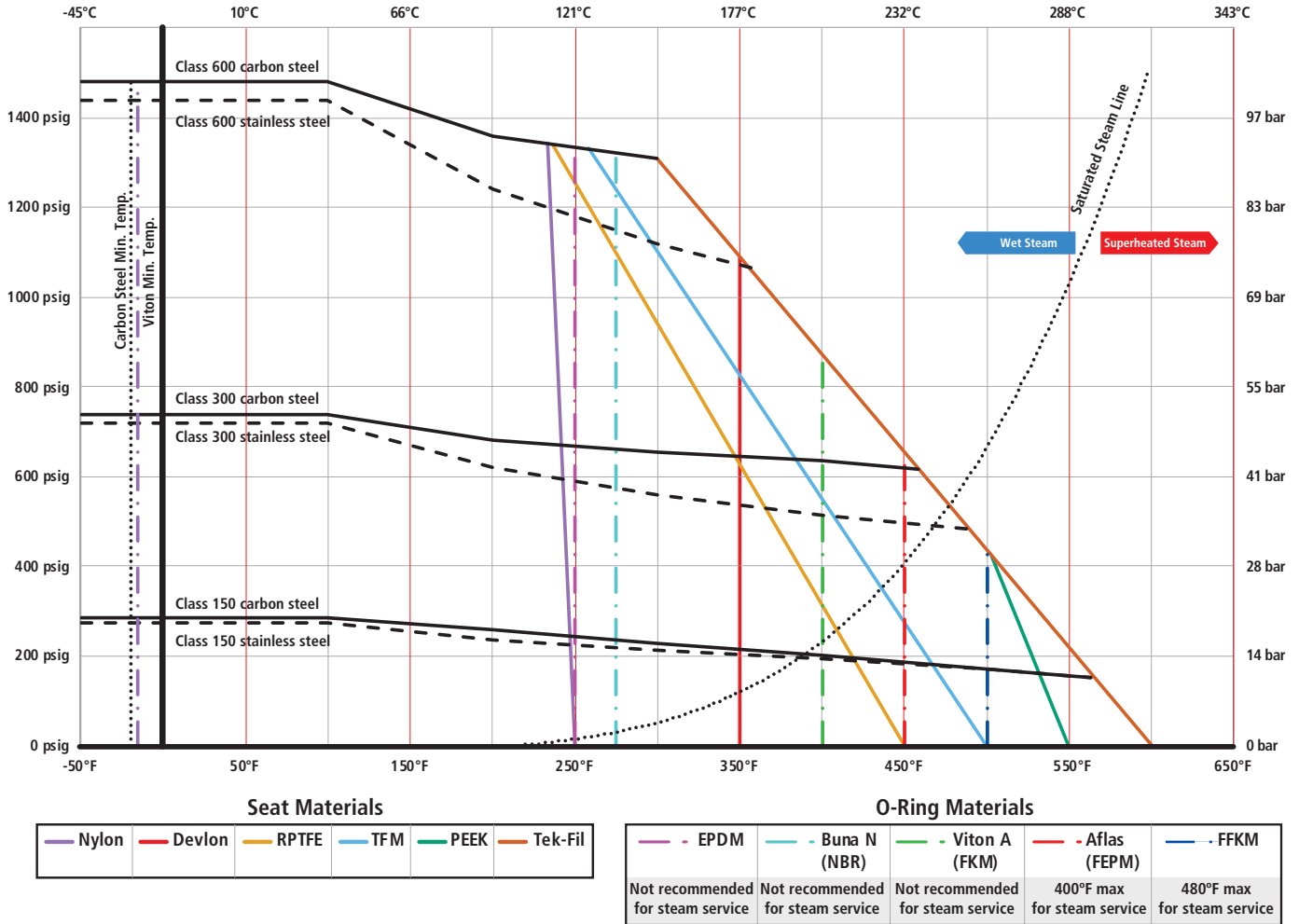

APPLICATIONS

- Oil and Gas Pipeline
- Offshore Platforms
- Onshore Terminals
- Emergency Shutdown
- Suction and Discharge Isolation
- Block and Bypass
- Pumping, Compression and ReInjection Units
- Metering Stations
- Pig Traps
- Surge-Relief Skids
- Decoking Isolation
- Buried Services
- Produced Water (Brine) Services



BILL OF MATERIALS

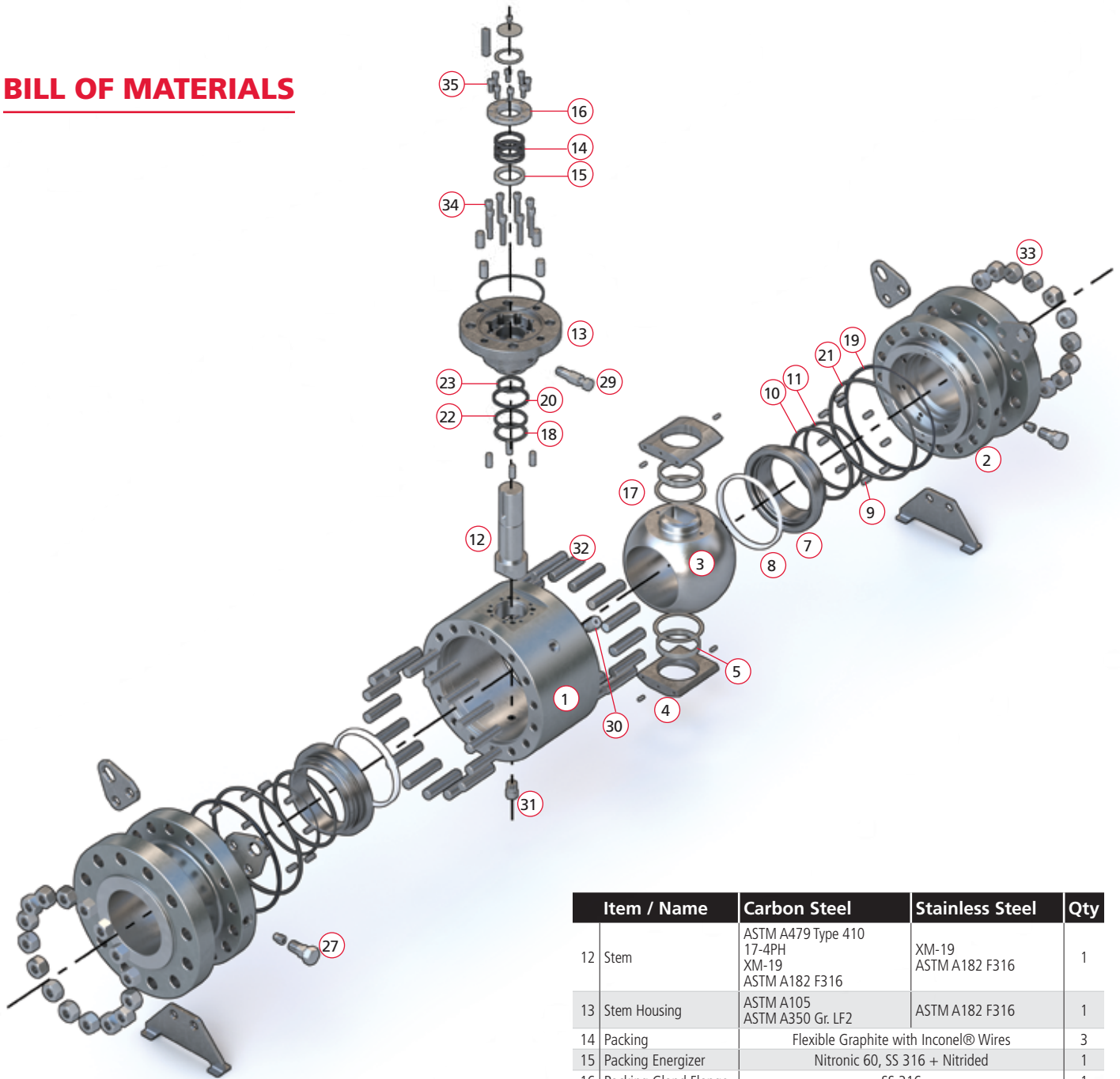

Item / Name	Carbon Steel	Stainless Steel	Qty
1 Body	ASTM A105 ASTM A350 Gr. LF2	ASTM A182 F316	1
2 End Connection	ASTM A105 ASTM A350 Gr. LF2	ASTM A182 F316	1 or 2
3 Ball	ASTM A105 w/ENP ASTM A350 Gr. LF2 w/ENP ASTM A182 Gr. F316 ASTM A182 Gr. F316 w/ENP	ASTM A182 F316 ASTM A182 F316 w/ENP	1
4 Bearing Retainer	ASTM A516 Gr.70 ASTM A216 Gr.WCB ASTM A352 Gr.LCB	ASTM A240 Gr. 316 ASTM A351 Gr. CF8M	2
5 Bearing (Ball Trunnion)	Steel Backed Composite	Stainless Steel Backed Composite	2
7 Seat Holder	ASTM A105 w/ENP ASTM A350 Gr. LF2 w/ENP ASTM A182 Gr. F316 ASTM A182 Gr. F316 w/ENP	ASTM A182 F316 ASTM A182 F316 w/ENP	2
8 Seat Insert	RPTFE, Nylon, Devlon, PEEK, Tek-Fil, TFM		2
9 Spring (Seat Holder)	Inconel X750		*
10 O-Ring (Seat Holder)	NBR, Viton		2
11 O-Ring (Seat Holder)	NBR, Viton		2

Item / Name	Carbon Steel	Stainless Steel	Qty
12 Stem	ASTM A479 Type 410 17-4PH XM-19 ASTM A182 F316	XM-19 ASTM A182 F316	1
13 Stem Housing	ASTM A105 ASTM A350 Gr. LF2	ASTM A182 F316	1
14 Packing	Flexible Graphite with Inconel® Wires		3
15 Packing Energizer	Nitronic 60, SS 316 + Nitrided		1
16 Packing Gland Flange	SS 316		1
17 Thrust Washer (Ball)	Steel Backed Composite	Stainless Steel Backed Composite	2
18 Thrust Washer (Stem)	Steel Backed Composite	Stainless Steel Backed Composite	1
19 Seal (Body)	Graphite		*
20 Seal (Stem Housing)	Graphite		1
21 O-Ring (End Connection)	NBR, Viton		*
22 O-Ring (Stem Housing)	NBR, Viton		1
23 O-Ring (Stem)	NBR, Viton		1
27 Sealant Injector (End Connection)	Stainless Steel	Carbon Steel	*
29 Sealant Injector (Stem Housing)	Stainless Steel	Carbon Steel	1
30 Vent Plug	Stainless Steel	Carbon Steel	2
31 Drain Plug	Stainless Steel	Carbon Steel	1
32 Stud - Body	ASTM A193 Gr B7/B7M	ASTM A193 Gr B8M	*
33 Nut - Body	ASTM A194 Gr 2H/2HM	ASTM A194 Gr 8M	*
34 Socket Head Cap Screw (Stem Housing)	ASTM A193 Gr B7/B7M	ASTM A193 Gr B8M	*
35 Socket Head Cap Screw (Gland)	ASTM A193 Gr B7/B7M	ASTM A193 Gr B8M	*

Additional materials (including cast metals) available on request.
*Quantity depends on valve size.

DIMENSIONS

Size: 2"-4"

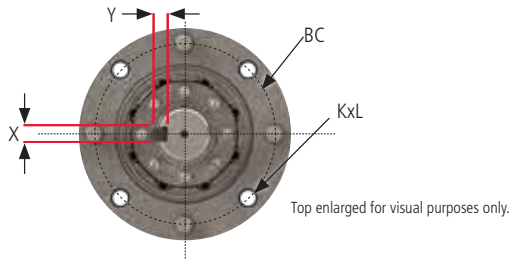

Size: 6"-24"

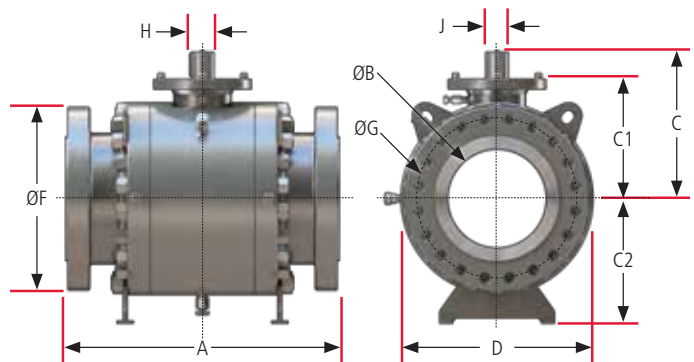
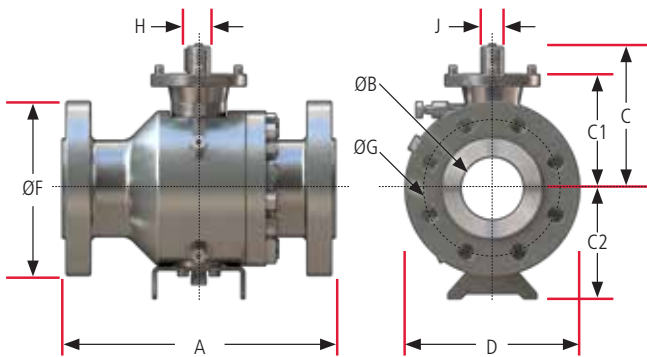
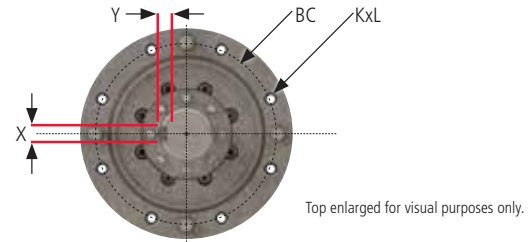

CLASS 150 VALVE DIMENSIONS (in/mm)

Size NPS DN	Valve						Valve Flange			Top Works							Weight LB kg	Cv Full Open	Valve Torque Max** Lb-in Nm	
	A	ØB	C	C1	C2	D	ØF	ØG	N NO OF HOLES	H With Key	J	BC	K	L NO OF HOLES	MTG CODE	X* Key				Y* Key
2 50	7.01 178	1.93 49	6.61 168	5.31 135	4.57 116	6.38 162	6.02 153	4.75 120.7	4	0.63 16	0.87 22	4.02 102	0.43 11	4	F10	-	-	49 22	462	682 77
3 80	7.99 203	2.91 74	7.52 191	5.55 141	5.12 130	7.48 190	7.48 190	6.00 152.4	4	0.87 22	1.18 30	4.02 102	0.43 11	4	F10	-	-	73 33	1107	1620 183
4 100	9.02 229	3.94 100	9.25 235	7.09 180	6.10 155	9.45 240	9.06 230	7.50 190.5	8	1.54 39.2	1.38 35	4.92 125	0.51 13	4	F12	0.39 10	0.39 10	123 56	2091	2522 285
6 150	15.51 394	5.91 150	11.57 294	9.25 235	8.35 212	12.52 318	11.02 280	9.50 241.3	8	1.91 48.5	1.77 45	6.50 165	0.83 21	4	F16	0.55 14	0.35 9	227 103	4918	5195 587
8 200	17.99 457	7.91 201	13.66 347	10.63 270	10.12 257	15.63 397	13.58 345	11.75 298.5	8	2.13 54.1	1.97 50	6.50 165	0.83 21	4	F16	0.47 12	0.39 10	562 255	9105	8001 904
10 250	20.98 533	9.92 252	15.20 386	12.17 309	12.83 326	18.58 472	15.94 405	14.25 362.0	12	2.13 54.1	1.97 50	6.50 165	0.83 21	4	F16	0.47 12	0.39 10	869 394	14645	11683 1320
12 300	24.02 610	11.93 303	16.69 424	13.58 345	14.72 374	21.77 553	19.09 485	17.00 431.8	12	2.44 62.0	2.28 58	6.50 165	0.83 21	4	F16	0.63 16	0.39 10	1325 601	21566	16604 1876
14 350	27.01 686	13.15 334	17.76 451	14.65 372	15.75 400	23.70 602	21.06 535	18.75 476.3	12	2.44 62.0	2.28 58	6.50 165	0.83 21	4	F16	0.63 16	0.39 10	1691 767	26458	24455 2763
16 400	30.00 762	15.16 385	20.20 513	16.65 423	17.28 439	27.01 686	23.43 595	21.25 539.8	16	2.76 70.2	2.50 63.5	10.00 254	0.67 17	8	F25	5/8 15.88	5/8 15.88	2425 1100	35644	34518 3900
18 450	34.02 864	17.17 436	21.46 545	17.95 456	18.74 476	30.08 764	25.00 635	22.75 577.9	16	2.93 74.5	2.76 70	10.00 254	0.67 17	8	F25	0.79 20	0.47 12	3192 1448	46262	44873 5070
20 500	35.98 914	19.17 487	24.21 615	19.92 506	20.51 521	33.23 844	27.56 700	25.00 635.0	20	3.32 84.4	3.00 76.2	10.00 254	0.67 17	8	F25	3/4 19.05	3/4 19.05	4193 1902	58328	58645 6626
24 600	42.01 1067	23.19 589	28.46 723	23.23 590	23.23 590	39.29 998	32.09 815	29.50 749.3	20	4.31 109.4	4.00 101.6	11.73 298	0.83 21	8	F30	1 25.4	3/4 19.05	6609 2998	86853	88906 10045

Dimensions provided are for reference. Please contact factory for additional or more specific information

*Valve sizes without key dimensions shown in the table utilize a double "D" style stem. Please contact factory for detailed dimensions.

**Valve torques mentioned above do not contain a safety factor and are not applicable to PEEK seated valves. Please refer to Technical Bulletin 1005 for more detailed information.

CLASS 300 VALVE DIMENSIONS (in/mm)

Size NPS DN	Valve						Valve Flange			Top Works							Weight LB kg	Cv Full Open	Valve Torque Max** Lb-in Nm	
	A	ØB	C	C1	C2	D	ØF	ØG	N NO OF HOLES	H With Key	J	BC	K	L NO OF HOLES	MTG CODE	X* Key				Y* Key
2 50	8.5 216	1.93 49	7.05 179	5.08 129	5.04 128	6.5 165	6.5 165	5 127	8	0.87 22	1.18 30	4.02 102	0.43 11	4	F10	-	-	49 22	462	903 102
3 80	11.14 283	2.91 74	8.43 214	6.3 160	5.71 145	8.27 210	8.27 210	6.63 168.3	8	1.54 39.2	1.38 35	4.92 125	0.51 13	4	F12	0.39 10	0.39 10	73 33	1107	2177 246
4 100	12.01 305	3.94 100	8.98 228	7.09 180	6.1 155	10.04 255	10.04 255	7.87 200	12	1.54 39.2	1.38 35	4.92 125	0.51 13	4	F12	0.39 10	0.39 10	123 56	2091	3452 390
6 150	15.87 403	5.91 150	11.57 294	9.25 235	8.39 213	12.6 320	12.6 320	10.63 269.9	16	1.91 48.5	1.77 45	6.5 165	0.83 21	4	F16	0.55 14	0.35	227 103	4918	7638 863
8 200	19.76 502	7.91 201	13.66 347	10.63 270	10.28 261	15.63 397	14.96 380	13 330.2	20	2.13 54.1	1.97 50	6.5 165	0.83 21	4	F16	0.47 12	0.39 10	562 255	9105	12258 1385
10 250	22.36 568	9.92 252	15.28 388	12.17 309	12.99 330	18.9 480	17.52 445	15.25 387.4	24	2.44 62	2.28 58	6.5 165	0.83 21	4	F16	0.63 16	0.39 10	869 394	14645	17533 1981
12 300	25.51 648	11.93 303	17.64 448	14.09 358	14.69 373	22.13 562	20.47 520	17.75 450.8	12	2.76 70.2	2.5 63.5	10 254	0.67 17	8	F25	5/8 15.88	5/8 15.88	1325 601	21566	23915 2702
14 350	30 762	13.14 334	18.31 465	14.84 377	15.63 397	24.06 611	23.03 585	20.25 514.4	12	2.93 74.5	2.76 70	10 254	0.67 17	8	F25	0.79 20	0.47 12	1691 767	26458	36200 4090
16 400	32.99 838	15.16 385	21.18 538	16.93 430	17.36 441	27.4 696	25.59 650	22.5 571.5	16	3.32 84.4	3 76.2	10 254	0.67 17	8	F25	3/4 19.05	3/4 19.05	2425 1100	35644	54875 6200
18 450	35.98 914	17.17 436	23.5 597	18.54 471	19.13 486	30.79 782	27.95 710	24.75 628.6	16	3.75 95.3	3.5 88.9	11.73 298	0.83 21	8	F30	7/8 22.23	5/8 15.88	3192 1448	46262	74045 8366
20 500	39.02 991	19.17 487	25.24 641	20.12 511	20.67 525	33.82 859	30.51 775	27 685.8	20	4.31 109.4	4 101.6	11.73 298	0.83 21	8	F30	1 25.4	3/4 19.05	4193 1902	58328	100279 11330
24 600	45 1143	23.19 589	31.3 795	24.72 628	23.94 608	40.47 1028	36.02 915	32 812.8	20	4.82 122.4	4.5 114.3	14.02 356	1.22 31	8	F35	1 25.4	3/4 19.05	6609 2998	86853	141939 16037

CLASS 600 VALVE DIMENSIONS (in/mm)

Size NPS DN	Valve						Valve Flange			Top Works							Weight LB kg	Cv Full Open	Valve Torque Max** Lb-in Nm	
	A	ØB	C	C1	C2	D	ØF	ØG	N NO OF HOLES	H With Key	J	BC	K	L NO OF HOLES	MTG CODE	X* Key				Y* Key
2 50	11.5 292	1.93 49	7.05 179	5.08 129	5.04 128	6.5 165	6.5 165	5 127	8	0.87 22	1.18 30	4.02 102	0.43 11	4	F10	-	-	64 29	462	1221 138
3 80	14.13 359	2.91 74	8.43 214	6.3 160	5.71 145	8.27 210	8.27 210	6.63 168.3	8	1.54 39.2	1.38 35	4.92 125	0.51 13	4	F12	0.39 10	0.39 10	123 56	1107	3054 345
4 100	17.01 432	3.94 100	9.02 229	7.09 180	6.5 165	10.83 275	10.83 275	8.5 215.9	12	1.54 39.2	1.38 35	4.92 125	0.51 13	4	F12	0.39 10	0.39 10	223 101	2091	4248 480
6 150	22.01 559	5.91 150	12.48 317	9.45 240	9.02 229	13.98 355	13.98 355	11.5 292.1	16	2.13 54.1	1.97 50	6.5 165	0.83 21	8	F16	0.47 12	0.39 10	569 258	4918	12099 1367
8 200	25.98 660	7.91 201	14.21 361	11.02 280	10.83 275	16.61 422	16.54 420	13.75 349.2	20	2.44 62	2.28 58	6.5 165	0.83 21	8	F16	0.63 16	0.39 10	933 423	9105	18551 2096
10 250	30.98 787	9.92 252	16.54 420	12.99 330	13.74 349	20.08 510	20.08 510	17 431.8	24	2.76 70.2	2.5 63.5	10 254	0.67 17	8	F25	5/8 15.88	5/8 15.88	1581 717	14645	27703 3130
12 300	32.99 838	11.93 303	17.83 453	14.37 365	15 381	23.15 588	22.05 560	19.25 489	16	2.93 74.5	2.76 70	10 254	0.67 17	4	F25	0.79 20	0.47 12	2172 985	21566	38032 4297
14 350	35 889	13.15 334	20.16 512	15.91 404	16.46 418	25.43 646	23.82 605	20.75 527	20	3.32 84.4	3 76.2	10 254	0.67 17	4	F25	3/4 19.05	3/4 19.05	2793 1267	26458	57158 6458
16 400	39.02 991	15.16 385	22.64 575	17.68 449	17.95 456	28.82 732	26.97 685	23.75 603.2	20	3.75 95.3	3.5 88.9	11.73 298	0.83 21	8	F30	7/8 22.23	5/8 15.88	3929 1782	35644	87799 9920
18 450	42.99 1092	17.17 436	24.53 623	19.41 493	20 508	32.6 828	29.33 745	25.75 654	24	4.31 109.4	4 101.6	11.73 298	0.83 21	8	F30	1 25.4	3/4 19.05	5463 2478	46262	120813 13650
20 500	47.01 1194	19.17 487	28.78 731	22.2 564	21.18 538	35.63 905	32.09 815	28.5 723.9	24	4.82 122.4	4.5 114.3	14.02 356	1.22 31	8	F35	1 25.4	3/4 19.05	6850 3107	58328	167456 18920
24 600	55 1397	23.19 589	32.95 837	25.98 660	26.46 672	42.52 1080	37.01 940	33 838.2	24	5.35 135.9	5 127	14.02 356	1.22 31	8	F35	1 1/4 31.75	7/8 22.23	11356 5151	86853	224119 25322

Dimensions provided are for reference. Please contact factory for additional or more specific information.

*Valve sizes without key dimensions shown in the table utilize a double "D" style stem. Please contact factory for detailed dimensions.

**Valve torques mentioned above do not contain a safety factor and are not applicable to PEEK seated valves. Please refer to Technical Bulletin 1005 for more detailed information.

Flow-Tek®

Subsidiary of BRAY INTERNATIONAL, Inc.

8323 N. Eldridge Pkwy. #100

Houston, Texas 77041

Tel: 832.912.2300 • Fax: 832.912.2301

bray.com/flow-tek

All statements, technical information, and recommendations in this bulletin are for general use only. Consult Flow-Tek representatives or factory for the specific requirements and material selection for your intended application. The right to change or modify product design or product without prior notice is reserved.

Flow-Tek® is a registered trademark of Bray International, Inc.

© 2019 Bray International, Inc. All rights reserved.

F-2811 TMBValves 06-2019

