



AMERICAN Specials

The principal standards relating to AMERICAN Specials are ANSI/AWWA C110/A21.10, C151/A21.51, and C153/A21.53. These and other standards are referenced throughout this Section either by the full ANSI/AWWA designation or by only the AWWA numbering, such as AWWA C110.

In addition to the full complement of Mechanical Joint (MJ), Fastite®, Restrained Joint, and Flanged fittings, AMERICAN furnishes many special fittings to meet special construction requirements. AMERICAN Specials include types and lengths of wall pipe, wall castings and fabrications, fittings with a combination of joints, and a number of other special fittings. Many of the special fittings furnished by AMERICAN are included in this section.

General Notes Relating to AMERICAN Specials

1. Fittings are manufactured of ductile iron, grade 70-50-05 (minimum tensile strength: 70,000 psi; minimum yield strength: 50,000 psi; minimum elongation: 5%) in accordance with AWWA C110 or C153.
2. Pipes are manufactured of ductile iron, grade 60-42-10, (minimum tensile strength: 60,000 psi; minimum yield strength: 42,000 psi; minimum elongation: 10%) in accordance with AWWA C151.
3. Flange adaptors for AWWA C110/C115 Flange to ANSI/ASME B16.1 Class 250 Flange are manufactured of ASTM A36 steel.
4. Flanges and static-cast MJ bells can be tapped for studs when specified by the purchaser.
5. All pressure ratings shown are AMERICAN's suggested standard and are for water service.
6. Unless otherwise noted, all cast-on flanges are per AWWA C110 or C153.
7. All Mechanical Joints comply with AWWA C111. Threaded-on or otherwise fabricated MJ bells are per applicable portions of AWWA C115 and C153. Weights of MJ accessories are not included in weights of fittings with MJ outlets shown in tables, unless otherwise specified.
8. Weights of fittings can vary due to changes in foundry practice.
9. AMERICAN produces many specials other than those listed in this section. Contact AMERICAN regarding any specific requirements.



**AMERICAN Ductile Iron Specials
Plain End Pipe and Thrust Collar Weights
Fabricated Wall Pipe**

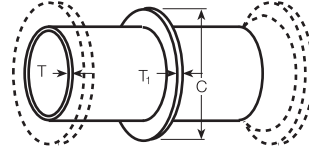

Table No. 7-1

Size in.	Plain End Pipe				Thrust Collars			
	Ductile Iron Centrifugally Cast				T1 Thickness in.	C Diameter in.	Weight lb	Allowable Load † Per Collar T lbs
	ANSI/AWWA* Minimum Class	Weight lb/ft	ANSI/AWWA** C115	Weight lb/ft				
T lbs Thickness in.		T lbs Thickness in.						
4	.25	10.9	.32	13.8	.25	6.80	1	4,500
6	.25	16.0	.34	21.4	.25	8.90	2	9,300
8	.25	21.1	.36	30.1	.25	11.05	2	16,000
10	.26	27.1	.38	39.2	.25	13.10	3	24,000
12	.28	34.8	.40	49.2	.25	15.20	3	34,000
14	.28	40.4	.42	60.1	.25	17.30	5	46,000
16	.30	49.3	.43	70.1	.25	19.40	6	59,000
18	.31	57.2	.44	80.6	.38	22.50	15	75,000
20	.33	67.5	.45	91.5	.38	24.60	11	92,000
24	.33	80.8	.47	114.4	.38	28.80	13	130,000
30	.34	103.5	.51	154.4	.50	36.00	29	200,000
36	.38	138.5	.58	210.3	.50	42.30	35	290,000
42	.41	173.8	.65	274.0	.75	50.75	98	390,000
48	.46	222.6	.72	346.6	.75	57.05	111	510,000
54	.51	279.7	.81	441.9	1.00	66.06	231	650,000
60	.54	317.0	.83	485.0	1.00	70.11	246	745,000
64	.56	350.5	.87	542.0	1.00	74.17	261	847,000

*AWWA C151 – minimum thickness classes in this standard are Class 350 for 4”–12” sizes, Class 250 for 14”–20” sizes, Class 200 for 24” and Class 150 for 30”–64” sizes.

**AWWA C115 – minimum thicknesses for all sizes of ductile iron pipe for threading on flanges.

Wall pipe is normally fabricated of Special Class 53 thickness ductile iron pipe but may be furnished with minimum classes unless threaded flanges or threaded MJ bells are included or unless specified otherwise. For weights of plain end pipe of other classes see Section 3, Table No. 3–9.

†These values are based on dead-end thrust due to 250 psi internal pressure. For higher allowable loads or pressures, contact AMERICAN. (See also the figure above Table No. 9–11, for use of thrust collars, e.g., in some buried systems where other types of concrete thrust blocks cannot be used.)

Welded-on thrust collars are normally fabricated from steel. Dimensions and weights above are for steel thrust collars.

Collars may be angled and/or rotated from top dead center. Contact AMERICAN for details.

See general notes on page 7–1.



**AMERICAN Ductile Iron Specials
Bell and Flange Weights**

Table No. 7-2

Size in.	Bells—Weight in Pounds					Flanges—Weight in Pounds	
	Mechanical Joint		Fastite	Flex-Ring	Lok-Ring	ANSI/AWWA** Flange	ANSI B16.1 F&D Class 250
	Centrifugally Cast On Pipe*	Threaded- On Pipe	Centrifugally Cast On Pipe*	Centrifugally Cast On Pipe*	Centrifugally Cast On Pipe*	Threaded- On C115	Threaded- On
4	14	16	7	14	—	12	22
6	19	23	12	20	—	17	32
8	25	31	19	29	—	24	51
10	31	41	29	40	—	36	69
12	38	55	31	54	—	55	100
14	—	85	40	92	—	70	125
16	—	105	45	105	—	80	145
18	—	125	72	125	—	85	200
20	—	150	80	130	—	105	220
24	—	235	96	222	—	160	335
30	—	375	164	328	—	240	514
36	—	500	210	428	—	350	697
42	—	600	315	609	—	500	994
48	—	810	389	778	—	625	1510
54	—	—	515	—	667	664	—
60	—	—	569	—	805	1055	—
64	—	—	677	—	866	1765	—

*Bell weights for ductile iron pipe are the same for all pressure classes per AWWA C151.

**AWWA C110 flange and AWWA C115 flange will match with facing and drilling of ANSI B16.1 Class 125 flange.

In sizes where applicable.

A unique Fastite fitting bell is not available in many configurations of 4"–48" fittings. In cases where Flex-Ring bell fittings are used without Flex-Ring or Field Flex-Ring restraint (in effect as "Fastite") the Flex-Ring "Statically Cast" bell weight will of course apply.

Weights shown for 14" and larger AWWA C110 cast-on flanges are for Class B thickness statically cast pipe and fittings; for a Class D thickness casting the cast-on flange weight is lighter by approximately 5% to 15% with the lower of these percentages applicable to the smaller size fittings and the higher of the percentages to the larger size fittings.

Weights above are subject to change, our option.

See General Notes on page 7-1.

To determine weight of wall pipe, use data in Table Nos. 7-1 and 7-2. For example: Weight of 12" Flg-W/S-MJ Wall Pipe with centrifugal cast bell 12" L.L.(14 1/2" O.A.) Special Class 53 equals (12"/12" X 49.2 lb/ft.) + 58 lbs (Flg) + 10 lbs (W/S) + 38 lbs (MJ Bell) = 155 lbs.



AMERICAN Ductile Iron Specials Thrust Collar (T/C) Wall Pipe - Fabricated from Centrifugally Cast Ductile Iron Pipe

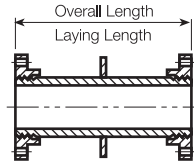

Flange-Thrust Collar-Flange

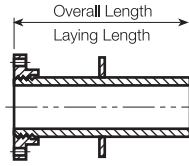

Flange-Thrust Collar-Plain End

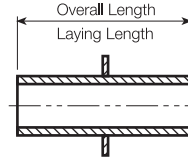

Plain End-Thrust Collar-Plain End

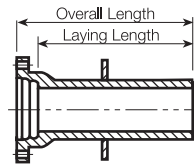

MJ-Thrust Collar-Plain End

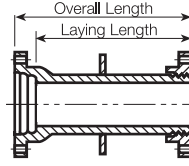

MJ-Thrust Collar-Flange

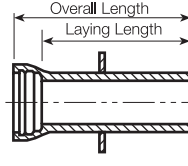

Fastite-Thrust Collar-Plain End

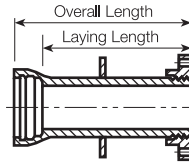

Fastite-Thrust Collar-Flange

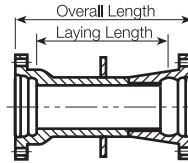

MJ-Thrust Collar-MJ Fab

Table No. 7-3

Size in.	Minimum Dimensions in Inches													
	Fig-T/C-Flg.	Fig-T/C-PE	Fig-T/C-PE	MJ-T/C-MJ (Fab*)		MJ-T/C-PE		MJ-T/C-Flg		Fst-T/C-PE		Fst-T/C-Flg		
	O.A./L.L.	O.A./L.L.	O.A./L.L.	O.A.	L.L.	O.A.	L.L.	O.A.	L.L.	O.A.	L.L.*	O.A.	L.L.*	
4	8	8	8	10	4 ⁵ / ₈	8	5 ¹ / ₂	8	5 ¹ / ₂	8	4 ¹¹ / ₁₆	8	4 ⁵ / ₈	
6	8	8	8	10	4 ⁵ / ₈	8	5 ¹ / ₂	8	5 ¹ / ₂	8	4 ⁵ / ₈	8	4 ⁵ / ₈	
8	8	8	8	10	4 ⁵ / ₈	8	5 ¹ / ₂	8	5 ¹ / ₂	8	4 ¹ / ₄	8	4 ¹ / ₄	
10	8	8	8	10	4 ⁵ / ₈	8	5 ¹ / ₂	10	7 ¹ / ₂	8	4 ¹ / ₄	7 ¹ / ₄	3 ¹ / ₂	
12	8	8	8	10	4 ⁵ / ₈	8	5 ¹ / ₂	10	7 ¹ / ₂	8	4 ¹ / ₄	7 ¹ / ₄	3 ¹ / ₂	
14	8 ¹ / ₂	8	8	12	4 ¹ / ₂	8	4 ¹ / ₂	11	7 ¹ / ₂	8	2 ³ / ₄	9 ³ / ₄	4 ¹ / ₂	
16	8 ¹ / ₂	8	8	12	4 ¹ / ₂	8	4 ¹ / ₂	11 ¹ / ₂	8	8	2 ³ / ₄	9 ³ / ₄	4 ¹ / ₂	
18	8 ¹ / ₂	8	8	12	4 ¹ / ₂	8	4 ¹ / ₂	12	8 ¹ / ₂	8	1 ¹ / ₂	10	4 ¹ / ₂	
20	8 ¹ / ₂	8	8	12	4 ¹ / ₂	8	4 ¹ / ₂	12	8 ¹ / ₂	8	1 ¹ / ₂	10	4 ¹ / ₂	
24	9 ¹ / ₂	8	8	12	4 ¹ / ₂	8	4 ¹ / ₂	12	8 ¹ / ₂	8	1 ¹ / ₂	10	4 ¹ / ₂	
30	12	10 ¹ / ₂	8	-	-	-	-	-	-	8	1 ¹ / ₂	12	5 ¹ / ₂	
36	14	11 ¹ / ₂	8	-	-	-	-	-	-	8	1 ¹ / ₂	12	5 ¹ / ₂	
42	16	12	8	-	-	-	-	-	-	8 ¹ / ₂	1	14	6 ¹ / ₂	
48	16	12	8	-	-	-	-	-	-	9	1	15	7	
54	18	16	8	-	-	-	-	-	-	9 ¹ / ₂	1	16	7 ¹ / ₂	
60	18	16	8	-	-	-	-	-	-	9 ³ / ₄	1	16	7 ¹ / ₄	
64	18	16	8	-	-	-	-	-	-	10	1	16	7	

*Laying lengths are rounded to the nearest 1/4".
Thrust Collars may not be located in exact center of all minimum length pieces shown above.

Flanges and MJ bells of minimum-length pieces should normally be specified by the purchaser "lapped for studs" to enable assembly of joints flush with the wall face.

Maximum laying length of above wall pipe is 19'-6" (except 19'-0" for 64") except for MJ-T/C-PE or Fst-T/C-PE which may be furnished full 20' nominal length in all available sizes with the exception of 4" (4" maximum length is 18'-1 3/4"). 4"-16" Flange-Thrust Collar-Flange and Flange-Thrust Collar - PE pipe may also be furnished up to 20'-0" length. Contact AMERICAN if longer lengths required. All intermediate lengths can be furnished.

Wall pipe lengths shorter than those shown above can be furnished in some sizes by special fabrication. Contact AMERICAN for details.

Overall lengths are subject to manufacturing tolerances. If maximum overall length is critical, such as for installation of item inside steel forms, this must be specified by the purchaser on the order.

To determine weight of Thrust Collars Wall Pipe, use data in Table 7-1. Correctly installed flanged wall pipe will normally have the bolt holes straddling the horizontal and vertical centerlines. **Checking with a spirit level or plumb line prior to pouring the walls is recommended.**

Wall pipe with MJ threaded-on bells (MJ Fab), Flex-Ring, and Lok-Ring bells can also be furnished. Contact AMERICAN for dimensions not shown above.

Minimum-length pipes with plain ends (PE) in many cases do not allow enough room between PE and collar to assemble joints. Contact AMERICAN for PE joint assembly needs, normally requiring longer pipes.



AMERICAN Ductile Iron Specials
Wall Piping - Recommended Minimum Installation
Dimensions for Piping not Tapped for Studs

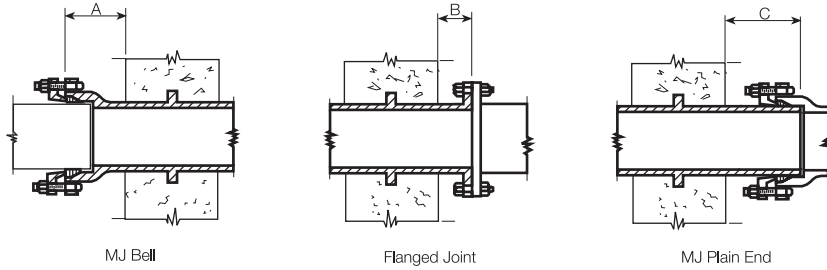

Table No. 7-4

Size in.	A in.	B in.	C in.
4	5 ³ / ₄	2 ¹ / ₄	6
6	5 ³ / ₄	2 ³ / ₄	6
8	6 ¹ / ₄	2 ³ / ₄	6 ¹ / ₂
10	6 ¹ / ₂	3	6 ¹ / ₂
12	6 ¹ / ₂	3	6 ¹ / ₂
14	7	3 ¹ / ₂	7 ³ / ₄
16	7 ¹ / ₄	3 ¹ / ₂	7 ³ / ₄
18	7 ¹ / ₂	3 ³ / ₄	7 ³ / ₄
20	7 ¹ / ₂	3 ³ / ₄	7 ³ / ₄
24	8	4	8 ¹ / ₄
30	9 ¹ / ₂	5	9 ³ / ₄
36	9 ³ / ₄	5 ¹ / ₄	9 ³ / ₄
42	10	*5 ¹ / ₂	10
48	10	*6	10
54	–	*6 ¹ / ₄	–
60	–	*6 ¹ / ₂	–
64	–	*6 ³ / ₄	–

*The minimum dimension "B" for 42"–64" wall castings with threaded-on (AWWA C115) flange would be as follows: for 42", B = 6"; for 48", B = 6¹/₂"; for 54"–64", B = 7¹/₄".

Dimensions are based on standard mechanical joints per AWWA C111 and standard flanges per AWWA C110.

Wall piping with MJ bells or flanges having "A" and "B" dimensions shorter than those above, e.g. wall pipes with bell faces often placed "flush" with concrete form work, should be specified to be tapped for studs.

"A" and "C" dimensions for 14"–48" sizes apply to MJ castings only.



AMERICAN DUCTILE IRON PIPE

**AMERICAN Ductile Iron Specials
AMERICAN Fabricated Mechanical Joint Pipe
ANSI/AWWA C151/A21.51, C153/C21.53, and AMERICAN Standard**

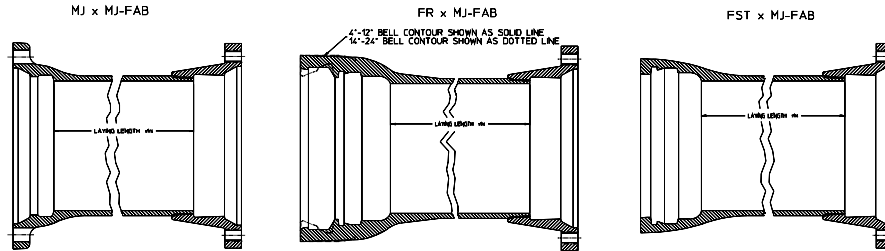

Table No. 7-5

Size in.	Pressure Rating psi	Nominal Wall Thickness in.	Pipe O.D. in.	Fastite and MJ-Fab		MJ and MJ-Fab		Flex-Ring and MJ-Fab				
				Laying Length		Weight (Max.LL)*	Laying Length		Weight (Max.LL)*	Laying Length		Weight (Max.LL)*
				Min. in.	Max ft.in.	Length lb	Min. in.	Max ft. in.	Length lb	Min. in.	Max ft.in.	Length lb
4	350	.32	4.80	2 ¹⁵ / ₁₆	19'6"	325	4	19'6"	295	2 ¹⁴ / ₁₆	19'6"	295
6	350	.34	6.90	3 ¹ / ₈	19'6"	460	4	19'6"	460	2 ¹⁴ / ₁₆	19'6"	460
8	350	.36	9.05	4 ³ / ₄	19'6"	645	6	19'6"	645	3 ³ / ₄	19'6"	645
10	350	.38	11.10	4 ³ / ₄	19'6"	840	6	19'6"	840	2 ³ / ₄	19'6"	840
12	350	.40	13.20	5 ³ / ₄	19'6"	1055	6	19'6"	1055	3 ³ / ₄	19'6"	1055
14	350	.42	15.30	4 ¹ / ₄	19'6"	1315	7	19'6"	1315	3 ¹ / ₈	19'6"	1315
16	350	.43	17.40	5 ¹ / ₄	19'6"	1545	5	19'6"	1545	5 ¹ / ₈	19'6"	1545
18	350	.44	19.50	5	19'6"	1785	6	19'6"	1785	4 ⁵ / ₁₆	19'6"	1785
20	350	.45	21.60	6	19'6"	2030	6	19'6"	2030	5 ⁵ / ₁₆	19'6"	2030
24	350	.47	25.80	7	19'6"	2585	11	19'6"	2470	6 ¹ / ₂	19'6"	2585

Pipe is available with greater wall thicknesses than shown. Thicknesses above correspond to Special Thickness Class 53.
Any length between minimum and maximum shown can be furnished.
Tolerance on length is ± .25".
Socket depths for Threaded-on MJ Bells (MJ-Fab) are 2.88" for 4"-12" sizes and 4" for 14"-24" sizes.
* For 4"-24" sizes 19'-6".



AMERICAN Ductile Iron Specials

AMERICAN Flange Adaptor for AWWA C110/C115 Flange to ASME B16.1 Class 250# Flange AMERICAN Standard

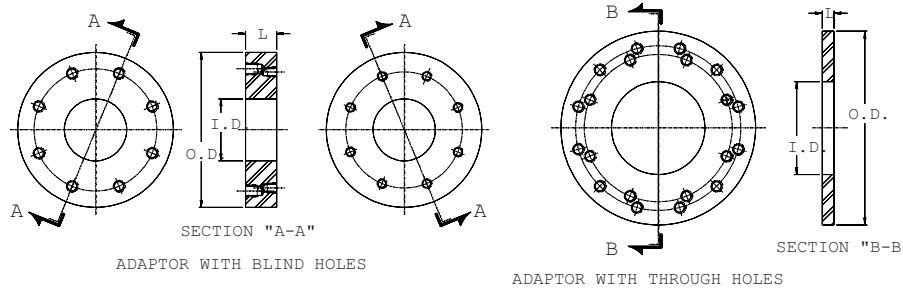

Table No. 7-6

Size in.	Outside Diameter in.	Inside Diameter in.	Length "L" in.	Tap Depth		Weight lb
				C115 Flange in.	B16.1 Class 250 Flange in.	
4	10.00	4.00	2	3/4	7/8	37
6	12.50	6.00	1	Through	Through	27
8	15.00	8.00	1	Through	Through	36
10	17.50	10.00	2 1/2	7/8	1	115
12	20.50	12.00	2 1/2	7/8	1 1/8	154
14	23.00	14.00	2 1/2	1	1 1/8	186
16	25.50	16.00	2 3/4	1	1 1/4	242
18	28.00	18.00	2	Through	Through	205
20	30.50	20.00	3	1 1/8	1 1/4	355
24	36.00	24.00	3 1/4	1 1/4	1 1/2	522
30	43.00	30.00	2 1/2	Through	Through	529
36	50.00	36.00	4	1 1/2	2	1141
42	57.00	42.00	4	1 1/2	2	1408
48	65.00	48.00	3	Through	Through	1285

Material is ASTM A36 steel.
 Holes are drilled and tapped to mate with AWWA C110/C115 flanges on one side and ANSI/ASME B16.1 Class 250 flanges on the opposite, or other side.
 Holes are equally spaced straddling centerline.
 12"-30" flange adaptors and 36"-48" flange adaptors are tapped at top dead center for 5/8" and 3/4" (5/8-11 UNC and 3/4-10 UNC threaded) lifting eyes, respectively.



AMERICAN Ductile Iron Specials
Flange and Flare
90° Bends

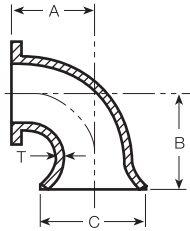

Short Radius

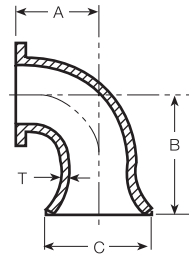

Long Radius

Table No. 7-7

Size	T	C	Short Radius 90 Degree Flare Bends			Long Radius 90 Degree Flare Bends		
			A	B	Wt.	A	B	Wt.
4	0.52	9.00	6.50	12.00	45	9.00	14.50	50
6	0.55	11.00	8.00	12.00	75	11.50	15.50	90
8	0.60	13.50	9.00	14.00	120	14.00	19.00	155
10	0.68	16.00	11.00	17.00	195	16.50	22.50	250
12	0.75	19.00	12.00	18.00	275	19.00	25.00	375
14	0.66	21.00	14.00	21.50	310	21.50	29.00	400
16	0.70	23.50	15.00	23.00	395	24.00	32.00	530
18	0.75	25.00	16.50	25.00	495	26.50	35.00	675
20	0.80	27.50	18.00	27.00	630	29.00	38.00	865
24	0.89	32.00	22.00	32.50	995	34.00	44.50	1335
30	1.03	38.75	25.00	36.00	1970	41.50	48.50	2190
36	1.15	46.00	28.00	38.00	2730	49.00	56.00	3465
42	1.28	53.00	31.00	35.00	3200	56.50	63.50	5150
48	1.42	59.50	34.00	46.00	5235	64.00	71.00	6725

* 54" and 60" castings have wall thicknesses that are per AWWA C153. All other wall thicknesses are per C100.

** Contact AMERICAN for 64" Flare dimensions.

Since above fittings are not included in AWWA C110, A, B, and C dimensions above should be specified on engineering drawings.

Other joints can be furnished in lieu of flanges in some sizes.

See general notes on page 7-1.



AMERICAN Ductile Iron Specials Flare† Castings

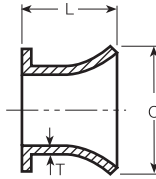

Flange and Flare

Table No. 7-8

Size in.	Pressure Rating psi	Dimensions in Inches				Weight in Lbs (Min. Length)
		T	L Minimum	L Maximum	C	Flg & Flare
4	250	.52	8	8	9.00	40
6	250	.55	8	8	11.00	65
8	250	.60	10	10	13.50	105
10	250	.68	10	10	16.00	145
12	250	.75	12	12	19.00	210
14	250	.66	12	36	21.00	240
16	250	.70	14	36	23.50	310
18	250	.75	14	36	25.00	370
20	250	.80	13	36	27.50	435
24	250	.89	18	66	32.00	680
30	250	1.03	15	66	38.75	960
36	250	1.15	14	66	46.00	1265
42	250	1.28	12	72	53.00	1260
48	250	1.42	18	72	59.50	2375

† This fitting is sometimes referred to as "bell mouth."

* 54" and 60" castings have wall thicknesses that are per AWWA C153. All other wall thicknesses are per AWWA C100.

** Contact AMERICAN for 64" Flare dimensions.

Flare castings or fabrications can be furnished in a variety of lengths and with wall collars when specified. Flange or mechanical joint bell to be installed flush with the wall should be specified "tap for studs."

The addition of a wall collar to flare castings may affect the minimum length of the casting.

Other joints can be furnished in lieu of flanges or MJ bells in most sizes.

Since above fittings are not included in AWWA C110, L and C dimensions above should be specified on engineering drawings.

See general notes on page 7-1.



AMERICAN Ductile Iron Specials Outlet/Tapping Saddles

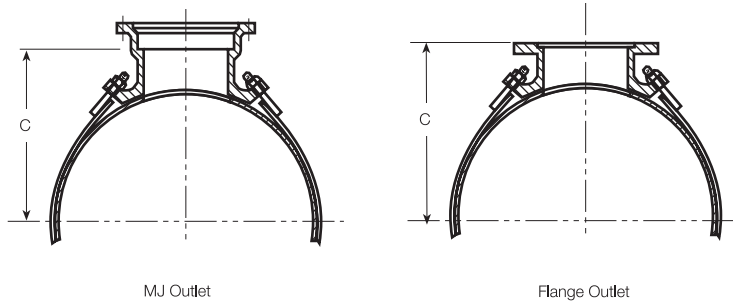

A saddle is furnished with AWWA C110 flange or mechanical joint outlet and can be installed on pipe with hole already machine cut, or torch cut at shop or job site. Saddle can thus be used on 12"–54" pipe for providing outlet as pipeline is being installed or in pipeline already installed. For a saddle in sizes 4"–12" with AWWA C110 flange connection on the branch, the flange is counterbored per MSS (Manufacturers' Standardization Society) SP-60 dimensions, making assembly possible with a tapping machine, tapping valve or a stan-

ard C110 flange. The inside diameter of the outlet is 1/4" greater than the nominal, enabling a full-size opening to be made in pipe wall. Counterbore dimensions are as tabulated below in Table No. 7-13.

Size of Flange in.	Counterbore	
	Depth in.	Diameter in.
4	.250	5.015
6	.312	7.015
8	.312	9.015
10	.312	11.015
12	.312	13.015

Table No. 7-9

Size in.	O.D. of Parent Pipe in.	C in.	No. of Straps	Weight in Pounds		
				Saddle Casting	Straps & Nuts	Total
12 x 4	13.20	12.85	3	45	15	60
12 x 6	13.20	12.85	3	62	14	75
14 x 4	15.30	13.90	3	45	17	60
14 x 6	15.30	13.90	3	62	16	80
16 x 4	17.40	14.95	3	45	19	65
16 x 6	17.40	14.95	3	62	18	80
16 x 8	17.40	14.95	4	89	24	115
18 x 4	19.50	16.00	3	45	22	65
18 x 6	19.50	16.00	3	62	21	85
18 x 8	19.50	16.00	4	89	26	115
20 x 4	21.60	17.05	3	45	23	170
20 x 6	21.60	17.05	3	62	23	185
20 x 8	21.60	17.05	4	89	29	120
20 x 10	21.60	17.05	5	120	35	155
24 x 4	25.80	19.15	3	45	27	70
24 x 6	25.80	19.15	3	62	27	90
24 x 8	25.80	19.15	4	89	35	125
24 x 10	25.80	19.15	5	120	42	160
24 x 12	25.80	19.15	7	151	58	210

See notes at end of Table.



AMERICAN Ductile Iron Specials Outlet/Tapping Saddles

Table No. 7-9—Continued

Size in.	O.D. of Parent Pipe in.	C in.	No. of Straps	Weight in Pounds		
				Saddle Casting	Straps & Nuts	Total
30 x 4	32.00	22.00	3	45	34	80
30 x 6	32.00	22.00	3	62	34	95
30 x 8	32.00	22.00	4	89	43	130
30 x 10	32.00	22.00	5	120	53	175
30 x 12	32.00	22.00	7	151	72	225
36 x 4	38.30	25.25	3	45	40	185
36 x 6	38.30	25.25	3	62	40	100
36 x 8	38.30	25.25	4	89	52	140
36 x 10	38.30	25.25	5	120	64	185
36 x 12	38.30	25.25	7	151	88	240
42 x 4	44.50	28.25	3	45	46	190
42 x 6	44.50	28.25	3	62	46	110
42 x 8	44.50	28.25	4	89	60	150
42 x 10	44.50	28.25	5	120	74	195
42 x 12	44.50	28.25	7	151	102	255
48 x 4	50.80	31.50	3	145	53	100
48 x 6	50.80	31.50	3	162	52	115
48 x 8	50.80	31.50	4	189	69	160
48 x 10	50.80	31.50	5	120	85	205
48 x 12	50.80	31.50	7	151	117	270
54 x 4	57.56*	34.55	3	145	59	105
54 x 6	57.56*	34.55	3	162	58	120
54 x 8	57.56*	34.55	4	189	77	165
54 x 10	57.56*	34.55	5	120	95	215
54 x 12	57.56*	34.55	7	151	132	285

Weights are for saddle with MJ bell or AWWA C110 flange; weights do not include any MJ or flange joint materials. Saddles listed are rated 250 psi working pressure. Contact AMERICAN for higher pressure applications.
 Straps are alloy steel, 1/4" X 1 1/2" in cross section and are fabricated with 3/4" threaded ends. Sealing of saddle is provided by a positively confined "O-Ring" SBR rubber gasket, circular in cross section and made of molded rubber approximately 70 durometer hardness.
 Saddles to fit some other diameters can be furnished upon request. Order should specify diameter of parent pipe. Outlet can be furnished tapped for studs when specified.
 Maximum size outlet normally furnished for tapping 12"-14" pipe is 6"; for 16"-18" pipe is 8"; for 20" pipe is 10"; and for 24"-54" pipe is 12".
 On special order some outlets 14" -18" can be furnished for low pressure service on 30"-54" pipe.
 See general notes on page 7-1.
 *Prior to 1988, 54" AMERICAN pipe had an O.D. of 57.10". Installers should measure the O.D. of existing 54" pipe prior to ordering so that proper strap lengths can be furnished.

For recommended minimum installation distance (X) from face of Fastite bell to center of saddle, see Table No. 7-10.

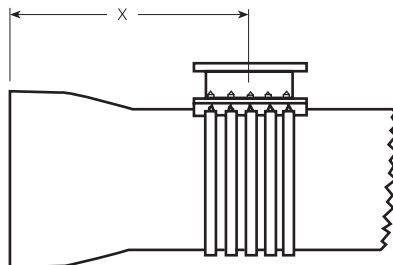

Table No. 7-10

Size in.	"X" Min.
12 x 6	12
14 x 6	14
16 x 8	14
18 x 8	16
20 x 10	16
24 x 12	18
30 x 12	18
36 x 12	18
42 x 12	20
48 x 12	20
54 x 12	20



AMERICAN Ductile Iron Specials Welded-on Outlets for Ductile Iron Pipe

AMERICAN regularly furnishes pipe with welded-on outlets for proven effectiveness and simplicity in layout and installation. Outlets can readily be located at variable positions along the pipeline, and rotation* of the pipe before it is assembled in the line can often position the outlet at any desired angle. This section provides detailed tabular data for 90° lateral and tangential welded-on outlets. Lateral outlets from 45°-90° in 15° increments from the parent pipe axis are also standardly available in some sizes with some additional outlet size restrictions. (Contact AMERICAN for details.)

JOINTS. The outlets are fabricated from centrifugally cast ductile iron pipe, manufactured and tested in accordance with ANSI/AWWA C151/A21.51. They may be furnished with any of AMERICAN's bell ends such as Fastite, MJ, Flex-Ring, or Lok-Ring. They can also be furnished with plain ends. The parent pipe can also be furnished with any type of joints.

THICKNESSES. Minimum nominal thicknesses for both parent and outlet pipe are shown in the following tables. The outlets are rated 200 to 250 PSI working pressure, depending on size, as noted in Table No. 7-11. Contact AMERICAN for higher pressure applications.

This is a shop fabricated product and is not intended for field fabrication. Welded-on outlets for ductile pipe are produced with qualified procedures and welders as per guidelines contained in ANSI/AWS D11.2, Guide for Welding Iron Castings. Joint materials are furnished with Fastite, MJ, Flex-Ring, and Lok-Ring bells. Parent and outlet pipe are normally furnished cement lined in accordance with ANSI/AWWA C104/A21.4. Contact AMERICAN if ends or linings other than cement linings are desired.

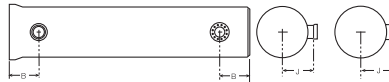

Table No. 7-11

Parent Pipe Diameter in.	Maximum Outlet Diameter** in.	Minimum Nominal Thickness Parent Pipe in.	Standard "J" Dimension† Center-Socket Bell Outlet in.	Standard "J" Dimension† Center-Face Flange Outlet in.	Outlet Diameter** in.	Minimum Nominal Thickness-Outlet Pipe in.	Rated Water Working Pressure of Outlet (psi)	Min. Distance Outlet to Parent Pipe End in. †B††
—	—	—	—	—	4	0.32	250	14-1/2
10	6	0.38	11	14-1/2	6	0.34	250	15-1/2
12	8	0.40	12	16	8	0.36	250	16-1/2
14	8	0.42	14	17	8	0.36	250	16-1/2
16	10	0.43	15	18	10	0.38	250	17-1/2
18	12	0.44	15-1/2	19-1/2	12	0.40	250	20
20	14	0.45	17	20-1/2	14	0.42	250	23
24	16	0.47	19	23	16	0.43	250	26
—	—	—	—	—	18	0.44	250	29
30	20	0.51	23	27	20	0.45	250	32-1/2
36	24	0.58	26	30-1/2	24	0.47	250	39
42	30	0.65	30	35	30	0.51	250	48
48	30	0.72	34	38-1/2	30	0.51	250	48
54	30	0.81	37	42	30	0.51	250	48
54	36	0.81	37	42	36	0.58	200	48
60	30	0.83	41	44	30	0.51	250	48
60	36	0.83	41	44	36	0.58	200	48
64	30	0.87	42	46	30	0.51	250	48
64	36	0.87	42	46	36	0.58	200	48

* Do not attempt to lift or rotate outlet pipes by attaching to or exerting force on the outlet or any branch piping attached thereto. Likewise, do not attach and suspend heavy piping items, etc., from outlet branch.

** The purpose of the 18" outlet diameter line is to provide this data when these standard outlets are applied on 30" and larger parent pipes only. Larger-diameter outlets may be available for some pressure and service applications. Contact AMERICAN for details.

† "J" dimensions are approximate and are the same for all different outlet sizes on a particular parent pipe size. Contact AMERICAN if different dimensions are required. Flanges used on outlets meet ASME B16.1 Class 125 requirements and may be welded on or threaded on.

†† Minimum "B" dimensions are dependent on outlet diameter and are not directly related to parent pipe diameter. For example, a "B" dimension for 6" outlets on all sizes of parent pipe (including 10") is 15 1/2", etc. Nominal thickness of 4"-54" diameter parent pipe and outlet pipe correspond to Special Class 53. Nominal thicknesses of

60" and 64" parent pipe correspond to Pressure Class 350 as shown in ANSI/AWWA C151/A21.51.

System design and installation should be such so as to avoid beam loads or impacts on the outlets. It is particularly important in underground service to use flexible joints (e.g., Flex-Ring or Fast-Grip) for outlet piping, to allow for at least some incidental movement between the parent and outlet piping. It should be noted that AWWA Manual M41 and the Appendix to ANSI/AWWA C115/A21.15 state that underground use of the flanged joint is generally not recommended because of the rigidity of the joint, and AMERICAN concurs with this guidance. Flexible outlet pipe joints should not be modified to make them rigid, nor should they be installed fully deflected.

This is a shop fabricated product and is not intended for field fabrication.

Contact AMERICAN for any applications of any flanged welded-on outlets involving connecting piping, such as pump suction and discharge headers, etc.



AMERICAN Ductile Iron Specials Tangential Welded-On Outlets for Ductile Iron Pipe

AMERICAN can furnish tangential welded-on outlets in certain diameters. Pipe with tangential outlets can often be positioned* with the outlets on bottom for blow offs or on top for air release. **Flanged and grooved joints are not available for tangential outlets.** Minimum pressure classes and location of outlets are the same as for regular welded-on outlets. This is a shop fabricated product and is not intended for field fabrication. Parent and outlet pipe are normally furnished cement lined in accordance with ANSI/AWWA C104/A21.4. Contact AMERICAN if ends or linings other than cement linings are desired.

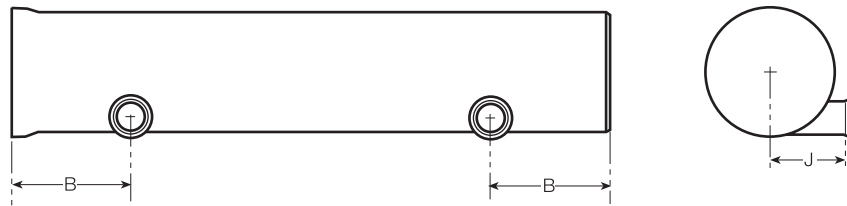

Table No. 7-12

Parent Pipe Diameter in.	Outlet Diameter in.	Minimum Nominal Thickness* Parent/Outlet Pipe in.	Rated Water Working Pressure psi	Minimum "B" Location Outlet to Parent Pipe End in.	Standard "J" Dimension Center to Socket in.
8	4	0.36/0.32	250	14-1/2	11-1/2
10	4	0.38/0.32	250	14-1/2	12-1/2
10	6	0.38/0.34	250	15-1/2	12-1/2
12	4	0.40/0.32	250	14-1/2	13-1/2
12	6	0.40/0.34	250	15-1/2	13-1/2
12	8	0.40/0.36	250	16-1/2	13-1/2
14	4	0.42/0.32	250	14-1/2	14
14	6	0.42/0.34	250	15-1/2	14-1/2
14	8	0.42/0.36	250	16-1/2	14-1/2
16	4	0.43/0.32	250	14-1/2	15
16	6	0.43/0.34	250	15-1/2	15-1/2
16	8	0.43/0.36	250	16-1/2	15-1/2
16	10	0.43/0.38	250	17-1/2	15-1/2
18	4	0.44/0.32	250	14-1/2	15-1/2
18	6	0.44/0.34	250	15-1/2	16-1/2
18	8	0.44/0.36	250	16-1/2	16-1/2
18	10	0.44/0.38	250	17-1/2	17
18	12	0.44/0.40	250	20	17
20	4	0.45/0.32	250	14-1/2	16
20	6	0.45/0.34	250	15-1/2	17
20	8	0.45/0.36	250	16-1/2	17-1/2
20	10	0.45/0.38	250	17-1/2	18
20	12	0.45/0.40	250	20	18
20	14	0.45/0.42	250	23	18

* Do not attempt to lift or rotate outlet pipes by attaching to or exerting force on the outlet or any branch piping attached thereto. Likewise, don't attach and suspend heavy piping items, etc., from outlet branch.



**AMERICAN Ductile Iron Specials
Tangential Welded-On Outlets
for Ductile Iron Pipe**

Table No. 7-12 - Continued

Parent Pipe Diameter in.	Outlet Diameter in.	Minimum Nominal Thickness* Parent/Outlet Pipe in.	Rated Water Working Pressure psi	Minimum "B" Location Outlet to Parent Pipe End in.	Standard "J" Dimension Center to Socket in.
24	4	0.47/0.32	250	14-1/2	17
24	6	0.47/0.34	250	15-1/2	18-1/2
24	8	0.47/0.36	250	16-1/2	19-1/2
24	10	0.47/0.38	250	17-1/2	20
24	12	0.47/0.40	250	20	20
24	14	0.47/0.42	250	23	20
24	16	0.47/0.43	250	26	20
30	4	0.51/0.32	250	14-1/2	18-1/2
30	6	0.51/0.34	250	15-1/2	20-1/2
30	8	0.51/0.36	250	16-1/2	21-1/2
30	10	0.51/0.38	250	17-1/2	22-1/2
30	12	0.51/0.40	250	20	23
30	14	0.51/0.42	250	23	23-1/2
30	16	0.51/0.43	250	26	23-1/2
30	18	0.51/0.44	250	29	23-1/2
30	20	0.51/0.45	250	32-1/2	23-1/2
36	4	0.58/0.32	250	14-1/2	20
36	6	0.58/0.34	250	15-1/2	22
36	8	0.58/0.36	250	16-1/2	24
36	10	0.58/0.38	250	17-1/2	25
36	12	0.58/0.40	250	20	25-1/2
36	14	0.58/0.42	250	23	26-1/2
36	16	0.58/0.43	250	26	26-1/2
36	18	0.58/0.44	250	29	26-1/2
36	20	0.58/0.45	250	32-1/2	26-1/2
36	24	0.58/0.47	250	39	26-1/2
42	4	0.65/0.32	250	14-1/2	21-1/2
42	6	0.65/0.34	250	15-1/2	23-1/2
42	8	0.65/0.36	250	16-1/2	25-1/2
42	10	0.65/0.38	250	17-1/2	27
42	12	0.65/0.40	250	20	28
42	14	0.65/0.42	250	23	28-1/2
42	16	0.65/0.43	250	26	29
42	18	0.65/0.44	250	29	29-1/2
42	20	0.65/0.45	250	32-1/2	29-1/2
42	24	0.65/0.47	250	39	30
42	30	0.65/0.51	250	48	30
48	4	0.72/0.32	250	14-1/2	22-1/2
48	6	0.72/0.34	250	15-1/2	25
48	8	0.72/0.36	250	16-1/2	27
48	10	0.72/0.38	250	17-1/2	28-1/2
48	12	0.72/0.40	250	20	30
48	14	0.72/0.42	250	23	31
48	16	0.72/0.43	250	26	31-1/2
48	18	0.72/0.44	250	29	32
48	20	0.72/0.45	250	32-1/2	32-1/2
48	24	0.72/0.47	250	39	33
48	30	0.72/0.51	250	48	34



AMERICAN Ductile Iron Specials
Tangential Welded-On Outlets
for Ductile Iron Pipe

Table No. 7-12 - Continued

Parent Pipe Diameter in.	Outlet Diameter in.	Minimum Nominal Thickness* Parent/Outlet Pipe in.	Rated Water Working Pressure psi	Minimum "B" Location Outlet to Parent Pipe End in.	Standard "J" Dimension Center to Socket in.
54	4	0.81/0.32	250	14-1/2	23-1/2
54	6	0.81/0.34	250	15-1/2	26
54	8	0.81/0.36	250	16-1/2	28-1/2
54	10	0.81/0.38	250	17-1/2	30
54	12	0.81/0.40	250	20	31-1/2
54	14	0.81/0.42	250	23	33
54	16	0.81/0.43	250	26	34
54	18	0.81/0.44	250	29	34-1/2
54	20	0.81/0.45	250	32-1/2	35-1/2
54	24	0.81/0.47	250	39	36
54	30	0.81/0.51	250	48	37-1/2
54	36	0.81/0.58	200	48	37-1/2
60	4	0.83/0.32	250	14-1/2	25
60	6	0.83/0.34	250	15-1/2	28
60	8	0.83/0.36	250	16-1/2	30-1/2
60	10	0.83/0.38	250	17-1/2	32
60	12	0.83/0.40	250	20	34
60	14	0.83/0.42	250	23	35
60	16	0.83/0.43	250	26	36
60	18	0.83/0.44	250	29	37
60	20	0.83/0.45	250	32-1/2	38
60	24	0.83/0.47	250	39	39
60	30	0.83/0.51	250	48	39-1/2
60	36	0.83/0.58	200	48	39-1/2
64	4	0.87/0.32	250	14-1/2	25-1/2
64	6	0.87/0.34	250	15-1/2	28-1/2
64	8	0.87/0.36	250	16-1/2	31
64	10	0.87/0.38	250	17-1/2	33
64	12	0.87/0.40	250	20	35
64	14	0.87/0.42	250	23	36-1/2
64	16	0.87/0.43	250	26	37-1/2
64	18	0.87/0.44	250	29	38-1/2
64	20	0.87/0.45	250	32-1/2	39-1/2
64	24	0.87/0.47	250	39	40-1/2
64	30	0.87/0.51	250	48	41-1/2
64	36	0.87/0.58	200	48	41-1/2

* Nominal thickness of 4"-54" diameter parent pipe correspond to Special Class 53. Nominal thickness of 60" and 64" parent pipe correspond to Pressure Class 350.



AMERICAN Ductile Iron Specials Ductile Iron Trenchless Pipe

By its nature, ductile iron pipe possesses tremendous columnar and tensile strength, which makes it a superior material for trenchless applications. AMERICAN offers two joints designed for use in direct jacking, trenchless pipeline replacement, pipe bursting, and microtunneling installation. Fastite joint push-bar pipe allows the Fastite Joint to be used in trenchless applications using direct jacking or pushing. Flex-Ring® joint pipe with its positive, flexible joint restraint has been used extensively in pipe pulling applications using horizontal directional drilling and some pipe bursting installation methods. With spigots ahead, the low profile Flex-Ring® assembles quickly and offers a smooth transition during pipe pull-back. AMERICAN offers a Flex-Ring® pulling bell assembly specifically designed for this installation method.



Pulling Bell

Push-Bar pipe employs an economical adaptation of the premier AMERICAN Fastite joint to transfer jacking loads from the pipe barrel directly to the face of the bell. It consists of a high-strength, alloy steel ring, the "push-bar," shop welded to the standard Fastite pipe spigot. This ring is made of the same material that has been used successfully in AMERICAN's Lok-Ring and other restrained joints for more than 40 years. A cushioning compression ring, made of compressible wood products, fits between the push-bar and the pipe bell for added assurance of load distribution. The pipe comes in standard 20' or less standard nominal laying lengths and carries the standard Fastite joint pressure ratings. During installation, Fastite joint push-bar pipe is jacked or pushed with the spigots ahead. This allows for any debris remaining from the pipe bursting or pipe jacking operation to flow smoothly over the bell of the Fastite joint.

Flex-Ring joint pipe and allowable pulling loads are covered in Tables 7-13 and 7-1. See above picture of Flex-Ring pulling bell assembly at left.

Cement-mortar lining per ANSI/AWWA C104/A21.4 and asphalt exterior coating per ANSI/AWWA C151/A21.51 are standard for Flex-Ring and push-bar pipe. Other linings and coatings are available for specific service conditions.



AMERICAN Ductile Iron Flex-Ring® Joint Pipe
Standard Dimensions and Pressure Ratings

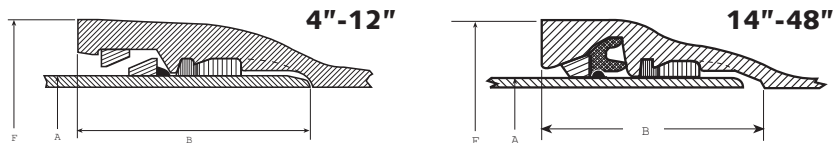

Table No. 7-13

4"-12"

Size in.	Working Pressure* psi	Nominal Laying Length** ft.	A O.D. in.	B Socket Depth in.	F Bell O.D.† in.	Allowable Pulling Load lb.††	Allowable Deflection degree	Offset per 20' Length in.	Radius of Curve^ ft.	Empty Pipe Buoyancy in Water (lb/ft)^^^
4	350	20	4.80	5.62	7.06	10,000	5	21	230	-5
6	350	20	6.90	5.62	9.19	20,000	5	21	230	-2
8	350	20	9.05	5.74	11.33	30,000	5	21	230	3
10	350	20	11.10	6.72	13.56	45,000	5	21	230	11
12	350	20	13.20	6.72	15.74	60,000	5	21	230	19

* Working pressure is the maximum pressure rating of the joint and is based on its capability to resist thrust due to internal pressure. If higher working pressure is required, contact AMERICAN.

** Laying length is nominal 20'. Where exact lengths are required, contact AMERICAN. Minimum laying lengths for Flex-Ring & Flex-Ring end pipe is 1'-0" and for Flex-Ring End & Flex-Ring end pipe is 2'-0".

† Dimensions subject to change at our option. Contact AMERICAN if smaller or exact dimensions are required.

†† Intended for horizontal directional drilling (HDD) applications. Flex-Ring pipe may be available for greater pulling loads than indicated in the tabulated values. Contact AMERICAN when higher pulling loads are required.

^ Approximate radius of curve produced by a succession of 20' lengths of pipe fully deflected.

^^ Based on weight of empty (full of air) Pressure Class 350 Flex-Ring pipe with standard cement lining immersed in water. Positive numbers indicate such pipe will float.

Table No. 7-14

14"-48"

Size in.	Working Pressure* psi	Nominal Laying Length** ft.	A O.D. in.	B Socket Depth in.	F Bell O.D.† in.	Allowable Pulling Load lb.††	Allowable Deflection degree	Offset per 20' Length in.	Radius of Curve^ ft.	Empty Pipe Buoyancy in Water (lb/ft)^^^
14	350	20	15.30	7.38	19.31	75,000	4	17	285	27
16	350	20	17.40	7.38	21.08	95,000	3 3/4	16	305	38
18	350	20	19.50	8.20	23.70	120,000	3 3/4	16	305	52
20	350	20	21.60	8.20	25.37	150,000	3 1/2	15	327	69
24	350	20	25.80	8.96	29.88	210,000	3	12	380	104
30	250	20	32.00	9.63	36.34	220,000	2 1/2	10	458	175
36	250	20	38.30	9.63	43.10	310,000	2	8	570	266
42	250	20	44.50	10.84	49.92	390,000	2	8	570	359
48	250	20	50.80	12.37	56.36	500,000	2	8	570	484
54	250	20	57.56	12.74	63.90	650,000	1 1/2	8	570	632

* Working pressure is the maximum pressure rating of the joint and is based on its capability to resist thrust due to internal pressure. If higher working pressure is required, contact AMERICAN. Pressure rating of the joint is limited by the pressure rating of the parent pipe.

** Laying length is nominal 20'. Where exact lengths are required, contact AMERICAN.

† Dimensions subject to change at our option. Contact AMERICAN if smaller or exact dimensions are required.

†† Intended for horizontal directional drilling (HDD) applications. The tabulated values are based on Pressure Class pipe thickness of the "Working Pressure" shown. Contact AMERICAN when it may be desirable to use lesser pressure class pipe or when higher pulling loads are required. Flex-Ring pipe may be available for greater pulling loads than indicated in the tabulated values.

^ Approximate radius of curve produced by a succession of 20' lengths of pipe fully deflected.

^^ Based on weight of empty (full of air) Pressure Class 350 Flex-Ring pipe with standard cement lining immersed in water. Positive numbers indicate such pipe will float.

Minimum Laying Lengths

Size in.	Flex-Ring & Flex-Ring End	Flex-Ring End & Flex-Ring End
14	1'-6"	2'-0"
16	1'-6"	2'-0"
18	1'-6"	2'-0"
20	1'-6"	2'-0"
24	2'-0"	2'-6"
30	2'-0"	2'-6"
36	2'-0"	2'-6"
42	2'-0"	3'-0"
48	2'-6"	3'-0"
54	3'-0"	3'-6"



AMERICAN DUCTILE IRON PIPE

AMERICAN Ductile Iron Specials
AMERICAN Fastite Joint Push-Bar Pipe

ANSI/AWWA C151/A21.51 and AMERICAN Standard

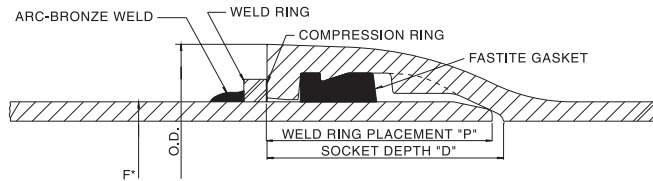
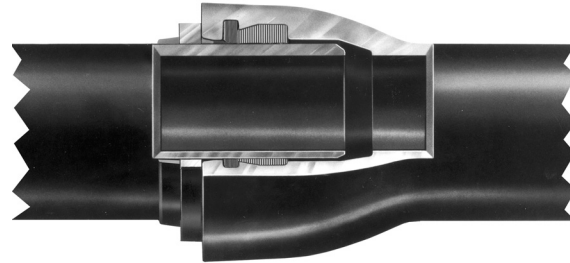

Table No. 7-15

Pipe Size in.	Standard Nominal Laying Length	Pipe O.D. in.	F* Bell O.D. in.	Weld Ring Size	P in.	D in.	Rated Push** (lb. x 1000)
4	20	4.80	6.40	1/2" sq.	3.13	3.31	54
6	20	6.90	8.60	1/2" sq.	3.25	3.38	78
8	20	9.05	10.96	1/2" sq.	3.63	3.75	102
10	20	11.10	13.12	1/2" sq.	3.63	3.75	125
12	20	13.20	15.22	1/2" sq.	3.63	3.75	150
14	20	15.30	17.61	1/2" sq.	5.00	5.23	260
16	20	17.40	19.74	1/2" sq.	5.00	5.23	296
18	20	19.50	22.16	1/2" sq.	5.38	5.50	312
20	20	21.60	24.28	1/2" sq.	5.38	5.50	345
24	20	25.80	28.50	1/2" sq.	5.38	5.50	413
30	20	32.00	34.95	5/8" sq.	6.38	6.50	545
36	20	38.30	41.37	5/8" sq.	6.38	6.50	650
42	20	44.50	48.27	3/4" x 1 1/4" rect.	7.38	7.50	818
48	20	50.80	54.71	3/4" x 1 1/4" rect.	7.88	8.00	934
54	20	57.56	61.65	3/4" x 1 1/4" rect.	8.38	8.50	1,058
60	20	61.61	65.80	3/4" x 1 1/4" rect.	8.62	8.75	1,132
64	20	65.67	70.04	3/4" x 1 1/4" rect.	8.88	9.00	1,206

* Dimensions subject to change at our option. Contact AMERICAN if exact dimensions required.

**Allowable axial compression loads for the Fastite push-bar joint in straight alignment. Contact AMERICAN if higher pushing loads are required.

See Section 3 for pipe classes and pressure ratings



Long-Span and Piping Supports

The beam strength of ductile iron pipe, along with the capability of certain AMERICAN joints, allows the installation of clear spans of up to 48' or more in sizes 6" * - 64". This was made possible due to the advent of AMERICAN's unique Toruseal® gaskets** in the 1970s.

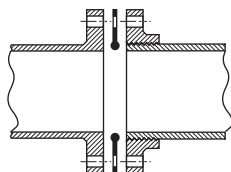

Shown below are sketches of three cases of long-span or pipe-on-supports situations. Case #1 shows traditional pipe-on-supports installations where one support is provided for each length of pipe. Cases #2 and #3 show long-span pipe assemblies that use AMERICAN's Toruseal® gaskets. Other pipe assemblies using other AMERICAN joints may be possible depending upon circumstances. Notes under each case apply to that case. General notes are shown at the end.

*Contact AMERICAN on long-span requirements involving 4" pipe.

**See Sections 6 and 8 for details on Toruseal Gaskets.

Case #1

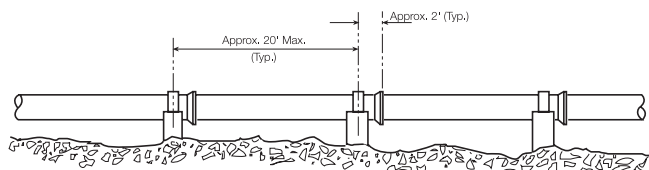

Case #1 uses 20' or less lengths of Fastite, MJ, or other push-on restrained pipe. (See page 7-29 General Note 3.) This length is normally subject to normal manufacturing and trim (cut pipe) variations, with some pipe allowed up to two feet shorter than full length. Where exact length pipe is required, say to fit existing pier spacings, etc., contact AMERICAN.

Minimum pressure classes of all sizes of ductile iron pipe are more than adequate to support the weight of the pipe and the water it contains in Case #1 installations when analyzed and installed in accordance with the suggestions in the Ductile Iron Pipe Research Association's procedure for "Design for Ductile Iron Pipe on Supports." This procedure is available from AMERICAN.



Long-Span and Piping Supports

Case #2

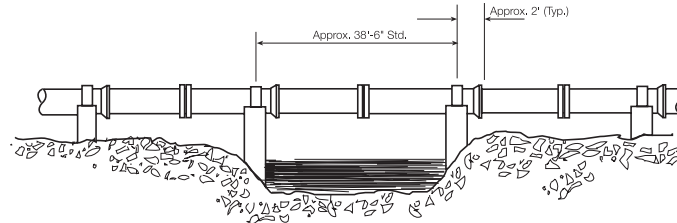

Case #2 uses 19'-3" lengths of flange plain end and flange bell (Fastite, MJ, or other push-on restrained) pipe. (MJ pipe is not available over 12" in diameter.) Since Case #2 uses flanged pipe joints, minimum nominal thicknesses shown in AWWA C115 are required.

Case #3

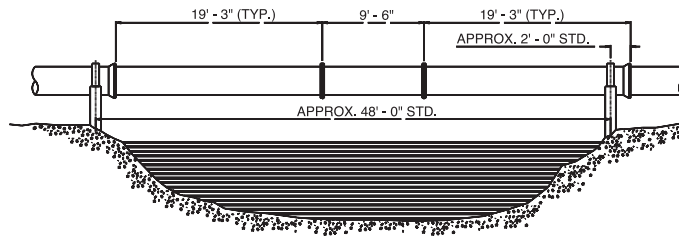

Case #3 uses 19'-3" lengths of flange bell and flange plain end pipe with a 9'-6" flange-flange pipe in the center. This can result in more mid-span deflection than Case #2 and, therefore, it is normally used only in 18" and larger sizes.

Since Case #3 uses flanged pipe joints, minimum nominal thicknesses for fabricated flanged pipe shown in AWWA C115 are required.



LONG SPAN AND PIPING SUPPORTS

GENERAL NOTES

1. Principles presented in the DIPRA publication "Design of Ductile Iron Pipe on Supports" can be used to calculate the maximum localized stress due to support reaction and to approximate the maximum beam-bending stress near mid-span of these systems. This publication can be obtained from AMERICAN.

2. Small-diameter pipe systems with very long unsupported pipe spans can exhibit visible mid-span deflection, or "sag." While this deflection results in no structural problems, the designer may consider means to reduce or eliminate midspan deflection if aesthetic or other concerns are anticipated in the application.

3. Push-on or push-on restrained joint pipe is normally a better choice than mechanical joint pipe due to more tolerance for thermal expansion and contraction, movement effects, and other aspects. Mechanical joints are not available from AMERICAN for ductile iron pipe over 12".

4. Where pipeline bends adjacent to crossings are externally restrained for restraint of axial pressure thrust, or where there are no bends adjacent to crossings to result in such thrusts, it is common to install push-on or mechanical pipe joints with a slight axial "gap" (1/8"-1/4") between the spigot and the back of the socket, and with the pipe sections firmly strapped to shaped pier supports located immediately behind the pipe bells as indicated. This is appropriate for normal anticipated thermal expansion and contraction of individual pipe sections and is easy to accomplish in the field by assembling the joints to metal contact condition and then "backing them out" slightly. Slight rebating deflection (or "wiggling") of the joint can produce the desired results, with field marking of the relative position of the spigot to the bell face to gauge results.

5. It is generally recommended that effective lateral restraint (means of assuring lateral stability of joints) be provided for the joints of all pipe-on-support installations, particularly in pressure pipelines and in other cases where lateral or columnar forces may exist to deflect joints or to dislodge the pipeline from the supports. Unstabilized, single rod or other hangers may not be desirable for pressure or other pipelines.

6. Contact AMERICAN where other design factors are a consideration. Systems where crossing pipe is subject to axial thrust forces or movements from bends, etc., long bridge crossings, large or concentrated thermal expansion-contraction effects, pipe-on-rollers, etc., are applications that may involve special design concerns.

7. The piping layouts as per Cases 2-3 consider the possibility of projects with sizable numbers of exact length repetitive pipe "spans." Where lesser numbers of spans are involved on candidate projects, it may be practical and more economical to provide slightly longer "standard spans," say by furnishing longer laying length intermediate flanged pipe (see Sec. 8) in lieu of the 19'-3" lengths depicted in these cases, etc. Contact AMERICAN if this is necessary or desirable.