

## Blackmagic Studio Camera 6K Pro



**\$2,495**

Designed as the ultimate studio camera, Blackmagic Studio Camera 6K Pro adds a larger 6K Super 35 sensor and EF lens mount for true cinematic images in live production. There are built in ND filters that let you reduce the amount of light entering the camera, allowing you to work in a wider range of situations, including in bright sunlight. Plus stream direct to the internet with built in streaming! You also get 12G-SDI, HDMI and 10G Ethernet which allows all connections on a single cable for a SMPTE style workflow that's much lower cost.

### Camera Features

#### Effective Sensor Size

23.10mm x 12.99mm (Super 35)

#### Lens Mount

Active EF mount.

#### Lens Control

Iris, focus, zoom on supported lenses.

#### Dynamic Range

13 Stops.

#### Dual Native ISO

0dB and 18dB gain.

#### Sensitivity at 0dB Gain

f11 with 2160p59.94.

f12 with 2160p50.

at 2,000 lux with 89.9% reflectance.

#### Signal to Noise Ratio

64.62dB for 2160p

Ultra HD scaled from 5.3K

#### Recording Resolutions

6144 x 3456 (6K) up to 50 fps

6144 x 2560 (6K 2.4:1) up to 60 fps

5376 x 3024 (5.3K 16:9) up to 60 fps

3840 x 2160 (Ultra HD) up to 60 fps

#### Video Output Standards

2160p, 1080p, 1080i

#### Frame Rates

Project frame rates of 23.98, 24, 25,

29.97, 30, 50, 59.94 and

60 fps supported.

Off-speed frame rates 5 - 50 fps in 6K,

and 5 - 60 fps for all other

recording resolutions.

#### Built in ND Filters

Four position ND filter with clear,

2-stop, 4-stop and 6-stop IR

ND filters.

#### Focus

Auto focus available using compatible lenses.

#### Screen Dimensions

7 inch 1920 x 1200

#### Screen Type

LCD capacitive touchscreen.

#### Screen Brightness

2000 nits

#### Controls

Touchscreen camera settings and menus with rotary settings dial, program button, F1, F2 and F3 assignable function buttons, brightness contrast and peaking dials.

#### Mounting Options

2 x 1/4 inch tripod mount.

1 x 3/8 inch tripod mount.

---

## Connections

### **SDI Video Inputs**

1

### **SDI Video Outputs**

1

### **SDI Rates**

1.5G, 3G, 6G, 12G.

### **HDMI 2.0 Video Outputs**

1

### **Analog Audio Input**

2 x XLR analog switchable between mic and line levels. Phantom power support.

1 x 3.5mm Stereo Input. Can also be used for Timecode input.

### **Analog Audio Output**

1 x 5-pin XLR for talkback headset.

1 x 3.5mm TRRS mini jack for headphones with mic.

### **SDI Audio Output**

2 channels of program audio embedded in 1.5G/3G/6G/12G-SDI.  
2 talkback channels on 15 and 16.

### **Reference Inputs**

Tri-Sync or Black Burst when used with optional Blackmagic Studio Converter.

### **Remote Control**

Remote camera control over SDI, HDMI or Ethernet.

### **Ethernet**

10Gb/s

### **Computer Interface**

2 x USB Type-C 3.1 Gen 1 (up to 5Gb/s) expansion ports for external recording and focus / zoom demand connection. Software updates using USB-C Port A.

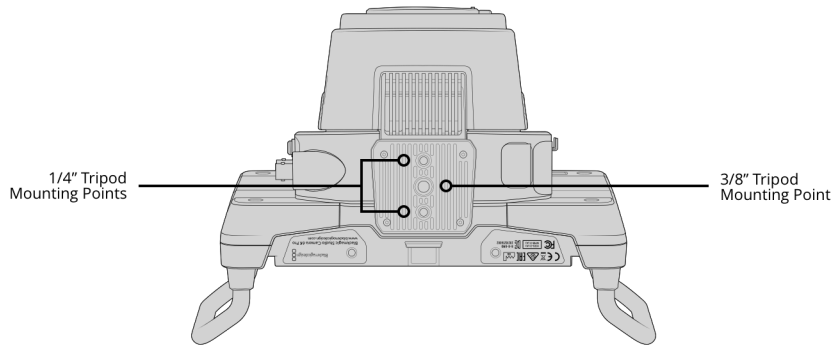
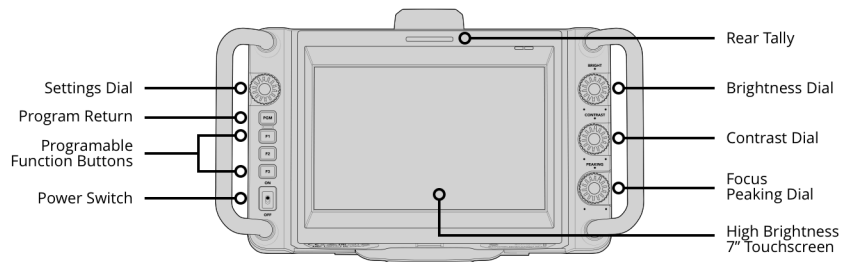
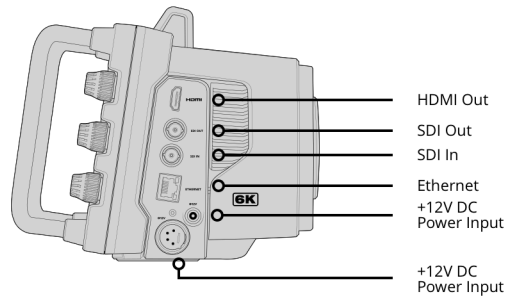
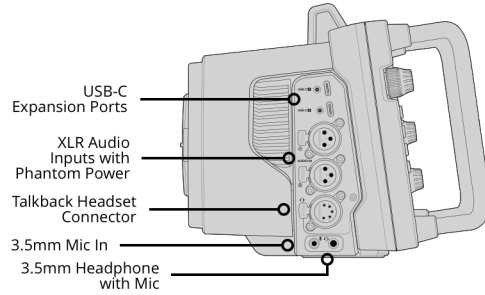
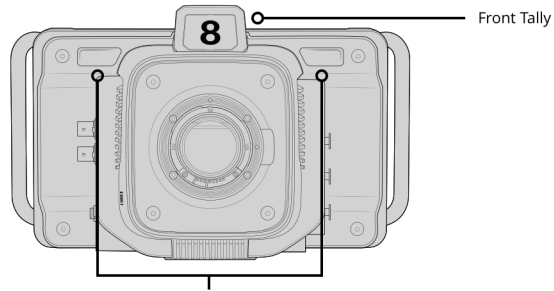

---

## Audio

### Microphone

Integrated stereo microphone.

### Built in Speaker

1 x mono speaker.

---

## Streaming

### Direct Streaming

Blackmagic Studio Camera 6K Pro supports direct live streaming using Real Time Messaging Protocol (RTMP) over ethernet or a shared mobile internet connection over USB-C.

### Streaming Platforms

ATEM Television Studio HD8 ISO, ATEM Streaming Bridge, Facebook, Twitch, YouTube, Twitter, Restream.IO, Vimeo, BoxCast, Castr, Afreeca TV, Bilibili, DouYu, Weibo.

---

## Standards

### SD Video Standards

None

### HD Video Standards

1080p23.98, 1080p24, 1080p25, 1080p29.97, 1080p30, 1080p50, 1080p59.94, 1080p60, 1080i50, 1080i59.94, 1080i60

### Ultra HD Video Standards

2160p23.98, 2160p24, 2160p25, 2160p29.97, 2160p30, 2160p50, 2160p59.94, 2160p60

### SDI Compliance

SMPTE 292M, SMPTE 424M, SMPTE 425M level A and B, SMPTE 2081-1, SMPTE 2081-10, SMPTE 2082-1 and SMPTE 2082-10

### SDI Audio Sampling

Television standard sample rate of 48 kHz and 24-bit.

---

## Media

### Media

2 x USB-C 3.1 Gen 1 expansion ports for external media for recording Blackmagic RAW.

### Media Format

Can format media to ExFAT (Windows/Mac) or HFS+ (Mac) file systems.

---

## Supported Codecs

### Codecs

Blackmagic RAW Constant Bitrate 3:1  
Blackmagic RAW Constant Bitrate 5:1  
Blackmagic RAW Constant Bitrate 8:1  
Blackmagic RAW Constant Bitrate 12:1  
Blackmagic RAW Constant Quality Q0  
Blackmagic RAW Constant Quality Q1  
Blackmagic RAW Constant Quality Q3  
Blackmagic RAW Constant Quality Q5

---

---

## Storage Features

### Storage Type

2 x USB-C 3.1 Gen 1 expansion ports for external media.

### Recording Formats

Blackmagic RAW 3:1, 5:1, 8:1, 12:1, Q0, Q1, Q3 and Q5 in 6K (6144 x 3456), 6K 2.4:1 (6144 x 2560), 5.3K 16:9 (5376 x 3024), Ultra HD (3840 x 2160) at the selected frame rate.

### Storage Rates

Storage rates based on 30 frames per second.

#### 6144 x 3456 (6K)

Blackmagic RAW 3:1 - 323 MB/s

Blackmagic RAW 5:1 - 194 MB/s

Blackmagic RAW 8:1 - 121 MB/s

Blackmagic RAW 12:1 - 81 MB/s

Blackmagic RAW Q0 - 242 to 483 MB/s

Blackmagic RAW Q1 - 162 to 387 MB/s

Blackmagic RAW Q3 - 108 to 277 MB/s

Blackmagic RAW Q5 - 65 to 162 MB/s

#### 6144 x 2560 (6K 2.4:1)

Blackmagic RAW 3:1 - 240 MB/s

Blackmagic RAW 5:1 - 144 MB/s

Blackmagic RAW 8:1 - 90 MB/s

Blackmagic RAW 12:1 - 60 MB/s

Blackmagic RAW Q0 - 180 to 359 MB/s

Blackmagic RAW Q1 - 120 to 287 MB/s

Blackmagic RAW Q3 - 80 to 205 MB/s

Blackmagic RAW Q5 - 49 to 120 MB/s

#### 5376 x 3024 (5.3K 16:9)

Blackmagic RAW 3:1 - 248 MB/s

Blackmagic RAW 5:1 - 149 MB/s

Blackmagic RAW 8:1 - 94 MB/s

Blackmagic RAW 12:1 - 63 MB/s

Blackmagic RAW Q0 - 186 to 371 MB/s

Blackmagic RAW Q1 - 125 to 297 MB/s

Blackmagic RAW Q3 - 84 to 212 MB/s

Blackmagic RAW Q5 - 50 to 125 MB/s

#### 3840 x 2160 (Ultra HD)

Blackmagic RAW 3:1 - 127 MB/s

Blackmagic RAW 5:1 - 77 MB/s

Blackmagic RAW 8:1 - 48 MB/s

Blackmagic RAW 12:1 - 32 MB/s

Blackmagic RAW Q0 - 96 to 190 MB/s

Blackmagic RAW Q1 - 64 to 153 MB/s

Blackmagic RAW Q3 - 43 to 109 MB/s

Blackmagic RAW Q5 - 26 to 64 MB/s

Constant Quality storage rates quoted are indicative only.

Actual storage rates are entirely dependent on image subject matter.

---

## Control

### External Control

Blackmagic Zoom Demand and Blackmagic Focus Demand for controlling your camera and lens from tripod handles.

Blackmagic Control Protocol over SDI, RTMP and HDMI for external control when used with a compatible ATEM switcher with ATEM Software Control or ATEM Camera Control Panel. Includes control of some camera settings, focus, iris and zoom with compatible lenses, color corrector, tally and record start and stop to external media via USB expansion port.

Camera Control REST API over Ethernet or USB Ethernet for external control via HTTP when used with REST client applications such as Postman.

---

## Network Management

### NTP

Network time protocol support allows you to sync the time on your camera, whenever connected to a network with any NTP server of your choice.

### Web Media Manager

Using a browser connected over Ethernet, web media manager allows you to access, browse, download and delete files from any drive connected to the camera.

### FTP

Download files from any drive attached to your camera using FTP.

### SMB

File sharing using SMB

---

## Color Corrector

DaVinci YRGB

---

## Talkback and Tally

### Live Tally Indicator

1 x front facing for talent,  
1 x rear facing for operator.

### Talkback

SDI Channels 15 and 16.

---

## Software

### Software Included

Blackmagic Camera Setup for Mac and Windows.

---

---

## Operating Systems



Mac 12.0 Monterey,  
Mac 13.0 Ventura or later.



Windows 10, 64-bit.  
Windows 11.

---

## Power Requirements

### Power Supply

1 x External 12V DC 60W power supply.

### Power Inputs

1 x 12V DC locking 5.5 mm barrel connector.

1 x 12V DC 4 pin XLR input for external power supply or battery use.

1 x RJ45 Ethernet connector for power from Type 4 PoE power supplies.

### Power Usage

32 - 52 W using DC input.

38 - 59 W using Type 4 PoE input.

---

## Optional Accessories

Blackmagic Focus Demand

Blackmagic Zoom Demand

Blackmagic Studio Converter

ATEM Mini switchers

ATEM SDI switchers

ATEM Constellation switchers

ATEM Television Studio switchers

ATEM Streaming Bridge

Blackmagic MultiDock 10G

HyperDeck Studio HD Plus

HyperDeck Studio 4K Pro

SmartView 4K

Blackmagic Cloud Pod

Blackmagic Cloud Store

Blackmagic Cloud Store Mini 8TB

Ultimatte 12 HD Mini

Ultimatte 12 HD

Ultimatte 12 4K

Blackmagic 3G-SDI Shield for Arduino

---

## Physical Specifications



---

## Environmental Specifications

### Operating Temperature

0° to 40° C (32° to 104° F)

### Storage Temperature

-20° to 45° C (-4° to 113° F)

### Relative Humidity

0% to 90% non-condensing

---

## What's Included

- Blackmagic Studio Camera 6K Pro
- Blackmagic Studio Camera Sun Shade
- Tripod Mount compatible with 15mm lightweight rails
- Tripod Mount Plate
- Turret Dust Cap
- External 12V DC power supply with locking connector and international sockets adapters for most countries.
- Welcome wallet with QR code for software download
- DaVinci Resolve download card
- Blackmagic Design sticker



---

## Warranty

12 Month Limited Manufacturer's Warranty.

All items on this website are copyright Blackmagic Design Pty. Ltd. 2023, all rights reserved. All trademarks are property of their respective owners. MSRP includes duties, but excludes sales tax and shipping costs. This website uses remarketing services to advertise on third party websites to previous visitors to our site. You can opt out at any time by changing cookie settings. [Privacy Policy](#)

Blackmagic Design Authorized Reseller