



Experience Innovation

## Model: 8" Compressor-Assisted Solids Handling Pump

Name: 8JSCE

With its heavy-duty cast-iron construction and fast priming capabilities, the Thompson 8JSCE solids handling end suction centrifugal pump leads the industry in construction, industrial and municipal applications. The Thompson 8JSCE is designed for moderate flows up to 3,200 gpm and heads up to 273 feet making it perfect for sewage bypass pumping or general construction dewatering.



Photo shown may not be exact model.  
Consult factory for other options.

Pump End Materials	
<b>Pump Casing</b>	Heavy-duty class 30 ductile iron.
<b>Impeller</b>	Dynamically balanced, non-clogging, enclosed, 65-45-12 ductile iron with rear-equalizing vanes to reduce axial loading and prolong seal and bearing life; diameter 14".
<b>Mechanical Seal</b>	Dry-running, grease or oil lubricated with tungsten carbide rotating and silicon carbide stationary seal faces. Single inside mounted, non-pusher type with self-adjusting elastomeric bellows. Other components are 304 stainless steel and Viton.
<b>Head</b>	Rugged, back pull out design, heavy-duty class 30 cast iron with tapered bore design.
<b>Bearings</b>	Heavy-duty grease lubricated to carry both axial and radial loads.
<b>Bearing Frame</b>	Heavy-duty class 30 ductile iron.
<b>Shaft</b>	SAE1144 high quality steel with renewable 416 stainless shaft sleeve.

Technical Specifications			
Suction Size	8 in (20.32 cm)	Approximate Dry Weight	5,475 lbs (2,483.42 kg)
Discharge Size	8 in (20.32 cm)	Best Efficiency	80%
Maximum Solids Handling	3 in (7.62 cm)	Maximum Operating Speed	2,000 rpm
Maximum Operating Temperature	200° F (93.33° C)	Maximum Operating Pressure	118.18 psi (814.83 kPa)

Fuel Tank Options*		John Deere
Modular (M)	114 Gal	23 Hours

\*Contact factory for fuel tank sizes not listed above.

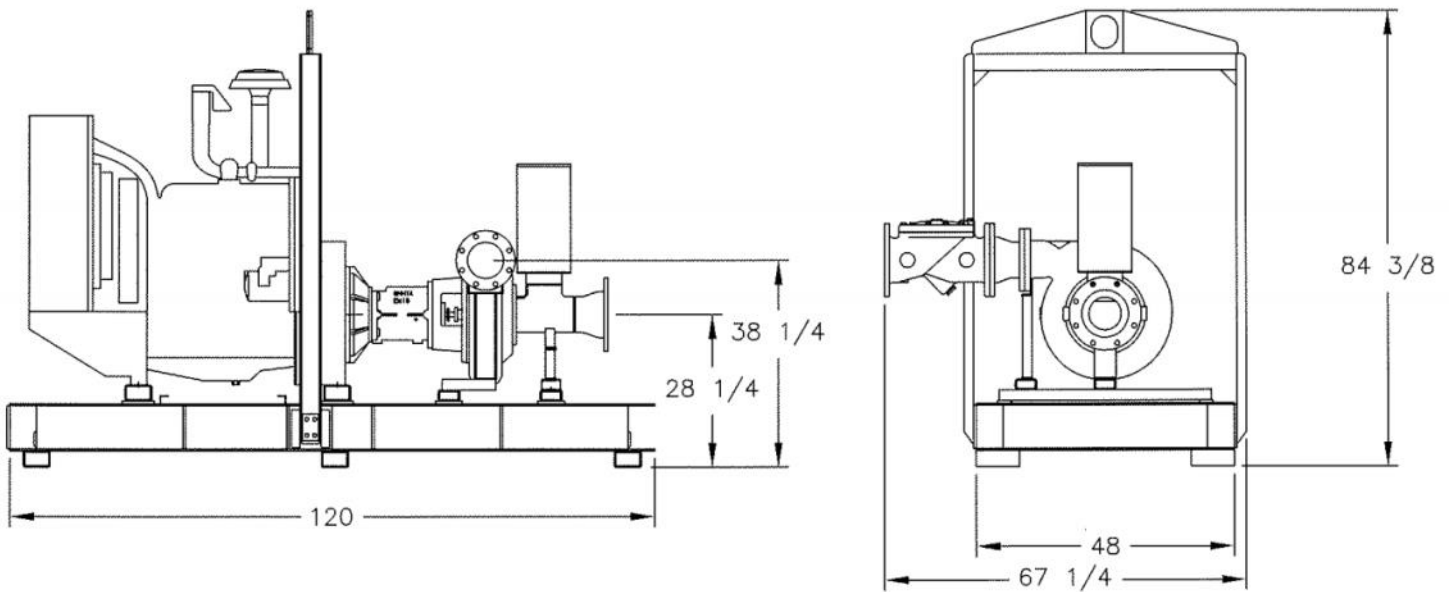
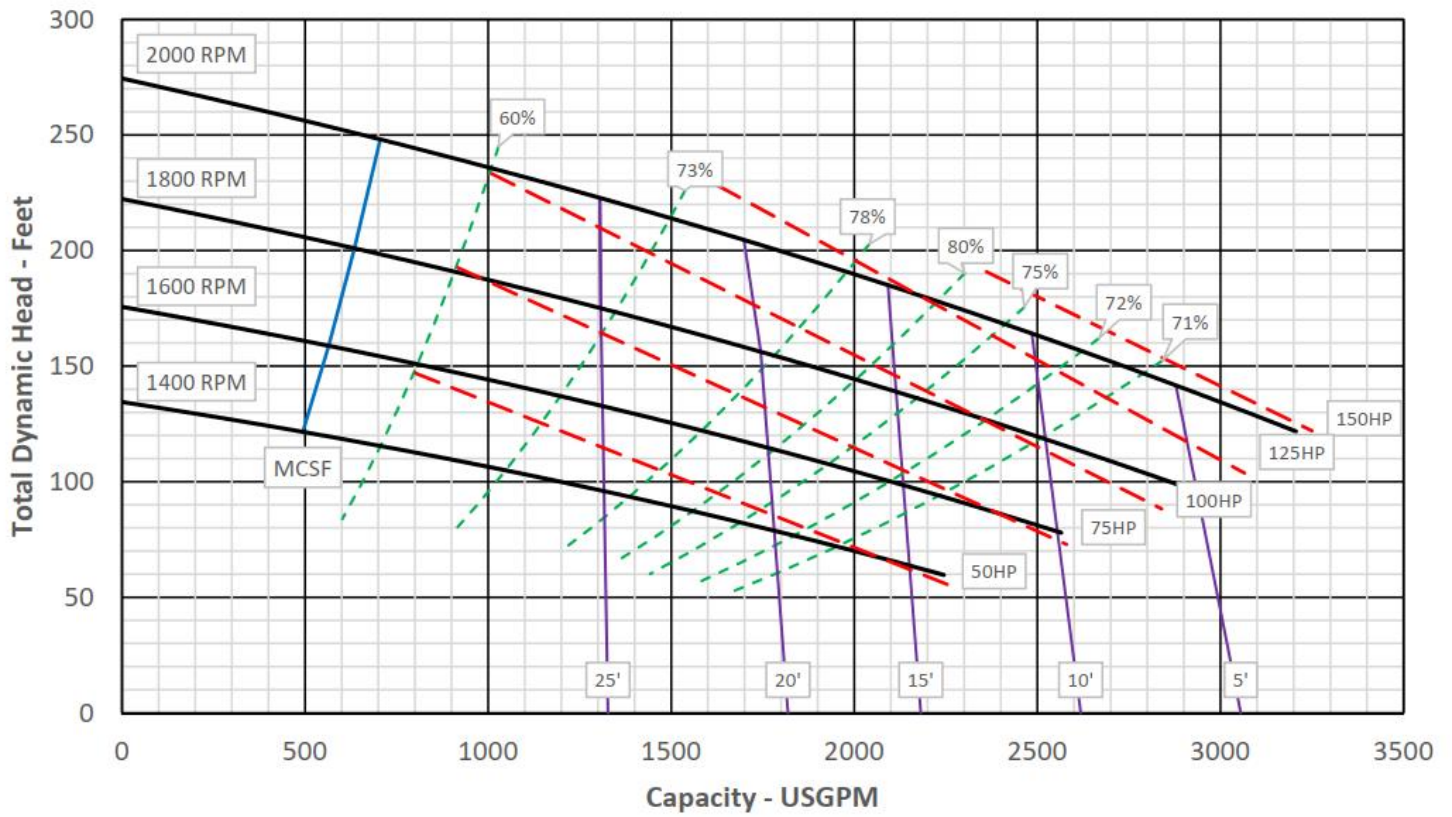

### John Deere 6068HF285 — 156 hp @ 2,400 rpm

Typical Operating Speed	2,000 rpm	Engine Speed	Fuel Economy	Run
Maximum Head	273 ft (83.21 m)	2,000 rpm	0.378 lb/hp-hr	13 hrs
Maximum Flow Capacity	3,200 gpm (726 m <sup>3</sup> /hr)	1,800 rpm	0.375 lb/hp-hr	17 hrs
Maximum Fuel Consumption	8.41 gph (31.84 L/hr)	1,600 rpm	0.374 lb-hp-hr	23 hrs

\*Engine run times calculated based on a 114 gallon fuel tank.

Specifications and illustrations are subject to revision without notice and without incurring any obligation for previous or subsequent equipment sold. Thompson Pump (ISO 9001:2015) makes no representation regarding the completeness or accuracy of this information and is not liable for any direct or indirect damages arising from or relating to this information or its use. Capacity & Head are shown for comparative purposes. Consult Thompson factory for exact capabilities.