

Industrial Measuring Devices

A Passion for Precision

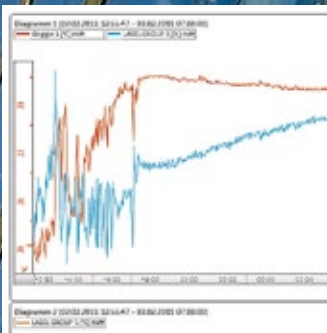

por la precisión · passione per la precisione · a passion for precision · passion pour la précision · pasión por



www.lufft.com

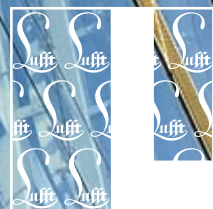

Lufft

Measure and record
data easily and
precisely.

Quality made in
Germany without
compromises.

Precision in the

Palm of your Hand

The highly demanding and complex measuring tasks of today can only be mastered with high-precision devices. The special requirements placed on hand-held measuring devices are the result of the spectrum of physical measurements that are to be measured, as well as the decisions that are based on this measured data. Architects, specialists and surveyors, engineers, climate experts and many other professionals bear the responsibility for people, technology, goods and processes. Whether you are investigating or recording the temperature of a surface without contact, the dew point temperature of air on walls, the moisture content of oil, air pressure or air flow, Lufft hand-held devices are easy to operate and – above all – precise!

The **XA1000 hand-held-measuring device** is an all-round device that fulfils the highest demands. Various high-precision climatic measuring technology sensors can be alternatively connected. The measurement results are displayed in high resolution colour displays both in graphic and numeric formats. The integrated data recorder allows the measurement results to be transferred to a computer; for this purpose the Lufft software SmartGraph3 is ready and waiting.

The **XP Series** consists of hand-held measuring devices for specialists. The highest temperature precision combined with the most modern handling of measured data. This also applies to airflow, temperature and relative humidity, as well as CO2. The ideal hand-held measuring device for any measuring task.

The **XC Series** rounds off the diverse range of hand-held measuring devices. A special option is the combination of temperature/relative humidity with (infrared) surface temperature in order to identify areas affected by dampness e.g. in the walls of buildings.

The **OPUS20 Dataloggers** are the stationary equivalent of the X-Series hand-held measuring devices. Many of the sensors offered can be used with both X-Series and OPUS20 Dataloggers. The devices are available with built-in sensors as well as with external sensors (intelligent) that can be connected. The OPUS20 are LAN capable and are configured and analyzed using SmartGraph3.

Functionality and Product Specs
With the **Lufft I-Box**, measurement instruments such as the data logger OPUS20 can easily be integrated into corporate networks. The “plug-and-play” solution gives a uniform query to live data from different instruments. Thus, all data can be clearly displayed. In addition, an application for controlling alarms is included. The applications can be extended to suit individual needs.

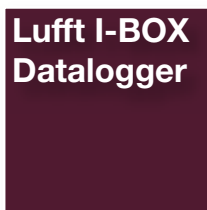
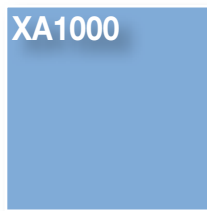

The Software

SmartGraph3 manages and files measured data from both hand-held measuring devices and dataloggers. The managing of data can be carried out in real time (LAN datalogger) or also in cyclical readouts of the monitoring network. The configuration section of SmartGraph3 allows the measuring components to be setup for their respective applications. If the scope of operation of SmartGraph is not adequate for a special application, then we offer the optional **Software MCPS7** which fulfils all customer requirements up to and including customer-specific solutions.



Brand of the Century

As the only measurement technology company in its segment, Lufft was presented with this special award in 2012 as recognition for its uncompromising quality within the temperature measurement technology during its 100

year company history.

Calibration rounds off the quality requirements. Measuring devices without a measuring log lack traceability. The reference measurement in conjunction with reference norms ensures that your measuring device remains your reliable supplier of measured data throughout its entire period of use. Lufft is DKD-Labor certified for temperature, relative humidity, air pressure and airflow.



**As tasks increase
so do requirements.**

*Lufft's sophisticated
measuring technology
is more than a match for
today's high demands.*

Functions and

Measurement Categories



Lufft's hand-held measuring device product range is comprehensive and can be implemented in a full spectrum of various application areas. By using the table below you will be able to get an overview of the most important device features. This will enable you to find the right device from the various series that best meets your needs. Take your time and compare the range of functions offered with those of competitors' products and you will discover that Lufft is in a class of its own.

The physical measurements offered are the most important factor when selecting a hand held device for various applications. For this purpose we have compiled a concise table to be used as a general overview. More detailed information regarding our measuring devices and connectable sensors can be found in the technical descriptions on the following pages.

Functions							
Functions and Features of Lufft Measuring Devices							
Functions and Features	XA1000	XP100	XP101	XP200	XP400	XC200	XC250
Colour TFT-LCD (QVGA)	■	■	■	■	■		
Colour display						■	■
Legible in sunlight	■	■	■	■	■		
Illumination dimmable	■	■	■	■	■		
Touch operation	■	■	■	■	■		
SmartGraph3 support (USB)	■	■	■	■	■		
Firmware update possible online	■	■	■	■	■		
Firmware update possible offline						■	■
Interface for SDI and digital sensors	■	■	■	■	■		
Data storage (200 data files/1Mio measured values)	■	■	■	■	■		
Low power design (>24h@4xAA)	■	■	■	■	■		
Intuitive operation	■	■	■	■	■		
Graphical user interface	■	■	■	■	■		
Big figures						■	■
Integrated sensors						■	■

Measurement Categories								
What you can measure with Lufft measuring devices - now and in the future.								
Measurement Categories		XA1000	XP100	XP101	XP200	XP400	XC200	XC250
Temperature (C° /°F)	Air temperature	■	■	■	■	■	■	■
	Surface temperature		■	■				
	Infrared temperature (non-contact)							■
	Dew point temperature of the air	■			■		■	■
	Dew point temperature on walls							■
Humidity % RH	Air humidity	■			■		■	■
	Absolute humidity	■			■		■	■
Airflow (m ³ /s)	Airflow	■				■		
Pressure (hPa)	Absolute pressure	■			■	■		
	Air pressure	■			■	■		
CO ₂	CO ₂ concentration (ppm)	■			■			

The multi-talented device on the measuring technology scene.

One device instead of several – universal and flexible thanks to its digital sensor interface.

X(per) A(dvanced)

XAT1000

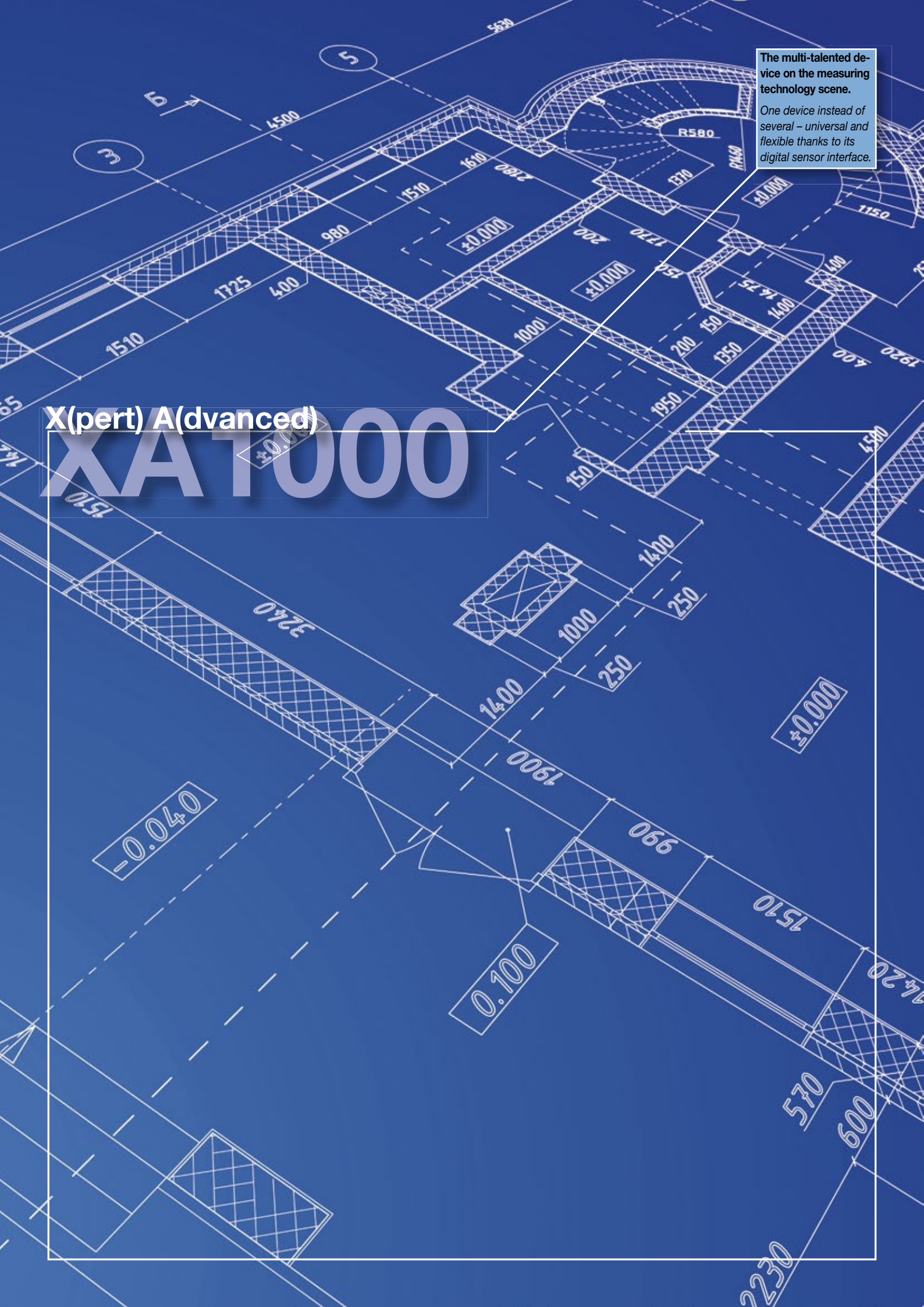



A complete package: the XA1000 is specially engineered for the requirements in the areas of heating/air conditioning and ventilation to measure temperature, humidity and air flow.

Without a doubt the XA Series represents the advanced technology in Lufft's measuring device product range – a specially advanced device generation that utilises luminous colour displays and works with intelligent sensors. With the help of SmartGraph3, the recorded data taken from your measuring campaigns can be archived and analysed clearly.

The Smartphone for measurement technology – this was the requirement for the product development of the XA1000.

The ergonomic-optimised hand-held measuring device automatically recognises each connected sensor. The colour display reacts to your touch; alternatively the control pad below the display can be used to control the functions. In addition to the high-resolution representation of the measured values, the measuring curves can also be analysed in chronological sequence on the display.

As a special feature, the XA1000 comes with all possible calculations that can be determined with the help of the measured physical measurements: Dew point, wet-bulb temperature, absolute humidity, enthalpy and much more.

The Windows compatible SmartGraph3 software is included in delivery and in addition provides a clear representation and simple compilation of all measured data. This full-featured software can display measured values in both tables and graphs and possesses standard functions such as print and export, as well as zoom and scroll tools for specific, graphical analysis.

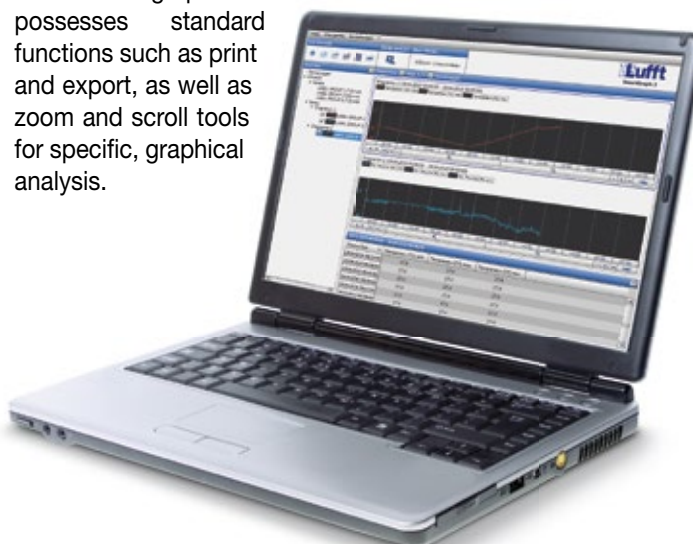

Robust technology
in a sophisticated
design.

*Precision and reliability
in one – made by
professionals for
professionals*

Measuring on the Go



- TFT colour display, legible in sunlight
- Capacitive touch operation
- Sampling rate 1s
- Data recording of up to 3 channels in parallel
- Graphical analysis with standard deviation resolution
- Integrated Flash memory for 200 recording blocks with maximum length of 3 hours
- USB port for data transfer to SmartGraph3 (included in delivery)
- Various languages selectable
- Measuring temperature, humidity, airflow via external digital sensors
- Integrated air pressure measurement
- Numerous calculated measurements
- Online firmware update

Premium Segment XA1000



The most precise and flexible all-rounder instrument for professional applications—easy to handle and robust. Allows various intelligent sensors to be connected with automatic recognition, saves measuring campaigns, allows all climate data to be calculated and archived on a computer for further evaluation by SmartGraph3 software.

Hand-held Measuring Device XA1000 "All-in-ONE"		Order No.
"All-rounder" in the measurement technology segment. A universal measuring device for professionals with the inclusion of exchangeable SDI Sensors. Highly precise measurements of temperature and relative humidity. Integrated air pressure sensor, online/offline data recording. Equipment test certificate, can be calibrated.		5900.00
Technical data	Dimensions	170x62x34mm
	Weight	ca. 205g
Storage conditions	Permitted ambient temperature	-20...60°C
	Permitted rel. humidity	<90% RH non-condensing
Operating conditions	Permitted rel. humidity	<90% RH (20g/m³) non-condensing
	Permitted altitude above sea level	4000m
Power supply	Power supply	4 Alkaline LR6 AA 1.5V / USB 5V
	Active power consumption	Approx. 400mW
	Battery life passive	Approx. 1 year
	Battery life active	Min. 24 hours
	Sensor power supply	5.5V ± 10% DC, max. 200mA
Data storage	Integrated data storage	Up to 200 gauges taking approx. 1 mill. values
Interface	USB	Cable and SmartGraph3 software included
Resolution	Definition of measured values	2 decimal places
Display	Control	Touch screen, capacitive
	Technology	TFT, resolution 240x320, 65k colours, very good contrast due to Piezoresistive technology
	Surface, toughened glass	Degree of hardness: 7, scratch-resistant
Integrated air pressure sensor	Measuring range (full accuracy)	800...1,100mbar
	Accuracy at 25°C, 1013.25mbar	0.5mbar
	Long-term stability	typ. - 1mbar/year
	Measurement resolution	0.024mbar
	Measuring principle	Piezoresistive
Calculated measurement categories for external temperature/humidity sensors	Mathematical: MIN/MAX/AVG/HOLD	
	Temperature (°C/°F)	
	Rel. humidity (% RH)	
	Rel. humidity of ice (% RH)	
	Water vapour density (absolute humidity) g/m³	
	Dew point temperature °C/°F	
	Frost point temperature °C/°F	
	Mixing ratio at saturation (100%) g/kg	
	Volume fraction of water vapour / mass fraction of water vapour (%)	
	Wet-bulb temperature °C/°F	
	Ice-bulb temperature °C/°F	
	Specific Enthalpy (mass of air) kJ/kg	
	Saturation vapour pressure above ice/water (hPa)	
	Vapour particle pressure (hPa)	
	Air density kg/m³	
Calculated measurement categories for external airflow sensors	Operating airflow volume - various units: (m³/s) (m³/h) (l/min)	
	Standard airflow volume: DIN 1343 (°C, 1013.25hPa), ISO 2533 (15°C, 1013.25hPa), DIN 1945 (20°C, 1013.25hPa)	
	Various units: (m³/s), (m³/min), (m³/h), (l/min)	
Compatibility	Sensor/probe: all SDI/digital sensors (temperature, humidity, SDI airflow, air pressure integrated)	
Accessories	Extension and/or connecting cable for digital sensor, 2m	8120.KAB2
	Extension and/or connecting cable for digital sensor, 10m	8120.KAB10

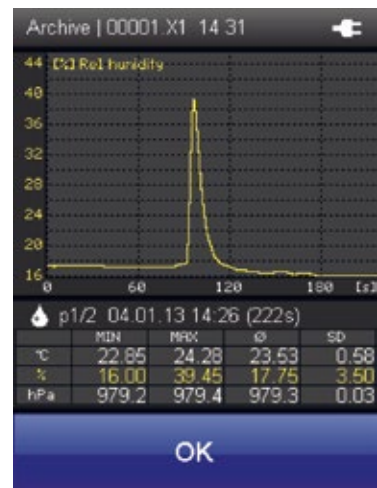

Compatible sensors for XA1000		Page
Temperature/humidity	Digital TFF20	24
	Allround SDI	24
	5 mm diameter SDI	25
	High temperature SDI	25
	High-precision Temperature/Humidity Sensor	26
Airflow/temperature	SDI (0...2m/s)	27
	SDI (0...20m/s)	27
CO₂	CO ₂ Sensor	26

A high utility item combining elegant design with ease of use.

X(per) P(rofessional) Series

XP100

- TFT LCD , anti-glare colour display
- Capacitive touch screen
- Sampling rate 1s
- Data recording
- Graphical analysis including standard deviation
- Integrated flash memory with space for up to 200 data blocks, or up to three hours continuous recording
- USB port for data transfer to Smartgraph 3 (included in delivery)
- Multilingual interface
- Online firmware update



Hand-held measuring device XP100 for measuring temperature (-200...+800°C)



High-precision hand-held device for PT100 temperature sensors. Suitable for measuring tasks requiring a high degree of precision. Mini USB port with software and online data collection. 25 languages available, accuracy is 0.01°C across the full measuring range. Solely for use with PT100 sensors.

Hand-held device XP100		Order No.
Very exact temperature measuring device (±0.01°C). Ideal as a reference device and for comparison measurements in service or as part of ISO9000 tasks. We recommend a DAkkS calibration certificate for traceability to international standards.		5810.00
Technical data	Dimensions	170x62x34 mm
	Weight	Approx. 205g
Storage conditions	Permitted ambient temperature	-20...60°C
	Permitted rel. humidity	<90% RH non-condensing
Operating conditions	Permitted rel. humidity	<90% RH non-condensing
Power supply	Power supply	4 Alkaline LR6 AA 1.5V / USB 5V
	Active power consumption	Approx. 400mW
	Battery life passive	Approx. 1 year
	Battery life active	Min. 24 hours
Data storage	Integrated data storage	Up to 200 data/approx. 1 Mio measured values
Interface	USB	Cable and SmartGraph3 software included in delivery
Resolution	Definition of measured values	3 decimal places
Display	Control	Touch screen, capacitive
	Technology	TFT, resolution 240x320, 65k colours, very good contrast, suitable for sunlight
	Surface, toughened glass	Degree of hardness: 7, scratch-resistant
Accessories	Extension and/or connecting cable for digital sensor, 2m	8120.KAB2
	Extension and/or connecting cable for digital sensor, 10m	8120.KAB10
	Power supply adapter	8120.NT
	Connector for third-party sensors	3120.50

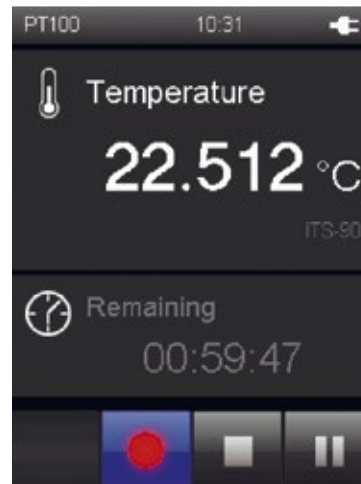

Measurement recording

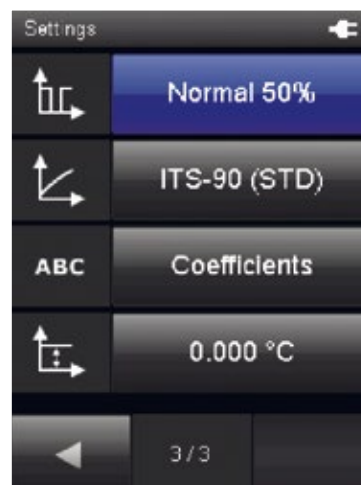

Selection measuring menu

Compatible sensors for XP100		Page
Temperature	PT100 surface probe	23
	PT100 probe/ immersion probe (long)	22
	PT100 food probe, stainless steel	22
	Immersion probe 300x4mm	22

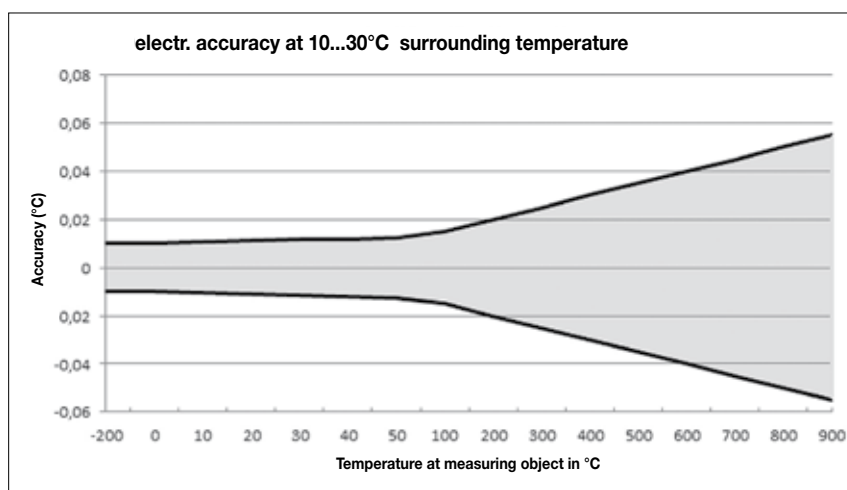



Measurement recording

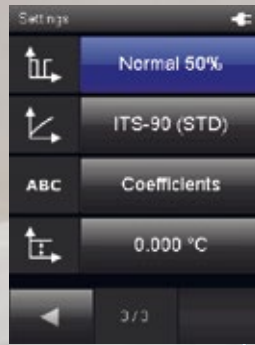

Selection measuring menu

Ideal as reference standard

X(per) P(rofessional) Series

XP101

- TFT LCD , anti-glare colour display
- Capacitive touch screen
- Sampling rate 1s
- Data recording
- Graphical analysis including standard deviation
- Integrated flash memory with space for up to 200 data blocks, or up to three hours continuous recording
- USB port for data transfer to Smartgraph 3 (included in delivery)
- Multilingual interface
- Online firmware update



Temperature measuring device XP101

0.005°C accuracy



High-precision reference measurement standard for industrial temperature calibrations. Suitable as temperature reference in block calibrators, climate chambers or liquid baths. Mini USB interface with software, online data collection.

Hand-held device XP101		Order No.
<p>The most accurate handheld device (0.005°C) for temperature. Ideal as reference standard. Excellent stability through multiple annealing cycles. Sensor characteristic curve is determined individually and is saved in the device. Integrated root 2 function for determination of the sensor self-heating, plus automatic elimination of parasitic thermovoltage. For traceability to national standards a DAkkS calibration certificate is attached.</p>		5810.10
Technical data	Dimensions	170x62x34 mm
	Weight	Approx. 205g
Temperature	Measurement range	-150...450°C
	Accuracy	0.005°C at 0.005°C otherwise -40...+200°C 0.02°C
	Measuring technique	Four terminal sensing
	Reaction time	10s
Measuring current in normal operation	1 mA DC with duty cycle of 50% = 0.50 mA, 1.85 measurements/sec. Automatic elimination of thermo voltage	
Measuring current "root 2 function"	1 mA DC with duty cycle of 33% = 0.30 mA, 1.25 measurements/sec. Automatic elimination of thermo voltage	
Integrated sensor characteristic curves	DIN EN IEC 60751 / ITS-90 or XP101-mode	
Storage conditions	Permitted ambient temperature	-20...60°C
	Permitted rel. humidity	<90% RH non-condensing
Operating conditions	Permitted rel. humidity	<90% RH non-condensing
	Permitted altitude above sea level	4000m
	Power supply	4 Alkaline LR6 AA 1.5V / USB 5V
Power supply	Active power consumption	Approx. 400mW
	Battery life passive	Approx. 1 year
	Battery life active	Min. 24 hours
	Sensor power supply	5.5V ± 10% DC, max. 200mA
Data storage	Integrated data storage	Up to 200 data/approx. 1 Mio measured values
	Interface	USB Cable and SmartGraph3 software included in delivery
Resolution	Definition of measured values	3 decimal places
Display	Control	Touch screen, capacitive
	Technology	TFT, resolution 240x320, 65k colours, very good contrast, suitable for sunlight
	Surface, toughened glass	Degree of hardness: 7, scratch-resistant
Accessories	Extension and/or connecting cable for digital sensor, 10m	8120.KAB10
	Power supply adapter	8120.NT



High quality wooden case and PT100 ceramic sensor are included in delivery

PT100 (immersion) probe, long		Order No.
<p>Precision PT100, ceramic sensor, bifilar coiled, mineral insulated version</p>		3120.700
Technical data	Dimensions, probe	300 x 4 mm
	Dimensions, housing	119 x 27/35 mm
	Weight	120g
	Protective housing	IP40
	Max. permitted operating temperature	PUR cable and handle can be used up to 80°C
Compatibility	XP100, XP101	

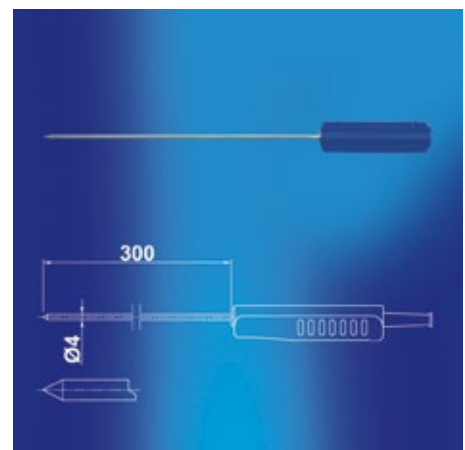

Genuine glass surface with high resolution colour display

X(per) P(rofessional) Series XP200/XP201



- TFT LCD, anti-glare colour display
- Capacitive touch screen
- Sampling rate 1s
- Data recording simultaneously on up to 3 channels
- Graphical analysis including standard deviation
- Integrated flash memory with space for up to 200 data blocks, or up to three hours continuous recording
- USB port for data transfer to Smartgraph 3 (included in delivery)
- Multilingual interface
- Numerous dimensions calculated
- Online firmware update

Hand-held measuring device XP200/ XP201 for measuring temperature and humidity



X-pert range for humidity and temperature measurements in climate and environmental technology.

Hand-held measuring device XP200			Order No.
Temperature and humidity measuring device compatible with various intelligent sensors.			5820.00
Technical data	Dimensions	170x62x34 mm	
	Weight	Approx. 205g	
Storage conditions	Permitted ambient temperature	-20...60°C	
	Permitted rel. humidity	<90% RH non-condensing	
Operating conditions	Permitted rel. humidity	<90% RH (20g/m ³) non-condensing	
	Permitted altitude above sea level	4000m	
	Power supply	Power supply	
	Active power consumption	Approx. 400mW	
	Battery life passive	Approx. 1 year	
	Battery life active	Min. 24 hours	
	Sensor power supply	5.5V ± 10% DC, max. 200mA	
Data storage	Integrated data storage	Up to 200 data/approx. 1 Mio measured values	
Interface	USB	Cable and SmartGraph3 software included	
Resolution	Definition of measured values	2 decimal places	
Display	Control	Touch screen, capacitive	
	Technology	TFT, resolution 240x320, 65k colours, very good contrast due to Piezoresistive technology	
	Surface, toughened glass	Degree of hardness: 7, scratch-resistant	
Integrated air pressure sensor	Measuring range (full accuracy)	800...1,100mbar	
	Accuracy at 25°C, 1013.25mbar	0.5mbar	
	Long-term stability	typ. - 1mbar/year	
	Measurement resolution	0.024mbar	
	Measuring principle	Piezoresistive	
Calculated measurement categories for external temperature/humidity sensors	Mathematical:	MIN/MAX/AVG/HOLD	
	Temperature (°C/°F)		
	Rel. humidity (% RH)		
	Rel. humidity of ice (% RH)		
	Water vapour density (absolute humidity) g/m ³		
	Dew point temperature °C/°F		
	Frost point temperature °C/°F		
	Mixing ratio at saturation (100%) g/kg		
	Volume fraction of water vapour /mass fraction of water vapour (%)		
	Wet-bulb temperature °C/°F		
	Ice-bulb temperature °C/°F		
	Specific Enthalpy (mass of air) kJ/kg		
	Saturation vapour pressure above ice/water (hPa)		
	Water vapour particle pressure (hPa)		
	Air density kg/m ³		
Accessories	Extension and/or connecting cable for digital sensor, 2m	8120.KAB2	
	Extension and/or connecting cable for digital sensor, 10m	8120.KAB10	



XP201 Order No. 5810.20
High quality wooden case and High-precision Temperature/Humidity Sensor Order No.8130.TFF from page 26 are included in delivery.

Compatible sensors for XP200		Page
Temperature/humidity	Digital TFF20	24
	High-precision Temperature/Humidity Sensor	26
	Allround SDI	24
	5 mm diameter SDI	25
	High temperature SDI	25
CO₂	CO ₂ Sensor	26

Flow measurements with time chart on a high resolution display

X(per) P(rofessional) Series

XP400



- TFT LCD, anti-glare colour display
- Capacitive touch screen
- Sampling rate 1s
- Data recording simultaneously on up to 3 channels
- Graphical analysis including standard deviation
- Integrated flash memory with space for up to 200 data blocks, or up to three hours continuous recording
- USB port for data transfer to Smartgraph 3 (included in delivery)
- Multilingual interface
- Current measurement via external, digital sensors
- Integrated atmospheric pressure measurement ability
- Numerous dimensions calculated
- Online firmware update

Hand-held measuring device XP400 for measuring airflow



Ideal for volume measurements, air intake and air discharge measurements in climate measuring technology. Data memory and software.

Hand-held measuring device XP400			Order No.
The X-pert for precise airflow measurements on various measurement ranges.			5840.00
Technical data	Dimensions	170 x 62 x 34 mm	
	Weight	Approx. 205g	
Storage conditions	Permitted ambient temperature	-20...60°C	
	Permitted rel. humidity	<90% RH non-condensing	
Operating conditions	Permitted rel. humidity	<90% RH (20g/m³) non-condensing	
	Permitted altitude above sea level	4000m	
	Power supply	4 Alkaline LR6 AA 1.5V / USB 5V	
	Active power consumption	Approx. 400mW	
	Battery life passive	Approx. 1 year	
	Battery life active	Min. 24 hours	
	Sensor power supply	5.5V ± 10% DC, max. 200mA	
Data storage	Integrated data storage	Up to 200 data/approx. 1 Mio measured values	
Interface	USB	Cable and SmartGraph3 software included in delivery	
Resolution	Definition of measured values	2 decimal places	
Display	Control Technology	Touch screen, capacitive TFT, resolution 240x320, 65k colours, very good contrast due to Piezoresistive technology	
	Surface, toughened glass	Degree of hardness: 7, scratch-resistant	
Integrated air pressure sensor	Measuring range (full accuracy)	800...1,100mbar	
	Accuracy at 25°C, 1013,25mbar	0.5mbar	
	Long-term stability	typ. - 1mbar/year	
	Measurement resolution	0.024mbar	
	Measuring principle	Piezoresistive	
Calculated measurement categories for external airflow sensors	Operating airflow volume - various units: (m³/s) (m³/h) (l/min)		
	Standard airflow volume: DIN 1343 (°C, 1013,25hPa), ISO 2533 (15°C, 1013,25hPa), DIN 1945 (20°C, 1013,25hPa)		
	Various units: (m³/s), (m³/min), (m³/h), (l/min)		
Accessories	Extension and/or connecting cable for digital sensor, 2m	8120.KAB2	
	Extension and/or connecting cable for digital sensor, 10m	8120.KAB10	

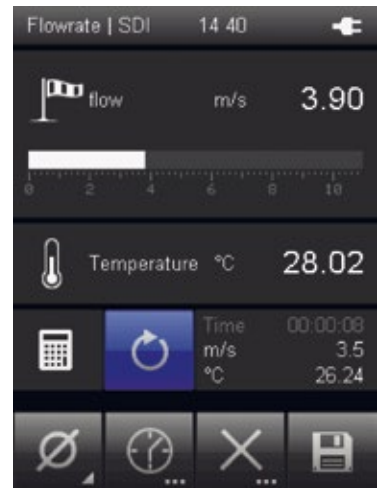
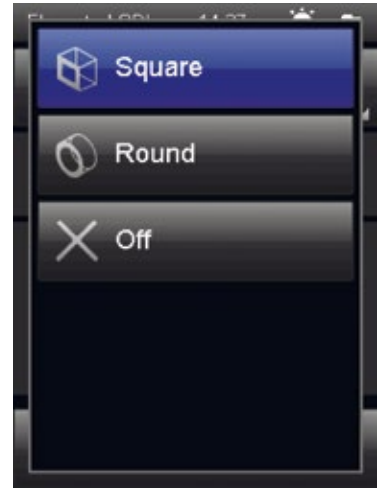

Compatible sensors for XP400		Page
Flow/	SDI (0...2m/s)	27
Temperature	SDI (0...20m/s)	27



More Information Lufft X-Series
www.lufft-xseries.com

Measuring devices
with high
resolution display

(e)XC(lusiv) Series

XC200



- Two lines color display with large digits
- Accurate measurement of temperature and relative humidity
- Calculation of dew point temperature of the ambient air
- Calculation of mixed ratio
- Display of MAX, MIN, HOLD, AVG and ACT, easily selectable
- Easy-to-use touch operations (capacitive)
- USB interface for SmartGraph3 software
- Easy to use
- Calibration certificate

Hand-held measuring device XC200 for measuring temperature and humidity



The powerful and compact handheld device with state-of-the-art and robust design. Excellent accuracy. The high-resolution color screen displays rel. humidity, temperature and dew point. Excellent readability. The calibration function (offset correction) guarantees the long-term use without compromising the accuracy.

Hand-held measuring device XC200		Order No.
Excellent accuracy of temperature and relative humidity. Display of calculations and statistical functions. Adjustment of local pressure and local height possible. Calibration function and offset correction. Including a calibration certificate. USB interface with SmartGraph3 software.		5700.00
Technical data	Dimensions	170x60x35 mm
	Weight	Approx. 250g
	Temperature Sensor	NTC
	Measurement range	-20...50°C
	Accuracy	± 0.2°C (0...40°C) otherwise ± 0.4°C
	Resolution	0.1°C
	Humidity Sensor	Capacitive
	Measurement range	0...100% RH
	Accuracy	± 2% RH
	Resolution	0.1% RH
Calculations	Dew point temperature °C or °F Absolute humidity g/m ³ Mixed ratio g/kg or gr/lb	
Functions	Statistical calculations MAX, MIN, HOLD, AVG, ACT, Temperature correction and humidity correction factors (offset) Power saving functions	
Storage conditions	Permitted ambient temperature	-20...60°C
	Permitted rel. humidity	<95% RH non-condensing
Operating conditions	Permitted ambient temperature	-20°C...50°C
	Permitted rel. humidity	<90% RH
	Permitted altitude above sea level	3000m
Power supply	Power consumption	5.5V ± 10% DC, max 200mA
	Active power consumption	Approx. 70mA
	Passive power consumption	Approx. 40µA
	Battery life	Approx. 24h (2.6Ah battery capacity)
Warranty	12 months	
Accessories	Case for hand-held-measuring device	5800.BAG
	Stainless steel sinter filter	5120.212



Customized measurement display

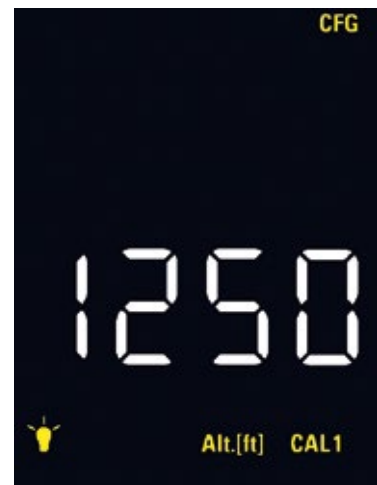

Altitude configuration



Hold function

Measuring devices
with with high
resolution display

(e)XC(lusiv) Series

XC250

- Precision of the xc200 combined with a high-precision pyrometer ($\pm 0,5^{\circ}\text{C}$ @ 0°C ... 50°C)
- Noncontact temperature measurement
- Continuous measurand output of the thermopile to the LCD
- Adjustable emissivity, to adapt to different surfaces
- Pyrometer is laser assisted
- Configurable condensation/dew alarm with contact-free measurements (Application: e.g. detect molds)
- Two lines color display with large digits
- Accurate measurement of temperature and relative humidity
- Calculation of dew point temperature of the ambient air
- Calculation of mixed ratio
- Display of MAX, MIN, HOLD, AVG and ACT, easily selectable
- Easy-to-use touch operations (capacitive)
- USB interface for SmartGraph3 software
- Calibration certificate



Hand-held measuring device XC250

Pyrometer Temperature/Humidity



The powerful and compact handheld device with state-of-the-art and robust design. Excellent accuracy. The high-resolution color screen displays rel. humidity, temperature and dew point. Excellent readability. The calibration function (offset correction) guarantees the long-term use without compromising the accuracy.

Special features: Contact-free temperature measurement

Hand-held measuring device XC250		Order No.
Excellent accuracy of temperature and relative humidity. Contact-free temperature measurement. Display of calculations and statistical functions. Adjustment of local pressure and local height possible. Calibration function and offset correction. Including a calibration certificate. USB interface with SmartGraph3 software.		5725.00
Technical data	Dimensions	170x60x35 mm
	Weight	Approx. 250g
Temperature Sensor	Principle	NTC
	Measurement range	-20...50°C
	Accuracy	± 0.2°C (0...40°C) otherwise ± 0.4°C
	Resolution	0.1°C
Surface temperature	Principle	Thermopile
	Measurement range	-70 ... 380 °C
	Unit	°C
	Accuracy	± 0.5°C (0...50°C) otherwise ± 4°C
	Resolution	0.1
Humidity Sensor	Principle	Capacitive
	Measurement range	0... 100% RH
	Accuracy	± 2% RH
	Resolution	0.1% RH
	Calculations	Dew point temperature °C or °F Absolute humidity g/m³ Mixed ratio g/kg or gr/lb
	Functions	Statistical calculations MAX, MIN, HOLD, AVG, ACT. Temperature correction and humidity correction factors (offset)
Storage conditions	Permitted ambient temperature	-20...60°C
	Permitted rel. humidity	<95% RH non-condensing
Operating conditions	Permitted ambient temperature	-20°C...50°C
	Permitted rel. humidity	<90% RH
Power supply	Power consumption	5.5V ± 10% DC, max 200mA
	Stromaufnahme aktiv	Approx. 70mA
	Stromaufnahme passiv	Approx. 40µA
	Batterielebensdauer	Approx. 24h (2.6Ah battery capacity)
Warranty		12 months
Accessories	Case for hand-held-measuring device	5800.BAG
	Stainless steel sinter filter	5120.212

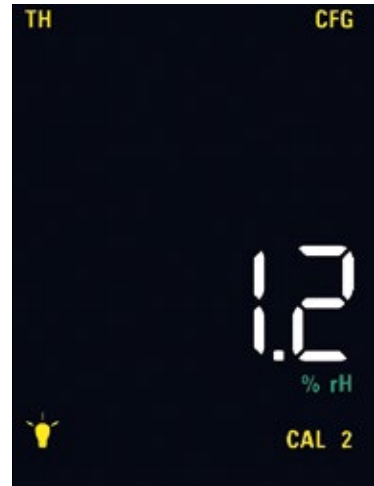

User-offset configuration menu

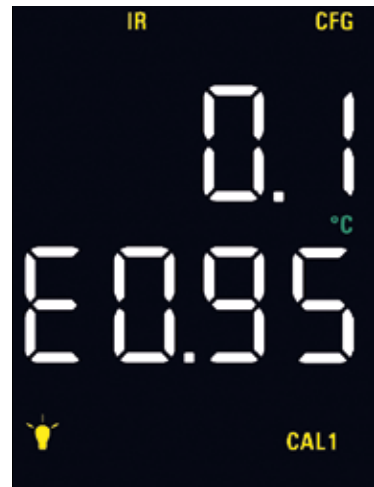

Emissivity configuration



Dew point alarm configuration

	Laser 2
	$\lambda=650\text{nm}$
	$P \leq 1\text{mW}$
	Complies with 21 CFR 1040.10 except for deviations pursuant to Laser Notice No. 50, dated June 24, 2007

More Information Lufft X-Series
www.lufft-xseries.com

PT100 immersion probe

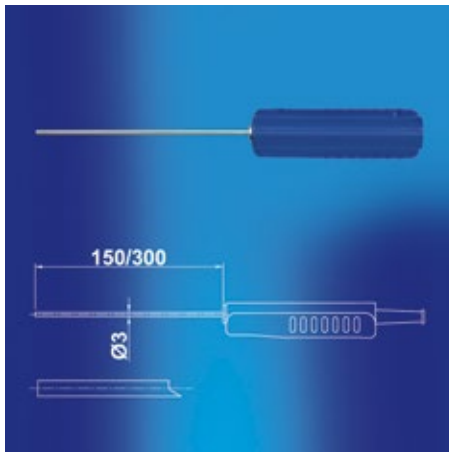

PT100 immersion probe		Order No.	
The immersion probe is suitable for measurements in gaseous media, liquids and granular material, such as sand.			
Technical data	Dimensions, probe, short	150x3 mm	3120.520
	Dimensions, probe, long	300x3 mm	3120.530
Temperature	Dimensions, housing	119x27/35 mm	
	Weight	100g/120g	
	Protective housing	IP40	
	Max. permitted operating temperature	PUR cable and handle can be used up to 80°C	
	Storage temperature	-40 °C...60 °C	
	Measurement range	-40 ... 400 °C	
	Accuracy	±0.15 +0.002 x t	
Compatibility	Measuring technique	4 wire sensing	
	Reaction time	10s	
	XP100		
Accessories	Extension cable for sensor, 2m	8120.KAB2	

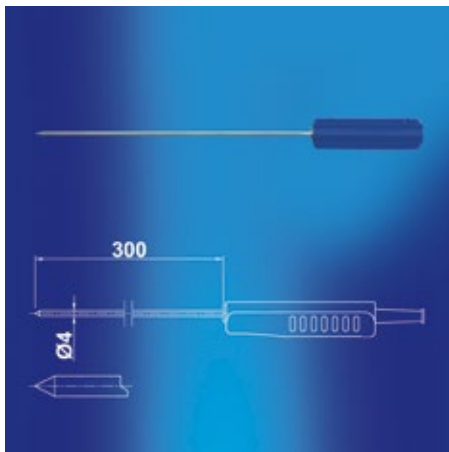

PT100 (immersion) probe, long		Order No.	
This high-precision immersion probe in stainless steel protective housing can also be used as a reference sensor for calibration and testing systems.			
Technical data	Dimensions, probe	300x4 mm	3120.540
	Dimensions, housing	119x27/35 mm	
	Weight	120g	
	Protective housing	IP40	
	Max. permitted operating temperature	PUR cable and handle can be used up to 80°C	
Temperature	Measurement range	-40 ... 400 °C	
	Accuracy	±0,03 + 0,002 x t	
	Measuring technique	Four terminal sensing	
	Reaction time	10s	
Compatibility	XP100		
Accessories	Extension and/or connecting cable for digital sensor, 2m	8120.KAB2	

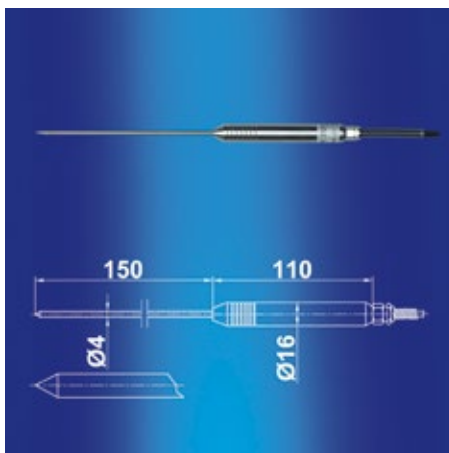

PT100 stainless steel food probe		Order No.	
Food probe in stainless steel protective casing for precise temperature measurements (PT100 1/10 class B).			
Technical data	Dimensions, probe	150x4 mm	3120.550
	Dimensions, housing	110x16 mm	
	Weight	220g	
	Protective housing	IP65	
	Max. permitted operating temperature	PUR cable and handle can be used up to 80°C	
	Lagertemperatur	-40 °C...60 °C	
	Temperature	Measurement range	-40 ... 400 °C
Accuracy		±0,03 + 0,002 x t	
Measuring technique		Four terminal sensing	
Reaction time		10s	
Cable length		Approx. 1m	
Compatibility	XP100		

PT100 surface probe



PT100 surface probe		Order No.
At the head of the surface temperature probe is a spring-loaded sensor which takes the temperature. Can be used on flat, matt and metallic surfaces		3120.600
Technical data	Dimensions, probe	150x4,5mm
	Dimensions, housing	119x27/35mm
	Weight	120g
	Protective housing	IP40
	Max. permitted operating temperature	PUR cable and handle can be used up to 80°C
Temperature	Measurement range	-50 ... 400 °C
	Accuracy	±0.3 + 0.005 x t
	Reaction time t90	Approx. 30s
	Measuring technique	Four terminal sensing
Compatibility	XP100	
Accessories	Extension and/or connecting cable for digital sensor, 2m	8120.KAB2

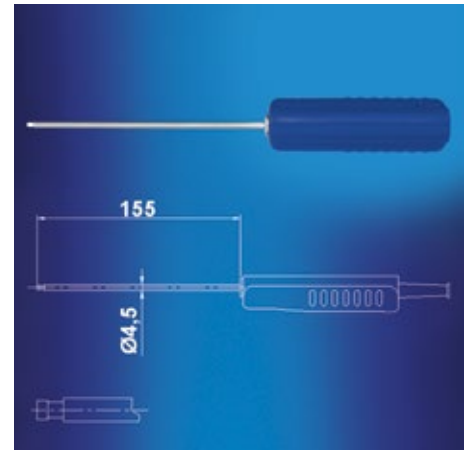

Immersion probe		Order No.
Accuracy with PT100 1/10 DIN 8 in stainless steel protective casing, mineralized sleeve.		3120.560
Technical data	Dimensions, probe	150x4 mm
	Dimensions, housing	119x27/35mm
	Weight	120g
	Protective housing	IP40
	Max. permitted operating temperature	PUR cable and handle can be used up to 80°C
	Storage temperature	-40 ... 60 °C
Temperature	Measurement range	-40 ... 400 °C
	Accuracy	±0,03 + 0,002 x t
	Reaction time	10s
	Measuring technique	4 wire sensing
Compatibility	XP100	
Accessories	Extension and/or connecting cable for digital sensor, 2m	8120.KAB2

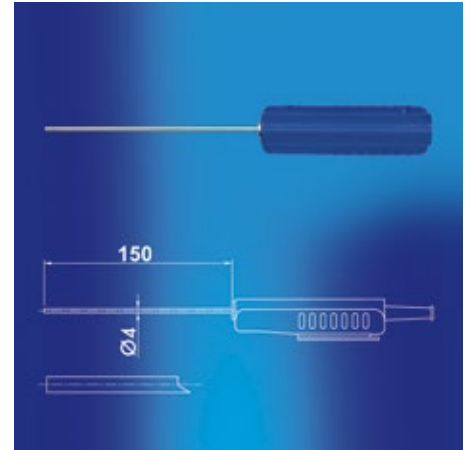

Temperature probe		Order No.	
Temperature sensor 10m cable		8160.TF	
Technical data	Dimensions	Length 50mm, Ø 6mm	
	Output signal	Resistance	
	Weight	370g	
	Cable length	50m	
	Protection type	IP68	
	Connector	COMBICON Phönix	
	Operating temp.	-50...150°C	
	Operating rel. humidity	0...100% RH	
	Accuracy	Class A	
	Temperature	Principle	PT100
		Measuring range	-50 ... 150 °C
Accuracy		±0,2K@0°C	

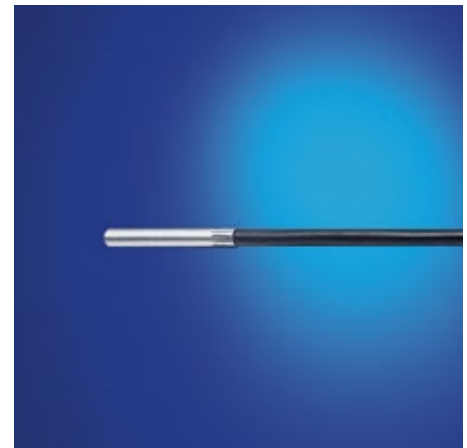

Temperature/Humidity Sensor



Digital TFF20			Order No.
<i>Reference measurement in service and maintenance, suitable for measurements in air conditioning and heating industry segments.</i>			8120.TFF
Technical Data	Dimensions	Length 85 mm, Ø 12 mm	
	Weight	Approx. 50g	
	Protection	Polycarbonate / IP65	
	Permitted operation temp.	0...50°C	
	Permitted humidity	0...100% RH	
	Storage temperature	-20...60°C	
	Storage humidity	20...80% RH	
	Relative Humidity	Measurement range	0... 100% RH
Accuracy		± 2 % (0 ... 90 %), ± 3 % (90 ... 100 %) RH	
Resolution		0.01 % RH	
Principle		Capacitive	
Temperature	Measurement range	- 40 ... 80 °C	
	Accuracy (20°C)	± 0.1 °C	
	Accuracy (0...40°C)	± 0.2 °C otherwise ± 0.5 °C	
	Resolution	0.01 °C	
	Principle	PT1000, Class A, DIN EN 60751	
Absolute Humidity	Measurement range	0...300g/m ³	
	Unit	g/m ³	
Dew Point Temp.	Measurement range	-40...80°C	
Mixing Ratio	Measurement range	0...550g/kg	
Compatibility	XA1000, XP200, OPUS20E		
Accessories	Stainless steel sinter cap		5120.212
	Calibration salt 11,3% RH		5700.113
	Calibration salt 32,8% RH		5700.328
	Calibration salt 52,9% RH		5700.529
	Calibration salt 75,3% RH		5700.753
	Calibration salt 90,1% RH		5700.901
	Calibration adapter		8120.ADAP

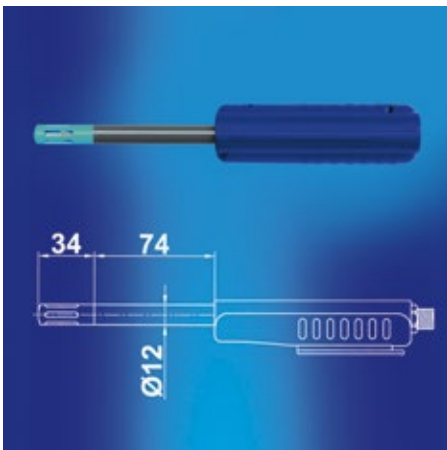

Allround SDI Temperature/Humidity Sensor			Order No.
<i>Compact temperature-/humidity sensor, in stainless steel tube. Application in HVAC field, reference measurement in accordance with ISO9000 Quality Assurance</i>			9130.540
Technical Data	Dimensions Sensor	Length 74 mm, Ø 12 mm	
	Dimensions Housing	117 x 38 mm	
	Weight	Approx. 80g	
	Protection	Housing/Sensor IP40 Sensor head plastic mesh	
	Permitted operation temp.	0...50°C	
	Permitted humidity	0...100% RH	
	Storage temperature	-20...60 °C	
	Storage humidity	20...80% RH	
Relative Humidity	Measurement range	0... 100% RH	
	Accuracy	± 2 % (0 ... 90 %), ± 3 % (90 ... 100 %) RH	
	Resolution	0.1 % RH	
	Principle	Capacitive	
Temperature	Measurement range	-20 ... 70 °C	
	Accuracy (20°C)	± 0.2 °C	
	Accuracy (-10...50°C)	± 0.4 °C otherwise ± 0.5 °C	
	Resolution	0.1 °C	
	Principle	NTC	
Compatibility	XA1000, XP200		
Accessories	Stainless steel sinter cap		5120.212
	Extension and/or connecting cable for digital sensor, 2m		8120.KAB2
	Calibration salt 11,3% RH		5700.113
	Calibration salt 32,8% RH		5700.328
	Calibration salt 52,9% RH		5700.529
	Calibration salt 75,3% RH		5700.753
	Calibration salt 90,1% RH		5700.901
	Calibration adapter		8120.ADAP

Temperature/Humidity Sensor



SDI Temperature-/Humidity Sensor with 5mm Diameter		Order No.
Compact, slim temperature-/humidity sensor in stainless steel protective tube. With a diameter of only 5mm, the sensor is suitable for applications in measurement areas that are difficult to access.		9130.520
Technical Data	Dimensions sensor tube	Length 250mm, Ø 5mm
	Dimensions housing	117 x 38 mm
	Weight	Approx. 85g
	Protection	Housing/sensor IP40 sensor head: screwable, stainless steel cap, PTFE filter
	Permitted operation temp.	0...50°C
	Permitted humidity	0...100% RH
	Storage temperature	-20...60°C
	Storage humidity	20...80% RH
	Relative Humidity	Measurement range
Accuracy		±2 % (0 ... 90 %), ±3 % (90 ... 100 %) RH
Resolution		0.1% RH
Principle		Capacitive
Temperature	Measurement range	-40 ... 100 °C
	Accuracy	±0.2°C at 20 °C otherwise ±0.7°C
	Resolution	0.1°C
	Principle	PT1000 (tolerance class B, DIN EN 60751)
Compatibility	XA1000, XP200	
Accessories	Extension and/or connecting cable for digital sensor, 2m	8120.KAB2
	Calibration salt 11,3% RH	5700.113
	Calibration salt 32,8% RH	5700.328
	Calibration salt 52,9% RH	5700.529
	Calibration salt 75,3% RH	5700.753
	Calibration salt 90,1% RH	5700.901
	Calibration adapter	5700.A06

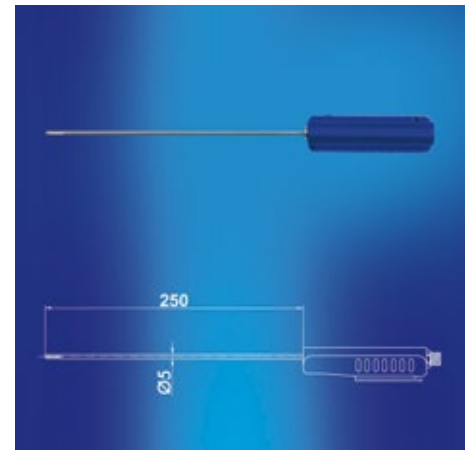

SDI High Temperature-/Humidity Sensor		Order No.
Stainless steel sensor equipped with a Teflon probe is especially suitable for high temperature/humidity measurements.		9130.530
Technical Data	Dimensions sensor tube	Length 250mm, Ø 12mm
	Dimensions housing	117 x 38 mm
	Weight	Approx. 200g
	Protection	Housing/sensor IP40 sensor head: stainless steel sinter filter
	Permitted operation temp.	0...50°C
	Permitted humidity	0...100% RH
	Storage temperature	-20...60°C
	Storage humidity	20...80% RH
	Relative Humidity	Measurement range
Accuracy		±2 % (0 ... 90 %), ±3 % (90 ... 100 %) RH
Resolution		0.1% RH
Principle		Capacitive
Temperature	Measurement range	-40...180°C (grip of sensing probe up to 80°C)
	Accuracy	±0.2°C at 20 °C otherwise ±0.7°C
	Resolution	0.1°C
	Principle	PT1000 (tolerance class B, DIN EN 60751)
Compatibility	XA1000, XP200	
Accessories	Extension and/or connecting cable for digital sensor, 2m	8120.KAB2
	Calibration salt 11,3% RH	5700.113
	Calibration salt 32,8% RH	5700.328
	Calibration salt 52,9% RH	5700.529
	Calibration salt 75,3% RH	5700.753
	Calibration salt 90,1% RH	5700.901
	Calibration adapter	8120.ADAP

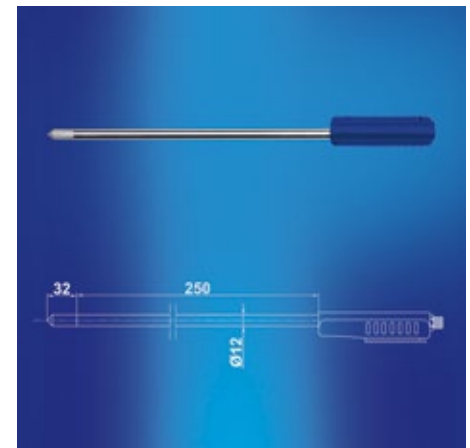

More Information Lufft X-Series
www.lufft-xseries.com

XA1000
XP200



Temperature/Humidity Sensor



High-precision Temperature/Humidity Sensor			Order No.
High-precision Temperature/Humidity Sensor			8130.TFF
Technical data	Measurement accuracy incl. reproducibility and hysteresis	Humidity*: 15...30°C, ±0,5% RH 0...50°C, ±0,8% RH -20...80°C, ±2,5% RH	
	Temperature	Measuring range Operating temperature Storage temperature Principle Accuracy	-20...80°C -20...80°C -10...60°C (non-condensing) NTC 0,15°C between 0...+70°C, otherwise 0,25°C
Relative humidity	Principle	Resistive-electrolytic	
	Measuring range	0 ... 100 %	
Housing	Material	PVDF black	
	Mechanical sensor protection	Standard polyethylene dust filter	
Compatibility	XA1000, XP200, OPUS20E		
Accessories	Calibration salt 11,3% RH		5700.113
	Calibration salt 32,8% RH		5700.328
	Calibration salt 52,9% RH		5700.529
	Calibration salt 75,3% RH		5700.753
	Calibration salt 90,1% RH		5700.901
	Calibration adapter		5700.A13

* The humidity accuracy refers to the nominal values of Novasina humidity standards, which refer to the Greenspan Report.

CO₂ Sensor



The CO₂ probe is designed for use in harsh, demanding OEM applications. A multiple point CO₂ and temperature adjustment procedure leads to excellent CO₂ measurement accuracy over the entire temperature working range, ideal for use in agriculture or outdoors for instance. The probe incorporates the dual wavelength NDIR CO₂ sensor, which compensates for ageing effects, is highly insensitive to pollution and stands for outstanding long term stability. The measured data range of up to 10000ppm is available on the Modbus or on the E2 digital interface. An optional kit facilitates easy configuration and adjustment. The measurement interval can be set according to the application requirements, by this the average current consumption can be reduced to 120µA for battery-operated devices.

CO ₂ Sensor			Order No.
CO₂ Sensor			7120.CO2
Technical data	Dimensions	Length 96 mm, Ø 18.5 mm	
	Operating temp.	-40...60°C	
	Operating humidity range	0...100% RH (non-condensing)	
	Admissible air pressure	850...1100hPa	
	Storage temp.	-40...60°C	
	Storage humidity	0...100% RH (non-condensing)	
	Storage pressure	700...1100hPa	
	Temperature dependency	typ. 1ppm CO ₂ °C (-20...45°C)	
	Outputs	Digital RS485-BUS	
	Power supply	4,75...7,5V DC, max. 350mA for 0.05s	
	Electrical connection	Connector M12	
CO₂	Electromagnetic compatibility (Industrial environment)	EN61326-1 EN61326-2-3	
	Principle	Dual wavelength, non-dispersive infrared technology (NDIR)	
	Measuring range Accuracy	0 ... 5000 ppm at 25°C and 1013mbar: < ±50ppm +3% of measuring value (for averaging output)	
Housing	Material	Plastic PC	
	Protection level	IP65	
Compatibility	XA1000, XP200		
Accessories	Y Connector for Temperature/Humidity and CO ₂ sensor (IAQ-Indoor Air Quality Measurement)		8120.STY

More Information Lufft X-Series

www.lufft-xseries.com

SDI Airflow-/Temperature Sensor (0...2m/s) (0...20m/s)



SDI Airflow-/Temperature Sensor (0...2m/s)		Order No.
Reference device for airflow and temperature measurements in service and maintenance. Proof of air tightness of buildings and rooms.		6120.510
Technical data	Dimensions sensor tube	Length 200mm, Ø 6mm
	Dimensions housing	117x38mm
	Weight	Approx. 200g
	Protection	Housing: plastic (ABS) IP40 sensor head: stainless steel
	Permitted operation temp.	0...50°C
	Permitted humidity	0...95% RH
	Storage temperature	-20...60°C
	Storage humidity	20...80% RH
Airflow	Measurement range	0...2m/s
	Accuracy	±(0.08m/s + 1% of measured value)
	Resolution	0.01 m/s
	Principle	Hot film anemometer
Temperature	Measurement range	-20...70°C
	Accuracy	±0.7°C in the range 0...+50°C
	Resolution	0.1°C
	Principle	NTC
Compatibility	XA1000	
Accessories	Extension and/or connecting cable for digital sensor, 2m	8120.KAB2

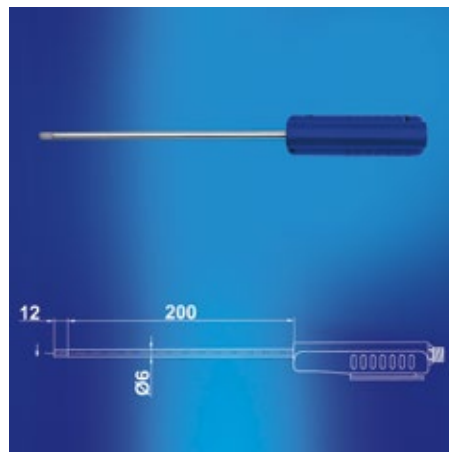

SDI Airflow-/Temperature Sensor (0...20m/s)		Order No.
Application: airflow and temperature measurements in climate measurement technology		6120.520
Technical data	Dimensions sensor tube	Length 200mm, Ø 6mm
	Dimensions housing	117x38mm
	Weight	Approx. 200g
	Protection	Housing: plastic (ABS) IP40 sensor head: stainless steel
	Permitted operation temp.	0...50°C
	Permitted humidity	0...95% RH
	Storage temperature	-20...60°C
	Storage humidity	20...80% RH
Airflow	Measurement range	0...20m/s
	Accuracy	±(0.2m/s + 2% of measured value)
	Resolution	0.01 m/s
	Principle	Hot film anemometer
Temperature	Measurement range	-20...70°C
	Accuracy	±0.7°C in the range 0...+50°C
	Resolution	0.1°C
	Principle	NTC
Compatibility	XA1000	
Accessories	Extension and/or connecting cable for digital sensor, 2m	8120.KAB2

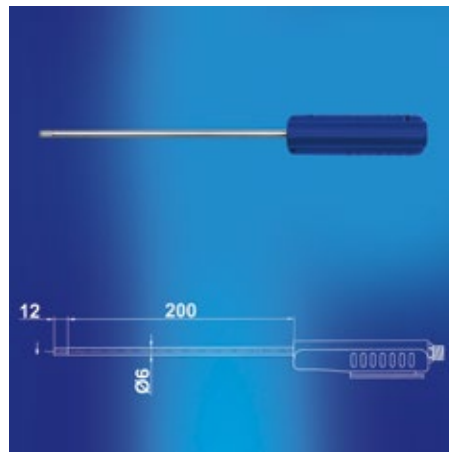

The world's toughest legal guidelines: 21 CFR Part 11 (electronic records).

The pharmaceutical industry trusts in Lufft.

Eliminate Fatal Consequences

OPUS20 Data logger: threshold values always under control



Lufft OPUS20 Functions



Functions	THI 8120.00	THIP 8120.10	TCO 8120.20	Lufft OPUS20 E 8120.30
Power supply battery	■	■	■	■
Power supply USB	■	■	■	■
Power supply LAN (POE)	optional	optional	optional	optional
Measured data storage	3,200,000	3,200,000	3,200,000	3,200,000
Typical battery life	> 1 year	> 1 year	> 4 months	> 4 months
LC-display	■	■	■	■
One-button operation	■	■	■	■
1-point calibration by user/operator	■	■	■	■
°C/°F switchable	■	■	■	■
Optical/acoustical alarm	■	■	■	■
Date/time	■	■	■	■
Records Min/Max/Avg.	■	■	■	■
SmartGraph 3 evaluation software	■	■	■	■
Measurement Categories	THI 8120.00	THIP 8120.10	TCO 8120.20	Lufft OPUS20 E 8120.30
Temperature				
Air temperature	■	■	■	■*
PT100				■**
Thermocouple				■**
Humidity				
Relative humidity	■	■	■	■*
Absolute humidity	■	■	■	■*
Dew point temperature	■	■	■	■*
Mixture ratio				■*
Air pressure				
Barometric air pressure		■		■*
Relative air pressure		■		■*
CO₂ Concentration				
CO ₂ Concentration			■	
External BUS-enabled digital sensor				
TFF20				■
External analog input				
Sensor input voltage				■***
Sensor input electric current				■***
Function Table Software	THI 8120.00	THIP 8120.10	TCO 8120.20	Lufft OPUS20 E 8120.30
Graphical representation	■	■	■	■
Numerical data (measured value display)	■	■	■	■
Print function	■	■	■	■
Export function for measured values (e.g. Excel)	■	■	■	■
Gathered printouts of all measurement sites	■	■	■	■
Administration of up to 255 measuring devices	■	■	■	■

* via external BUS-enabled sensor, optionally, max. 4 sensors with one OPUS20E

** via external analog sensors, optionally, 2 separate analog inputs

*** near analog/digital conversion of 0...1V, 0/4 ... 20 ma possible

THI



THIP



TCO



Lufft OPUS20 E



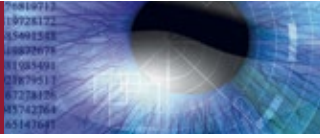

Lufft OPUS20 THI

Temperature and rel. Humidity

For climate monitoring in buildings and the control of all climate-sensitive production processes, in electronic data-processing centres, control cabinets, wind turbines, storage rooms and museums.

The OPUS20 runs on batteries or can be powered via USB. Alternatively, you have the possibility to power the device via POE (Power over Ethernet).

Lufft OPUS20 Temperature and Relative Humidity			Order-No.
Lufft OPUS20 Temperature / rel. Humidity (neutral without Lufft-Logo 8120.00N)			8120.00
Lufft OPUS20 Temperature / rel. Humidity PoE (neutral without Lufft-Logo 8120.01N)			8120.01
Technical data	Dimensions	length 166 mm, width 78 mm, depth 32 mm	
	Measurement rate	10/30s, 1/10/12/15/30min, 1/3/6/12/24h	
	Storage rate	1/10/12/15/30min, 1/3/6/12/24h	
	Construction	plastic housing	
	Operation life (battery)	> 1 Year	
	Data storage	16 MB, 3,200,000 measured values	
	LC-Display	size 90x64 mm	
	Weight	approx. 250g	
	Included in delivery	PC-Windows Software SmartGraph 3 for graphical and numerical representation of measured values / instruction manual/ data cable / battery / DIN rail bracket	
	Interface	USB, LAN	
	Power supply	4 x LR6 AA Mignon, USB, (POE opt.)	
	Max. operation temperature	-20...50°C	
	Max. rel. humidity	0...95% RH<20g/m ³ (non condensing)	
	Max. altitude	10,000 m above sea level	
Temperature	Principle	NTC	
	Measurement range	-20 ... 50 °C	
	Accuracy	±0.3°C (0...40°C), otherwise 0.5°C	
	Resolution	0.1°C	
Rel. humidity	Principle	capacitive	
	Measurement range	0...100% RH	
	Accuracy	±2% RH,	
	Resolution	0.1% RH	
Accessories	4 x LR6 AA Mignon		8120.SV1
	Power supply adapter		8120.NT



The only LAN datalogger with built-in sensors and the highest precision

Lufft OPUS20 THIP Temperature, Rel. Humidity, Air Pressure



Lufft OPUS20 THIP Temperature, Relative Humidity, Air Pressure		Order-No.																												
Lufft OPUS20 THIP Temperature / Rel. Humidity / Air Pressure (neutral without Lufft-Logo 8120.10N)		8120.10																												
Lufft OPUS20 THIP Temperature / Rel. Humidity / Air Pressure PoE (neutral without Lufft-Logo 8120.11N)		8120.11																												
Technical data	<table border="1"> <tr> <td>Dimensions</td> <td>length 166 mm, width 78 mm, depth 32 mm</td> </tr> <tr> <td>Measurement rate</td> <td>10/30s, 1/10/12/15/30min, 1/3/6/12/24h</td> </tr> <tr> <td>Storage rate</td> <td>1/10/12/15/30min, 1/3/6/12/24h</td> </tr> <tr> <td>Construction</td> <td>plastic housing</td> </tr> <tr> <td>Operation life (battery)</td> <td>> 1 Year</td> </tr> <tr> <td>Data storage</td> <td>16 MB, 3,200,000 measured values</td> </tr> <tr> <td>LC-Display</td> <td>size 90x64 mm</td> </tr> <tr> <td>Weight</td> <td>approx. 250g</td> </tr> <tr> <td>Included in delivery</td> <td>PC-Windows Software SmartGraph 3 for graphical and numerical representation of measured values / instruction manual/ data cable / battery / DIN rail bracket</td> </tr> <tr> <td>Interface</td> <td>USB, LAN</td> </tr> <tr> <td>Power supply</td> <td>4 x LR6 AA Mignon, USB, (POE opt.)</td> </tr> <tr> <td>Max. operation temperature</td> <td>-20...50°C</td> </tr> <tr> <td>Max. rel. humidity</td> <td>0...95% RH < 20g/m³ (non condensing)</td> </tr> <tr> <td>Max. altitude</td> <td>10,000 m above sea level</td> </tr> </table>	Dimensions	length 166 mm, width 78 mm, depth 32 mm	Measurement rate	10/30s, 1/10/12/15/30min, 1/3/6/12/24h	Storage rate	1/10/12/15/30min, 1/3/6/12/24h	Construction	plastic housing	Operation life (battery)	> 1 Year	Data storage	16 MB, 3,200,000 measured values	LC-Display	size 90x64 mm	Weight	approx. 250g	Included in delivery	PC-Windows Software SmartGraph 3 for graphical and numerical representation of measured values / instruction manual/ data cable / battery / DIN rail bracket	Interface	USB, LAN	Power supply	4 x LR6 AA Mignon, USB, (POE opt.)	Max. operation temperature	-20...50°C	Max. rel. humidity	0...95% RH < 20g/m ³ (non condensing)	Max. altitude	10,000 m above sea level	
Dimensions	length 166 mm, width 78 mm, depth 32 mm																													
Measurement rate	10/30s, 1/10/12/15/30min, 1/3/6/12/24h																													
Storage rate	1/10/12/15/30min, 1/3/6/12/24h																													
Construction	plastic housing																													
Operation life (battery)	> 1 Year																													
Data storage	16 MB, 3,200,000 measured values																													
LC-Display	size 90x64 mm																													
Weight	approx. 250g																													
Included in delivery	PC-Windows Software SmartGraph 3 for graphical and numerical representation of measured values / instruction manual/ data cable / battery / DIN rail bracket																													
Interface	USB, LAN																													
Power supply	4 x LR6 AA Mignon, USB, (POE opt.)																													
Max. operation temperature	-20...50°C																													
Max. rel. humidity	0...95% RH < 20g/m ³ (non condensing)																													
Max. altitude	10,000 m above sea level																													
Temperature	<table border="1"> <tr> <td>Principle</td> <td>NTC</td> </tr> <tr> <td>Measurement range</td> <td>-20 ... 50 °C</td> </tr> <tr> <td>Accuracy</td> <td>±0.3°C (0...40°C), otherwise 0.5°C</td> </tr> <tr> <td>Resolution</td> <td>0.1°C</td> </tr> </table>	Principle	NTC	Measurement range	-20 ... 50 °C	Accuracy	±0.3°C (0...40°C), otherwise 0.5°C	Resolution	0.1°C																					
Principle	NTC																													
Measurement range	-20 ... 50 °C																													
Accuracy	±0.3°C (0...40°C), otherwise 0.5°C																													
Resolution	0.1°C																													
Rel. humidity	<table border="1"> <tr> <td>Principle</td> <td>capacitive</td> </tr> <tr> <td>Measurement range</td> <td>0...100% RH</td> </tr> <tr> <td>Accuracy</td> <td>±2% RH</td> </tr> <tr> <td>Resolution</td> <td>0.1% RH</td> </tr> </table>	Principle	capacitive	Measurement range	0...100% RH	Accuracy	±2% RH	Resolution	0.1% RH																					
Principle	capacitive																													
Measurement range	0...100% RH																													
Accuracy	±2% RH																													
Resolution	0.1% RH																													
Air pressure	<table border="1"> <tr> <td>Measurement range</td> <td>300 ... 1,300 hPa abs.</td> </tr> <tr> <td>Accuracy</td> <td>700 ... 1,100 mbar at 25°C ±0.5 hPa</td> </tr> <tr> <td>Resolution</td> <td>0.1 hPa</td> </tr> </table>	Measurement range	300 ... 1,300 hPa abs.	Accuracy	700 ... 1,100 mbar at 25°C ±0.5 hPa	Resolution	0.1 hPa																							
Measurement range	300 ... 1,300 hPa abs.																													
Accuracy	700 ... 1,100 mbar at 25°C ±0.5 hPa																													
Resolution	0.1 hPa																													
Accessories	4 x LR6 AA Mignon	8120.SV1																												
	Power supply adapter	8120.NT																												

Finally available: Lufft's precise Climate Station for interior applications – an essential data collector for all calibration laboratories.





Lufft OPUS20 TCO

Temperature, Rel. Humidity, CO₂

The amount of carbon dioxide has been virtually constant at 280 ppm (parts per million) – i.e. 280 gas molecules per million air molecules – the last ten thousand years. However in recent years, this measured value has been increasing rapidly at approx. 2 % per year.

A high level of CO₂ in the air within a room causes headaches, tiredness and lack of concentration. The regulation on CO₂ concentration was established in order to evaluate IAQ (Indoor Air Quality). Normal atmospheric air in so-called ‘clean air areas’ has a level of 360 ppm and approx. 500 ppm in urban areas. The limit of 1,000 ppm (“Pettenkofer Figure”) is still seen as being adequate indoor-air quality, which is especially important when regarding all meetings and conference rooms, as well as schools and open-plan offices.

As a guideline for school rooms in the USA the limit of 1,000 ppm applies; for workplaces the occupational exposure limit is 5,000 ppm.

Lufft OPUS20 TCO / Temperature / Relative Humidity / CO ₂			Order-No.
Lufft OPUS20 TCO / Temperature / Rel. Humidity / CO ₂ (neutral without Lufft-Logo 8120.20N)			8120.20
Lufft OPUS20 TCO / Temperature / Rel. Humidity / CO ₂ POE (neutral without Lufft-Logo 8120.21N)			8120.21
Technical data	Dimensions	length 166 mm, width 78 mm, depth 32 mm	
	Measurement rate	10/30s, 1/10/12/15/30min, 1/3/6/12/24h	
	Storage rate	1/10/30min, 1/3/6/12/24h	
	Construction	plastic housing	
	Operation life (battery)	> 4 month	
	Data storage	16 MB, 3,200,000 measured values	
	LC-Display	size 90x64 mm	
	Weight	approx. 250g	
	Included in delivery	PC-Windows Software SmartGraph3 for graphical and numerical representation of measured values / instruction manual/ data cable / battery	
	Interface	USB, LAN	
	Power supply	4 x LR6 AA Mignon, USB, (POE opt.)	
	Max. operation temp.	-20...50°C	
	Max. rel. humidity	0...95% RH < 20g/m ³ (non condensing)	
	Max. altitude	10,000 m above sea level	
Temperature	Principle	NTC	
	Measurement range	-20... 50 °C	
	Accuracy	±0.3°C (0...40°C), otherwise 0.5°C	
	Resolution	0.1°C	
Rel. Humidity	Principle	capacitive	
	Measurement range	0...100% RH	
	Accuracy	±2% RH,	
	Resolution	0.1% RH,	
CO₂	Principle	NDIR	
	Measurement range	0... 5,000 ppm	
	Accuracy	± 50 ppm +3% of measured value (at 20 ° C and 1,013 mbar)	
	Resolution	1 ppm	
	Long-term stability	20 ppm/a	
Accessories	4 x LR6 AA Mignon		8120.SV1
	Power supply adapter		8120.NT



Lufft OPUS20E for External Sensors



Lufft OPUS20E for External Sensors		Order-No.
Lufft OPUS20E (neutral without Lufft-Logo 8120.30N)		8120.30
Lufft OPUS20E PoE (neutral without Lufft-Logo 8120.31N)		8120.31
Technical data	Dimensions	length 180mm, width 78mm, depth 32mm
	Measurement rate	10/30s, 1/10/12/15/30min, 1/3/6/12/24h
	Storage rate	1/10/12/15/30min, 1/3/6/12/24h
	Construction	plastic housing
	Operation life (battery)	> 1 Year
	Data storage	16 MB, 3,200,000 measured values
	LC-Display	size 90x64 mm
	Weight	approx. 250g
	Included in delivery	PC-Windows Software SmartGraph 3 for graphical and numerical representation of measured values / Instructions/ data cable/ battery/ WAGO connector / DIN rail bracket
	Interface	USB, LAN
	bus interface	RS 485
	Power supply	4 x LR6 AA Mignon, USB, (POE opt.)
	Max. operation temperature	-20...50°C
Input voltage 0-1V	Measurement range	0 ... 1V
	Accuracy	± 200µV ± 0.1% of measured value
	Resolution	< 500µV
Current measurement	Measurement range	2-wires: 4 ... 20mA, 3-wires: 0 ... 20mA
	Accuracy	± 4µA ± 0.1% of measured value
	Resolution	< 5µA
	Resistance	approx. 50 Ohm
Thermocouple K	Measurement range	-200°C ... 1200°C
	Accuracy	± 1°C ± 0.5% of measured value at -200°C ... 0°C ± 1°C ± 0.2% of measured value at 0°C ... 1200°C
	Resolution	< 0.2°C

With up to 10 external channels/sensors per OPUS20E.

The OPUS20E offers the highest flexibility and is excellent value for money. It allows the connection of up to 4 external temperature and relative humidity sensors, as well as 2 further analogue sensors. Intelligent BUS sensors can be integrated via the OPUS20E's RS485 interface (e.g. particle counter).

Air flow and differential pressure sensors are typically connected to the OPUS20E via analogue inputs as opposed to the maximum of 4 external temperature or humidity sensors that can be integrated via a digital BUS protocol.

In connection with its LAN capabilities, the OPUS20E is able to realize universal measurement networks in real time. For standard applications the SmartGraph 3 comes into play, and in order to fulfil the 21 CFR 11 guidelines the well-established and proven MCPS7 software is available.



Compatible sensors for OPUS20E		Page
Temperature/ Humidity	Digitale TFF20	24

Further compatible sensors on request.

Humidity:	Transducers with display
Flow:	Flow transmitters
Differential pressure:	Differential pressure transmitters
Particle:	Particle counters
CO ₂ :	CO ₂ transmitters

With up to 10 external sensors connectable per OPUS20E



Lufft OPUS20E Configurations Examples

Network with up to 200 channels

The OPUS20E is equipped with an analogue input that allows the connection of 2 sensors with voltage and current output, or rather PT100 temperature sensors in 3 and 4 wire technology.

At the same time up to 4 Lufft temperature/humidity sensors can be connected to the datalogger via a serial input.

Each fully equipped OPUS20E is a 10 channel datalogger that can record various data. It also allows data to be retrieved online and offline.

Lufft OPUS20E for External Sensors			Order-No.
Technical data			
Thermocouple J	Measurement range	-200°C ... 1,200°C	
	Accuracy	± 1°C ± 0.5% of measured value at -200°C ... 0°C ± 1°C ± 0.2% of measured value at 0°C ... 1,200°C	
	Resolution	< 0.2°C	
Thermocouple S	Measurement range	-50°C ... 1,700°C	
	Accuracy	± 1°C ± 0.5% of measured value at -50°C ... 0°C ± 1°C ± 0.2% of measured value at 0°C ... 1,700°C	
	Resolution	< 0.2°C	
PT100	Measurement range	-200°C ... 500°C	
	Accuracy	± 0.2°C ± 0.1% of measured value	
	Resolution	< 0.02°C	
Accessories	4 x LR6 AA Mignon		8120.SV1
	Power supply adapter		8120.NT
	Y Connector		8120.STY
	Extension and/or connecting cable for digital sensor, 2m		8120.KAB2
	Extension and/or connecting cable for digital sensor, 10m		8120.KAB10
	Extension and/or connecting cable for digital sensor, 25m		8120.KAB25
	Plug multipoint socket for analog sensortechnology access		8120.STE
	Temperature/ humidity sensor (see page 24)		8120.TFF
High-precision Temperature/Humidity Sensor (see page 26)		8130.TFF	

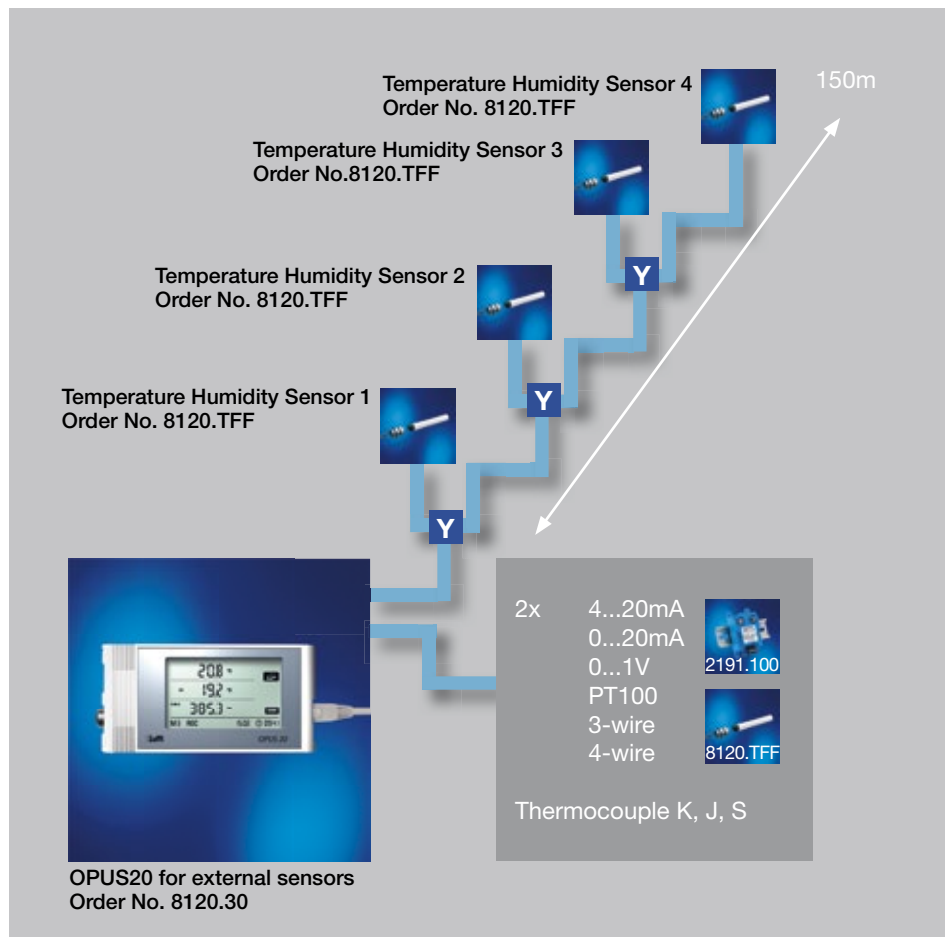

With up to 10 channels per datalogger transferring data in realtime.
Power supply via POE.

Comparison of SmartGraph3 / MCPS7 for Lufft OPUS 20-Series



Comparison of SmartGraph3 / MCPS7		SmartGraph3 (included in delivery)	MCPS7 (price on request)	Lufft I-Box
Configuration	Scanning network	■	■	■
	Management of OPUS devices in various projects		■	■
	Selection of sensors out of the sensor library	■		
	User-definable sensors	■	■	■
	Defining measurement and storage rates	■	■	
	Configuration of alarm limits	■	■	■
	Installation assistant			■
	Extensible and adaptable			■*
Data storage	Storage of data during online measurements	■	■	mit Logger-App
	Linking of individual files, saving of partial measurements		■	
	Automatic resumption of data recording after network failure or power cut		■	■
	Importing of non-recorded measured values after network failure		■	
Data transfer	Direct connection via USB online/offline	■		
	LAN-TCP/IP online and memory readout	■	■	■
	Incorporation of further systems e.g. particle counter		■	■*
	Data forwarding to e.g. control units or GLT		■	■*
Alarm	Colour changes in display		■	
	Alarm window (Pop-up)		■	
	Log entry of events (audit trail)		■	
	Alarm notification via SMS or e-mail		■	■
	Alarm actions (e.g. to switch on/off relays...)		■	■*
Exporting measured values	Manual	■	■	■
	Automatic during an online measurement		■	■
	Data transfer to remote databases			with database App
	Send Measurement Data via Email			with Mail-App
	Providing Measurement Data in JSON format			■
	Providing Measurement Data in CSV format			with CSV-App*
User administration (21CFR11)	Access controlled by password		■	■
	Password history		■	
	User groups		■	
	Audit trail		■	
	Electronic record, electronic signature		■	
Visualisation	Screen layouts freely definable		■	
	Y/T- diagramme		■	
	Trend, bar, digital and numerical representation	■	■	
	Calculation of statistical values (Min,Max,Med,Variance, Standard deviation)	■	■	■*
	Client-server operation		■	
	Process monitoring		■	
	Web server		■	■
Reporting	Reports with own logos		■	
	Reports in Excel pages		■	■
	Customer-specific evaluations over any number of time periods		■	
	Display live data in web browser			with 7digit-App*
Customer specific adaption	Support of customer specific measurement devices			■**
	Data transfer in customer specific systems			■**
Hardware and Housing	Din rail and cabinet mountable			■
	Headless operation (without monitor, keyboard, mouse)			■
	Power supply (power over ethernet or power supply unit)			■
	Designed for uninterrupted service and long-term usage			■
External climate data	Reference data acquisition from DWD (german official weather service)			with DWD-App*
	Reference data acquisition from Open Weather Map			with OWM-App*

* enabled with App from the Lufft I-BOX App-Store

** enabled with customer specific App

Looking for an „open solution“?
Do you want to realise your own special application with the measurement data?

Your Gateway for the Perfect Solution
to Your Problem:

Lufft I-BOX App-Store

Software modules:
ready-made or custom-built for you



The Lufft I-BOX Hardware



Lufft I-BOX		Order-No.
Lufft I-BOX		8200.00
Technical data	Dimensions	Length 105 mm, Width 75 mm, Depth 22mm
	Weight	approx. 140g
	Housing	Small plastic housing, integrated DIN rail mounting fixture
	Network	10/100BaseT, autosensing, autocrossing
	Connections	1 x network (RJ45) Screw terminals for power supply (alternative to PoE)
	LEDs / push buttons	System status via multi-color LED Current network speed and data transfer, manual device reset
	Power supply and power consumption	24 ... 48V DC (+ / -10%) via screw terminals, 60mA @ 24V // 40mA @ 48V
Temperature	Installed side-by-side: 0 ... 65°C, installed separately: 0 ... 70°C	
Humidity	0 ... 90% relative humidity, non-condensing	
Accessories	Plug-in power supply unit 8120.NT24	8120.NT24
	Power supply for DIN rail	8160.11084

With the Lufft I-Box, measuring instruments – such as the data logger OPUS20 – are easily integrated into corporate networks. The plug-and-play system provides standardized interrogation of live data from a variety of measuring instruments. This means that all data can be clearly displayed. In addition, the scope of supply includes an application for controlling alarms. The applications can be upgraded as required to suit individual needs. The Lufft I-BOX - the interface for industrial use.

- Easy commissioning
- Configuration and remote maintenance via browser interface
- User access protection
- Alarms by email
- Detailed help function
- Applications upgradeable as required
- 2 year warranty
- Increased interference immunity for the industrial environment
- Prepared for rail mounting
- Power consumption < 2.0 W
- Transmission of measured values to the corporate network
- Prepared for rail mounting

App The Lufft APP development is also becoming increasingly important for your business application.



More Information
Lufft I-BOX

www.lufft-i-box.com 37



Temperature logger with integrated USB-interface and automatic PDF-creation

Memory for 60,000 measurements, useable without software (default settings with 5 minutes interval), automatic PDF creation (no drivers required), optional software download), free adjustable recording interval 30 seconds up to 24 hours (via Software Log Connect), battery lifetime > 2 years (recording interval >15 minutes), status- and alarm-LEDs, includes wall mount.

Temperature PDF Datalogger			Order-No.
PDF Datalogger			8121.00
Technical data	Dimensions	100 x 19 x 19 mm	
	Weight	70 g	
	Measurement range	-40...+70°C	
	Accuracy	± 0.5°C (-10...40°C)	
	Power supply	1/2 AA size 3.6 Volt	
	Battery lifetime	> 3 years (time interval >15min)	



Temperature/Humidity logger with integrated USB interface and automatic PDF creation



Temperature/Humidity PDF Datalogger		Order-No.
PDF Datalogger		8122.00
Technical data	Dimensions	100 x 19 x 19 mm
	Weight	70 g
	Measurement range	-40...+70°C, 0...99% RH
	Resolution	0.1°C/0.1%
	Accuracy	± 0.5°C (-10...40°C) ± 3% (40...60% RH)
	Power supply	1/2 AA size 3.6 Volt
	Battery lifetime	> 2 years (time interval >15min)

Memory for 60,000 measurements, useable without software (default settings with 5 minutes interval), automatic PDF creation (no drivers required), optional software download, free adjustable recording interval 30 seconds up to 24 hours (via Software Log Connect), battery lifetime > 2 years (recording interval >15 minutes), status- and alarm-LEDs, includes wall mount.



When it comes to evaluation, have the works!
With the aid of powerful software, hand-held measuring devices are turning into archives.

Smart-Graph3

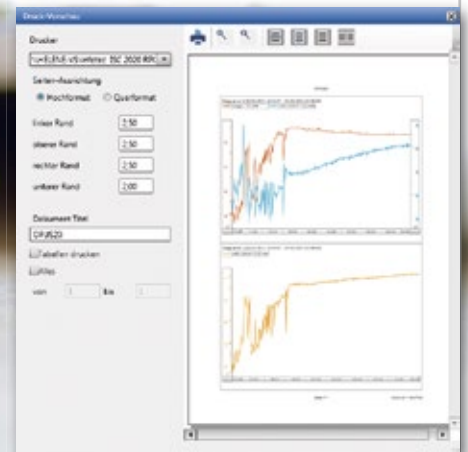
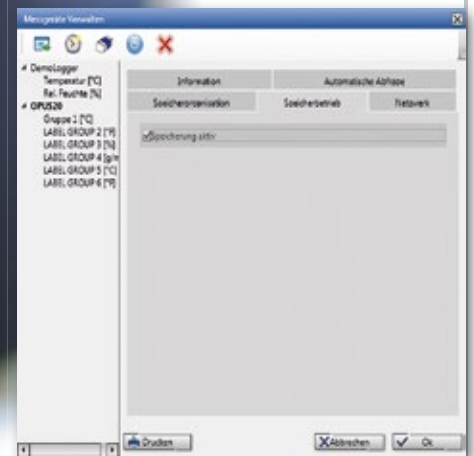

Software SmartGraph3 for Lufft Hand-held Devices and OPUS20-Series



Representation and Evaluation

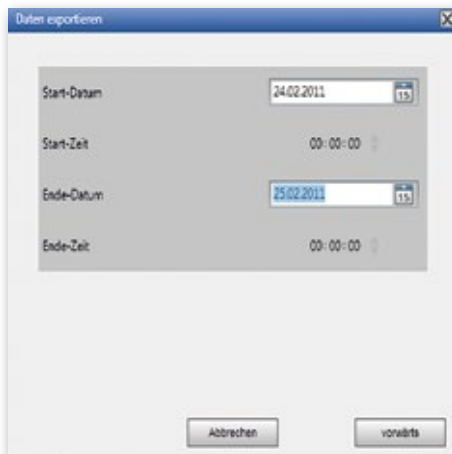

SmartGraph3 for OPUS20-Series

- An OPUS20 datalogger is automatically recognised and added as a “network device”.
- In addition to its data-readout function, the software possesses a recording mode that enables parallel recording to be displayed on the computer.
- The data from any desired number of OPUS20 devices can be read out simultaneously.
- The zoom function allows for quick analysis of critical time periods.
- The exporting of measured data in csv format enables it to be imported into Excel.
- The device configuration can be printed out in order to check installation parameters.
- Alarm limits – like the measured data – are chronologically managed at various times so that when changes in alarm limits occur, they can be retraced.
- Automatic data readout of all measured data is supported.

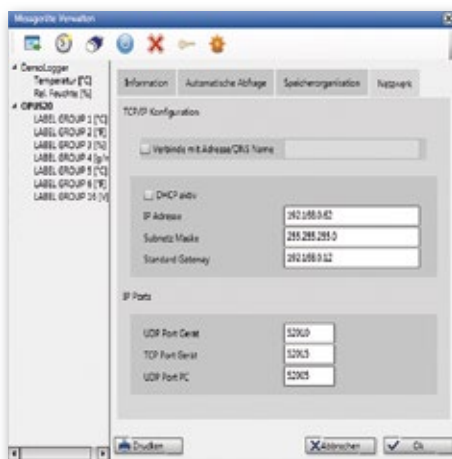

SmartGraph3 for Hand-held Measuring Devices

- A Lufft hand-held measuring device is automatically recognised and added by means of a USB interface.
- In addition to its data-readout function, the software possesses a recording mode that enables parallel recording to be displayed on the computer.
- The zoom function allows for quick analysis of critical time periods.
- The exporting of measured data in csv format enables it to be imported into Excel.
- Different measurement campaigns are archived in their respective accounts.
- All measurements recorded by the hand-held measuring device (also calculated values) are transferred to SmartGraph3.

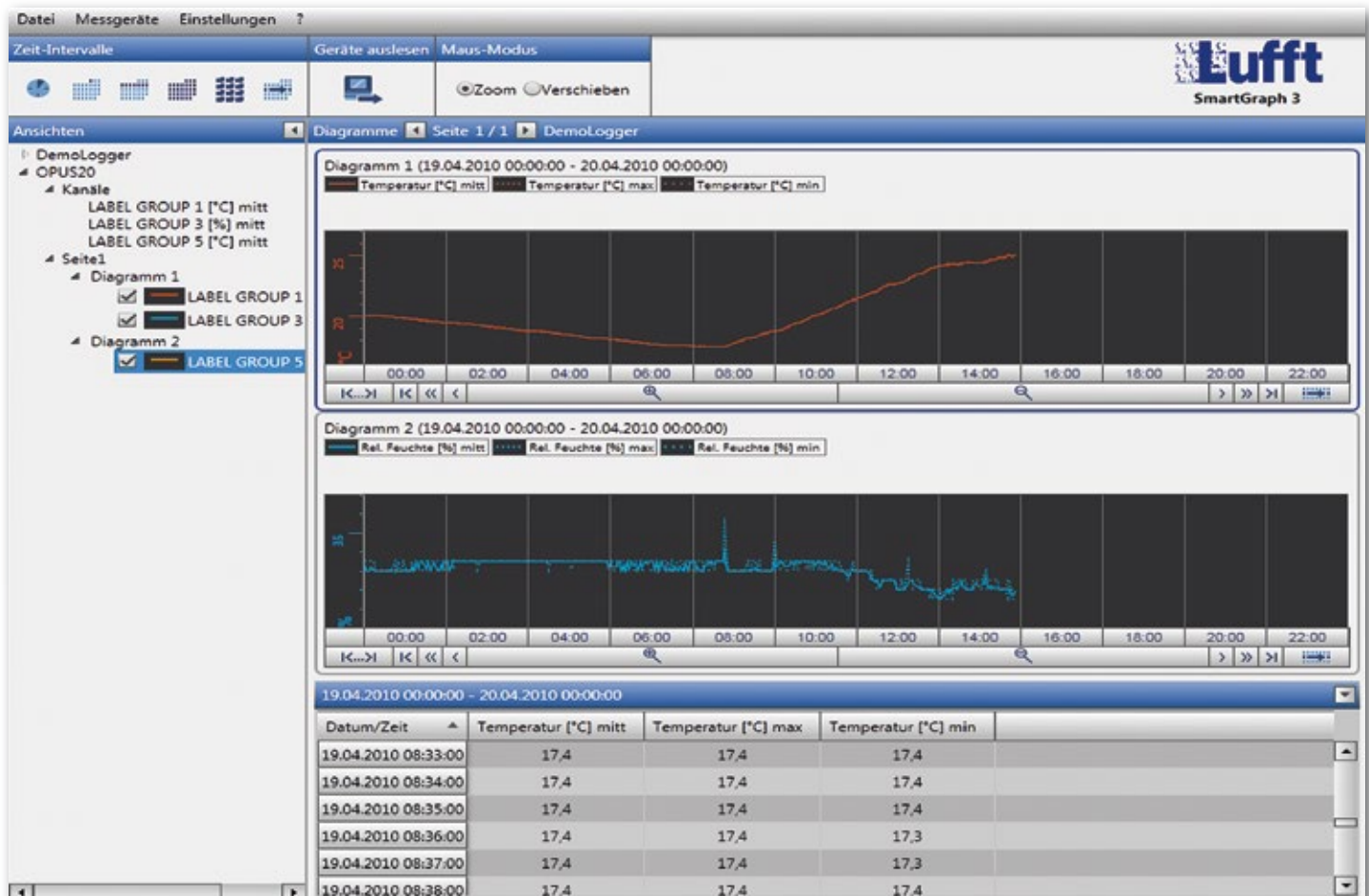



Software MCPS7 for Lufft OPUS20-Series

No place for coincidence. Anyone who records data in real time should not be satisfied with an "off the rack" solution only. Lufft has never done this and never will.

We have even put a lot of thought into the representation and evaluation of your measured data, and have developed special software that offers users numerous advantages and possibilities.

Data errors can be reduced to a minimum by means of clear processing and representation.

#	Gerät	Kanal	Einheit	Messstelle	Kommentar	Farbe	YMin	YMax	.*
1	OPUS20 - 1	Tc	°C		Temperatur	Blue	20	40	1
2	OPUS20 - 1	H_rel	%		rel. Luftfeuchte	Green	0	100	0
3	OPUS20 - 1	H_abs	g/m³		abs. Luftfeuchte	Red	0	100	0
4	OPUS20 - 1	DPc	°C		Taupunkt	Purple	0	20	1
5	OPUS20 - 1	U-Bat	V		Batteriespannung	Grey	0	10	1

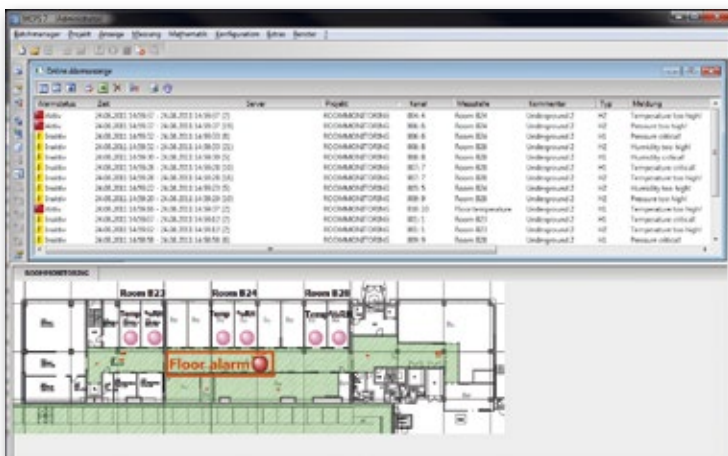
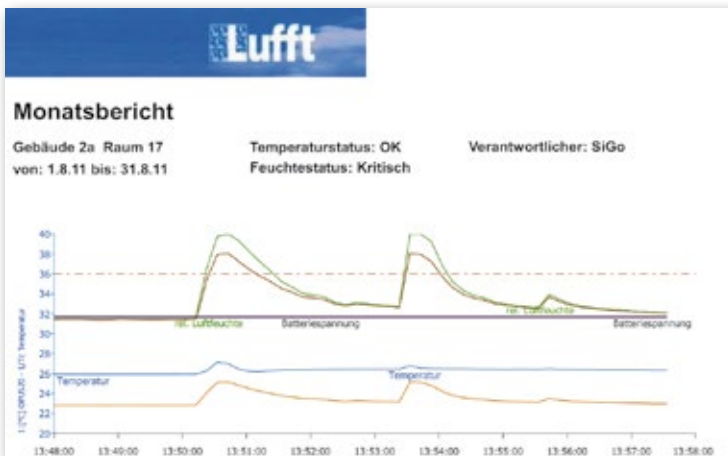

Software MCPS7 for Luftt OPUS20-Series

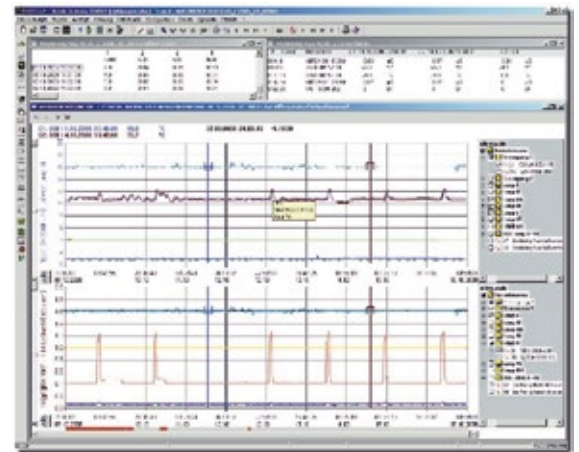
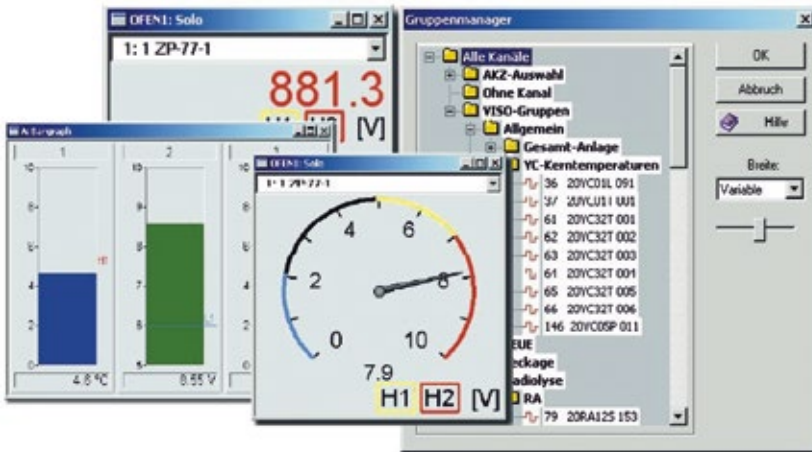

For Luftt the “User-Interface” is the icing on the cake, and for the user it’s the intuitive access to all functions.

Centralized Representation

Measurements are, to some extent, recorded every second: average values accumulate in the data logger, minimum and maximum values are observed, raw data is transferred to the central computer. Recording data in real time means that you have a large amount of data administration and at the same time have to arrange various measuring categories and points in a clear fashion. Some users are only interested in particular rooms, others want to have an overview of the particle sensors.

Consequently, a standard representation setup is simply insufficient. Instead of this, user-specific software is necessary such as MCPS7, which enables the

free configuration of graphic or numeric representation, or bar graphs; thus allowing you to incorporate and present comparable measuring categories in the same diagram.

In addition, MCPS7 has an integrated web server that visualises all the defined diagrams and places them in the intra-/extranet for other users. All you need is a password from the administrator.

Evaluation

The manual and automatic data export in the ASCII format offers the user additional advantages that exceed those of a standard display. There is also the possibility to define several formulae in MCPS7. In addition to this, daily, monthly and annual reports offer a simple overview of the

trends of the measured values. Furthermore, so-called MKT calculations supply special information – such as the median values of recorded temperature data (Mean Kinetic Temperature) – which is required in the pharmaceutical industry. Finally, in the audit trail of the MCPS7 package (21CFR compliant) all events are recorded: from system start and end, to user administration, changes to the device configuration, alarm messages plus confirmation text, the log-in and out of users, as well as sensor breakages and system crashes.

The software configuration of a sensor permits the flexible construction of a monitoring network design. The logger can incorporate many sensors; with configuration, the sensor is made acquainted with the flexible data acquisition module.

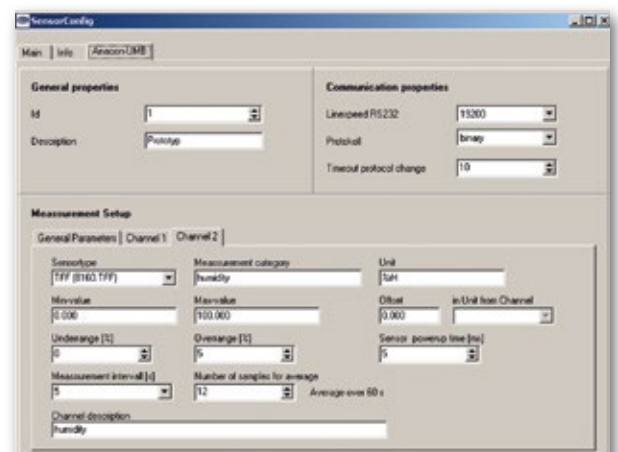

Competent
Qualifi-
cation and
Calibration

Competent

Qualification and Calibration

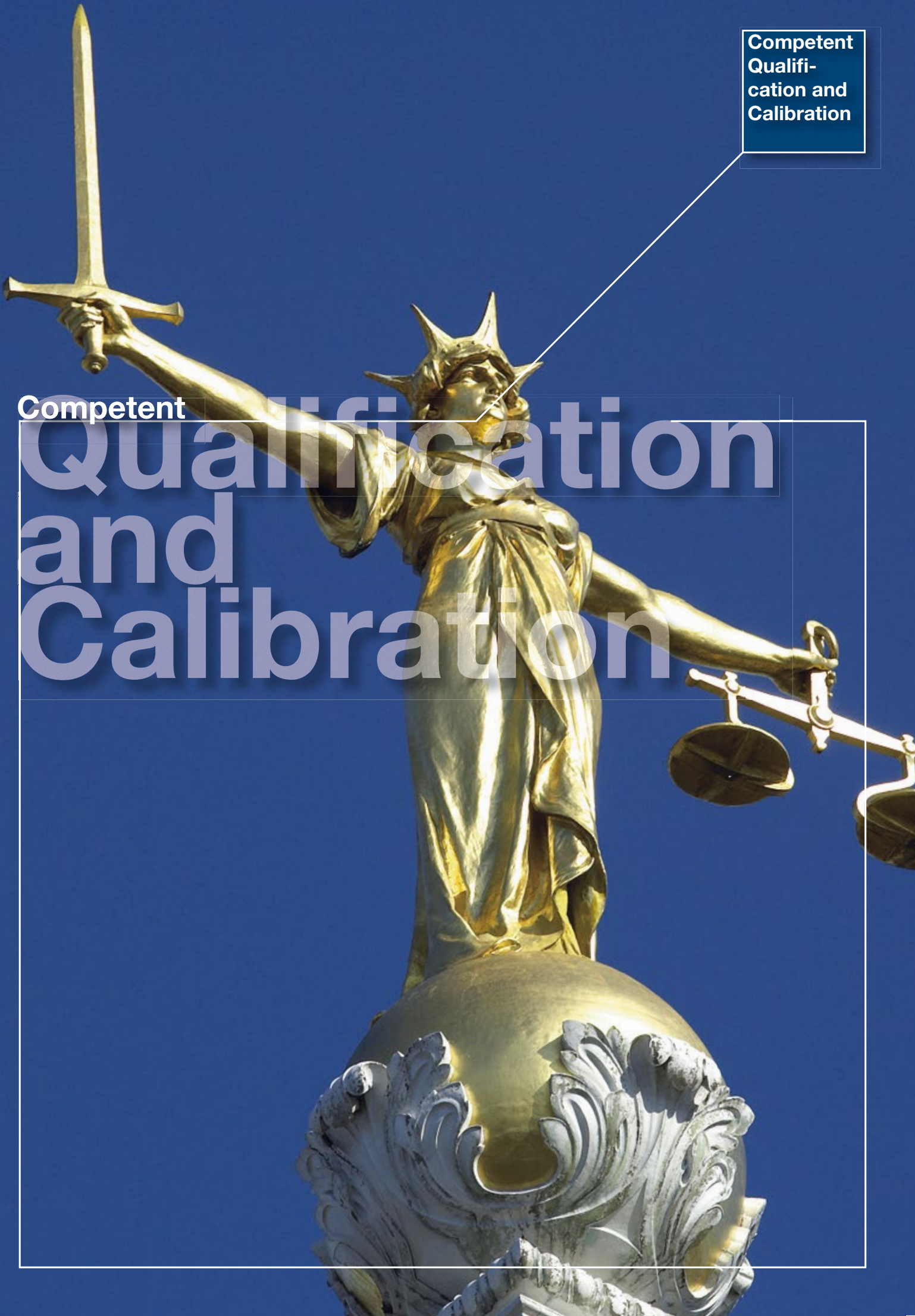



Qualification can only be done by qualified and experienced professionals. We ensure that you have excellent measuring technology experts at your side for such a task.

Imprecise measurements can have expensive repercussions. Therefore, Lufft products are tested according to the motto “To trust is good, to control is better”. Our products have to pass special tests that exceed that of conventional ones; firstly through a special type of qualification, both in production and at the customer, and secondly with the help of our DKD certified calibration, which ensures incorruptible results.

Qualification

A reliable monitoring system has to fulfil the highest requirements regarding preciseness and robustness. This is guaranteed by a test report that is provided by the manufacturer with each sensor. In addition to this, at Lufft the acquisition and analogue conversion of data is carried out in a special high resolution (16- or 32 bit technology), so that the preciseness of the sensors is retained.

A further quality feature is the local display that visualises measured values without losses due to rounding and with the same accuracy. At the same time identical measurement information is stored by central software in the archive. These quality requirements can be additionally tested during so-called “factory inspections” or audits of the customer’s production plant. Finally, there is an acceptance conducted in the plant and the highly sensitive goods are sent, sometimes travelling around half the globe.

A further “on-site qualification”, also known as the first calibration, is frequently conducted after the installation of the system. The requirements of “electronic records” (21 CFR 11) differentiates between the following types of qualification: Design Qualification (DQ), occurs during the requirement specification- and technical specification phase

- Installation Qualification (IQ), technical on-site acceptance such as an inspection of the wiring on the basis of the interface diagrams
- Operation Qualification (OQ), testing of the measurement chain from the sensor to the software, validation of the measurement chain, testing the accuracy of the sensor
- Performance Qualification (PQ), ensures the reliability during the products “life cycle”

Calibration

Imprecise measurements can have expensive economical repercussions, and for this reason a periodical adjustment of the sensors (justification), as well as a special comparison measurement (calibration) are of the utmost importance. During regular calibration a reference point measurements is compared with a reference standard, which normally has a much higher accuracy than the measurement under test. This round robin test is always a closed test, because these reference standards – whether directly or indirectly – have an accuracy that is based on and can be traced back to the official norm. In order to calibrate more than one

point, various conditions are generated on site according to customer requirements e.g. 3 different values for relative humidity. Such applications are indeed qualitative very sophisticated, and as such require specially trained personnel with profound experience in climatologic measurement technology; especially when dealing with the setup of comparison measurements regarding adjustment times.

The following applies to both qualification and calibration: there is a standard guideline, but no uniform procedure. Therefore, each user defines via the IQ/OQ his special requirements that have to be observed in both procedures respectively.

Incidentally, Lufft is also striving for the accreditation for an air flow measurement laboratory in the short-term future to add to its existing DKD laboratories for temperature, relative humidity and air pressure.

www.dkd-lab.info
www.dakks-lab.info

Experience in measurement technology since 1881
 Luftt DAKKS-certified according to DIN EN ISO/IEC 17025



Free Management of Certificates Online

www.dakks-lab.de



The triple point of water (balance of all 3 physical states solid, liquid and gas) is used to represent the International Temperature Scale and for the highest precision of temperature measurements in the milli-Kelvin range.

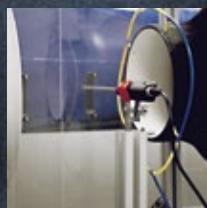
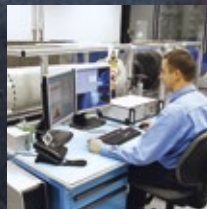
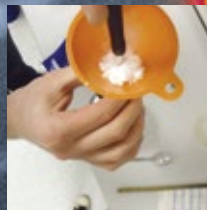
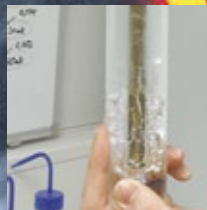

How reliable are your Measurements?

Even a state-of-the-art measuring instrument is still, strictly speaking, not one until it has obtained an internationally recognized calibration certificate. Only with its proven reliability can it meet its high demands. For this reason calibration technology, as well as production accuracy, has a deep-rooted tradition at Lufft. Since 1999 Lufft has been DKD-certified and DAkkS-certified since 2012.

Every sensor has to take a break once in a while. Each measuring unit fluctuates slightly during its operating time. This is not a question of a fault or a unit's functional efficiency, but a recognized phenomenon by all parties in this branch. A minimal fluctuation in precision occurs even with Lufft sensors; and our sensors are especially durable modules that are continually placed under extreme conditions (measuring CO₂ in incubators, humidity measurements in tropical conditions, e.g. at the equator).

Lufft, as a member of the Deutsche Kalibrierdienst (DKD), uses the prescribed reference norms from the Physikalisch-Technischen Bundesanstalt (PTB) for recalibration.

We offer an excellent service for each product:

Free comprehensive consultation that is tailor-made to suit your calibration needs, as well as free online management of certificates at www.dkd-lab.info / www.dakks-lab.info

E-mail to kalibrierung@lufft.de – and you can start managing your calibration certificates online straight away.

Content of our Service:

- Creation of certificates with new deliveries
- Calibrated leasing devices for the period of calibration
- Controlling of test materials over the entire lifetime



Absolute pressure

Calibration content:
700...1200 mbar
Pressure medium: air
(measurement uncertainty 0.15 mbar)



Temperature

Calibration content:
0.010°C at triple point of water (measurement uncertainty 5mK)
0.00°C at ice point (measurement uncertainty 10mK)
-40...+200°C in water bath (measurement uncertainty 15mK)
-40...+100°C in climate chamber (measurement uncertainty 100mK)

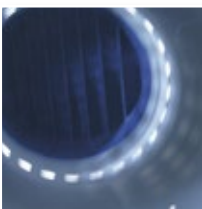

Airflow

Calibration content:
0.1...55m/s in wind tunnel
Airflow medium: air
(measurement uncertainty of 0.7% of measured value, at least 0.02m/s)



Relative humidity

Calibration content:
5...98% at 5...95°C (measurement uncertainty as of 0.2%)

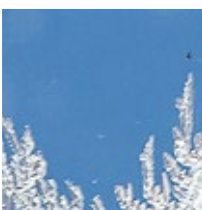

Dew point/ humidity generators

Calibration content:
-20...+95°C dew point temperature (measurement uncertainty of 80 mK)
5...98% at 5...95°C of humidity generator
(measurement uncertainty as of 0.2%)

www.dkd-lab.info
www.dakks-lab.info



Reference for Hand-Held Measuring Devices

MPA Stuttgart
Heel Baden-Baden
Tüv Arnstadt
Helmer Muhr am See
Matzner München
ESSKA.de Hamburg
ratio Tec Langenenslingen
Jahn Grub am Forst
AS-Wägetechnik Garching
T.A.S. Rostock
Stadtverwaltung Leonberg
Waller Eichstetten
HVF Weilheim
Weinbauinstitut Freiburg
Bosch Rexroth
VHB Holzbaubetriebe
Memmingen
GSG Geologie Würzburg
ESSKA.de Hamburg
Grünwälder Waagenteknik
Wuppertal
Honeywell Albstadt
Bauschutz Asperg
WSW Netz Wuppertal
Perfekter Halt Remscheid
MBE Menden
STRABAG Garching
Gebr.Hörner Schwäb.Gmünd
BS Beschichtung Greiz
Lau Hemer

Reference for OPUS20

Landratsamt Ravensburg
Veranstaltungs-u. Kongreß
Rosenheim
EADS Immenstaad
Phillips Böblingen
Hewlett Packard Böblingen
Festo Esslingen
Siemens Krefeld
BR Rigterink Bollberg
Femtosecond X-ray Hamburg
Long Life for Art Eichstetten
Siemens Krefeld
Diehlt BGT Defence Überlingen
Agilent Böblingen
Zumtobel Lighting Lemgo
Haupt Pharma Gronau
Universität Weimar
PTW Braunschweig
Eurocopter Donauwörth
Rehau Ingolstadt
PCI Augsburg
DLR Wesseling
ADC Lindau
Bosch Leonberg
Stadtbau Deggendorf
Biene&Natur Frensdorf
Airbus Hamburg
IFA Sankt Augustin
Trumpf Ditzingen
IBA Schwarzenbruck
Stadtarchiv WeilderStadt

a passion for precision · passion pour la précision · pasión

G. Lufft Mess-und
Regeltechnik GmbH

Address:
P.O. Box 4252
70719 Fellbach
Germany

Postal Address:
Gutenbergstrasse 20
70736 Fellbach
Germany

Tel: +49 711 51822-0
Fax: +49 711 51822-41

www.lufft.com
info@lufft.de



Subject to technical modifications · Lufft_Industry_10_2015

