

8115L

All Wheel Steer Loaders



**WACKER
NEUSON**
all it takes!



Productive and comfortable wheel loader for larger jobs

The 8115L all-wheel steer wheel loader offers the power and capacity for larger jobs, but has a compact design to access hard to reach areas. Three steering modes (four-wheel, two-wheel and crab steering) are electronically synched and provide maximum maneuverability in any operating environment. Load high sided trucks and bins with 11-feet, 11-inch hinge pin height.

- One-piece chassis and fixed center of gravity allow for constant payloads and increased stability
- Class-leading 100-hp engine delivers maximum power for lifting and hydraulic performance
- Diesel Oxidation Catalyst (DOC) with Selective Catalytic Reduction (SCR) aftertreatment means no diesel particulate filter, no regeneration, no maintenance
- Ergonomically designed cab layout includes pressurized cab, wide door for easy entry/exit, ample leg room with adjustable and telescoping steering wheel, HVAC with defrost, ergonomic joystick
- Standard hydraulic universal attachment plate provides greater versatility with ability to use nearly any attachment

8115L Technical specifications

Engine / Motor

Engine / Motor manufacturer	Deutz
Engine performance (standard)	100 hp
at rpm	2,300 rpm
Displacement	219 in ³

Weights

Operating weight	13,337 lb
Breakout force bucket	9,419 lbf
Payload (S=1.25)	6,393.34 lb
Tipping load (with bucket)	9,479.78 lb

Vehicle data

Bucket capacity (standard bucket)	1.5 yd ³
Speed (standard)	12.4 mph
Speed (optional)	24.8 mph
Standard tires	405/70-24
Differential lock	100% connectable

Hydraulic system

Operating hydraulics - operating pressure operating pressure	3,481 psi
Operating hydraulics - discharge capacity discharge capacity	22.2 US gpm

Filling capacities

Fuel tank capacity	31.7 US gal
Tank capacity hydraulic oil	16.9 US gal

8115L Dimensions

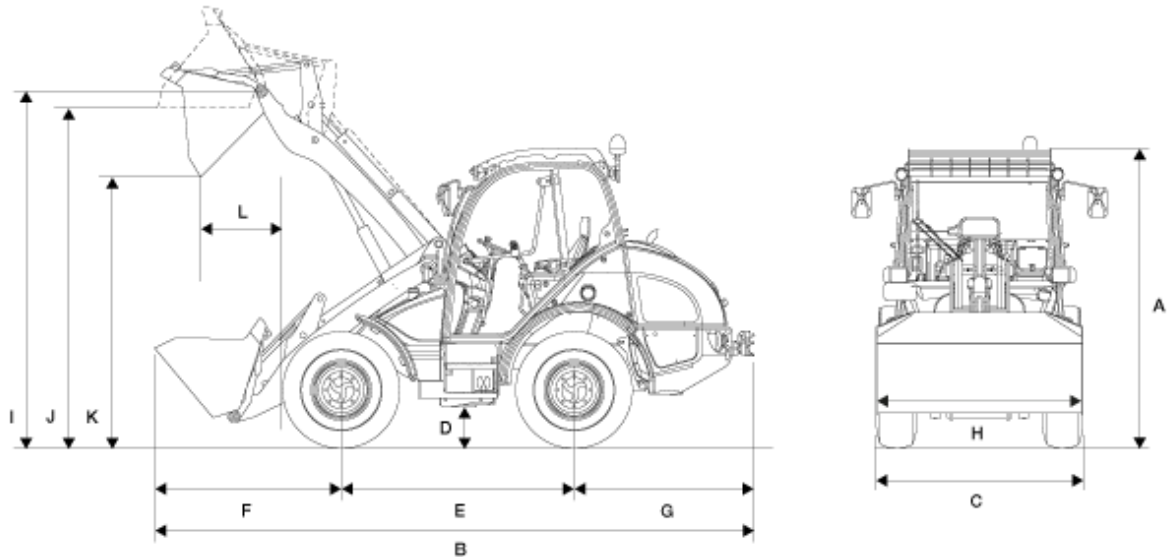

Dimensions

A	Height	105.51 in
B	Overall length	228.35 in
C	Overall width	77.56 in
D	Ground clearance	15.35 in
E	Wheelbase	84.65 in
F	Center of front axle to tip of teeth	79.92 in
G	Center of rear axle to end of vehicle	63.78 in
H	Bucket width	84.65 in
I	Hinge pin height	143.3 in
J	Overhead loading height	135 in
K	Dump height max.	116.9 in
	Stack height	125.98 in
	Inside turning radius (over tires)	116.14 in

Please note: that product availability can vary from country to country. It is possible that information / products may not be available in your country. More detailed information on engine power can be found in the operator's manual; the stated power may vary due to specific operating conditions. Subject to alterations and errors excepted. Applicable also to illustrations.

Copyright © 2020 Wacker Neuson SE.