

Bray *Tri Lok*[®]

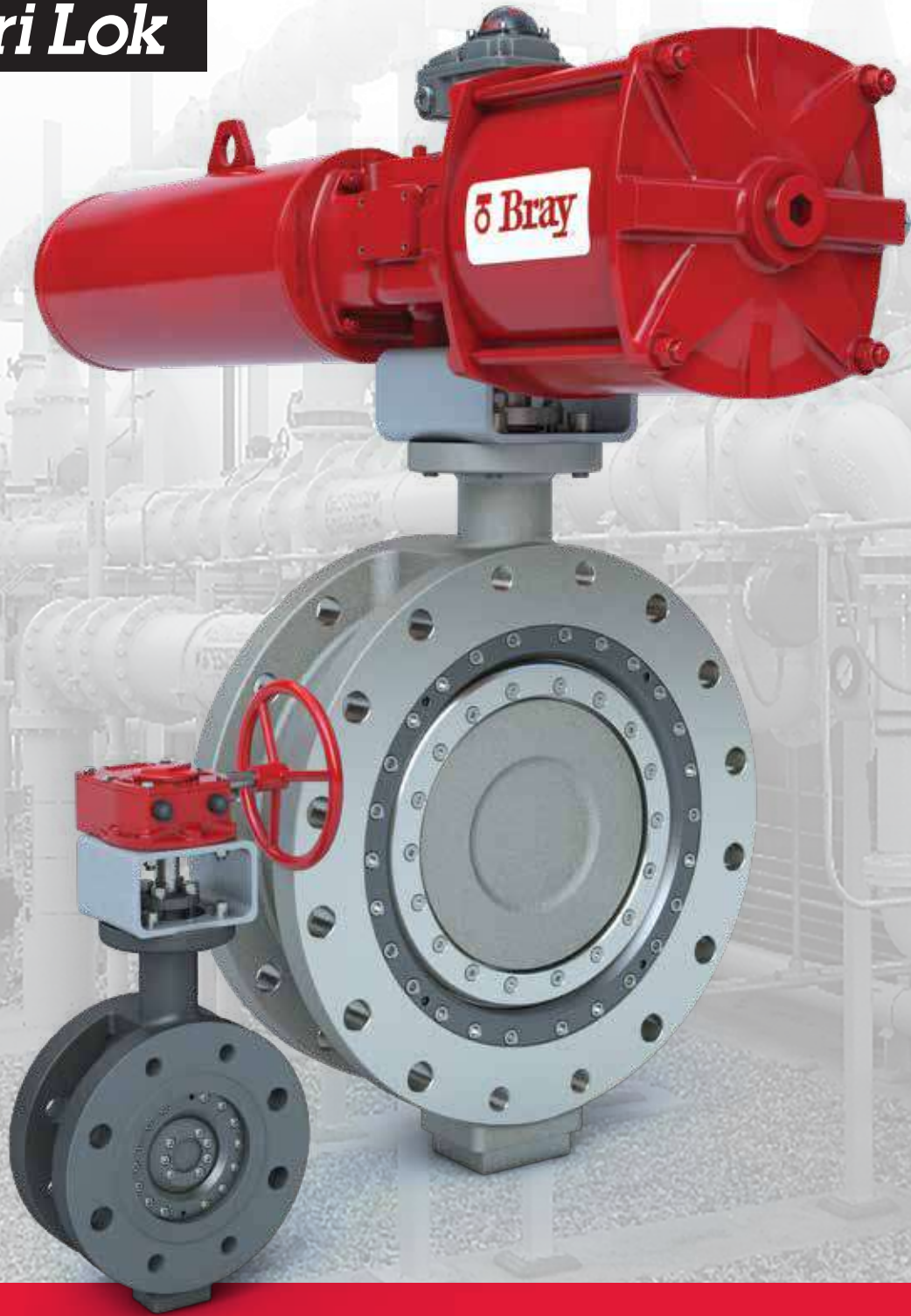

Bray[®]

BRAY.COM

THE HIGH PERFORMANCE COMPANY

1 SEAT

A fully field-replaceable seat extends the overall life of every Tri Lok valve, minimizing downtime and reducing the need for costly off-site repairs or total replacement. The hardened seat eliminates the risk of seat and seal galling, offering an extended lifespan and superior performance compared to Stellite.

2 SEAL RING

Flexible design and triple offset technology provide metal-to-metal sealing with zero leakage.

3 BEARINGS

Tri Lok standard bearing seals minimize ingress of media into the journal. Elongated stem bearings provide maximum support of the stem.

4 PACKING

The fully-adjustable, field-replaceable stem seal system (packing gland) is qualified to international fugitive emissions standards.

5 STEM

Tri Lok's unique splined disc-to-stem connection minimizes hysteresis, eliminates external connections and associated hardware, and allows for easy assembly/disassembly. Every Tri Lok valve features a one-piece stem with a blowout prevention ring located above the packing box, outside the pressure boundary, in accordance with international standards.

In accordance with API 609, every stem is indexed providing positive local indication of the disc position after installation in the piping system.

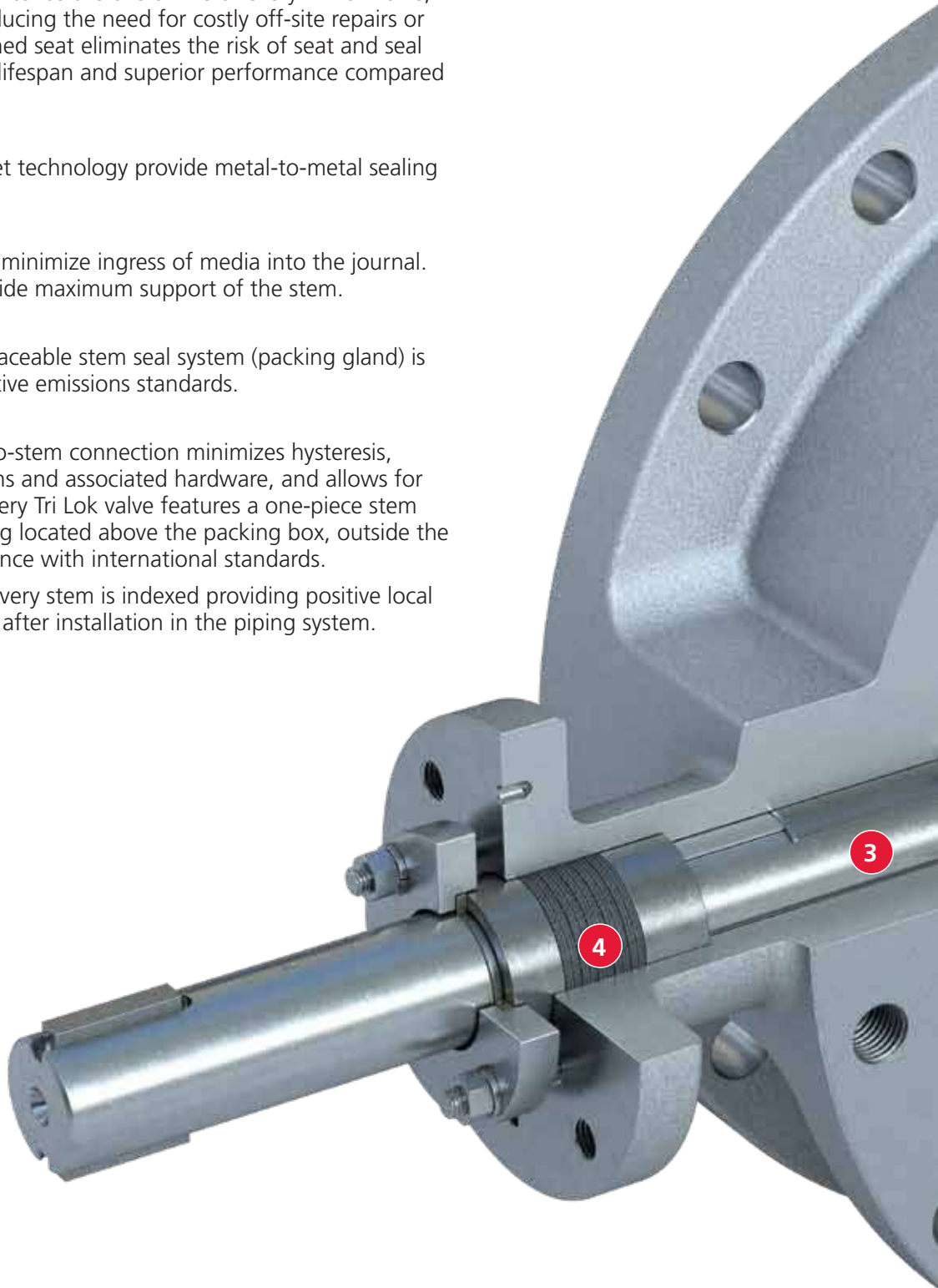

BODY STYLES

Wafer

Lug

Flanged

Long Pattern/Gate

ASME CLASS & SIZES

150 3" - 48"
(80mm - 1200mm)

300 3" - 48"
(80mm - 1200mm)

600 4" - 24"
(100mm - 600mm)

TEMPERATURE RANGE

-320°F to 842°F
(-196°C to 450°C)



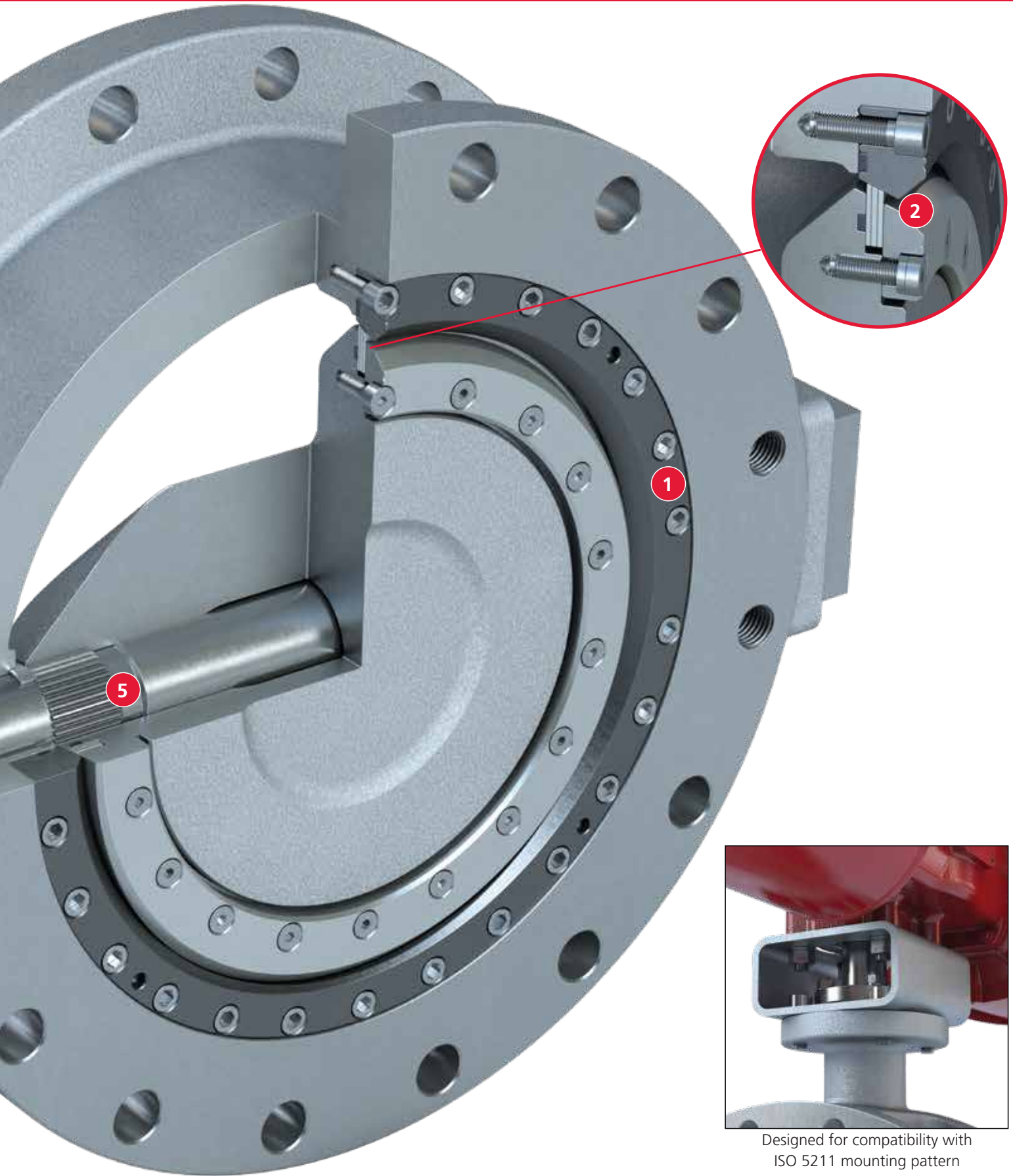

Designed for compatibility with ISO 5211 mounting pattern

FIELD REPLACEABLE SEAT/SEAL SYSTEM

Tri Lok valves feature a field-replaceable seat and seal ring, making it possible to exchange the seat and seal materials in the field without replacing the entire valve in the event of a change in service conditions. This extends the overall service life of the valve, substantially reducing maintenance, downtime and cost.

Tri Lok's non-rubbing metal-to-metal seal delivers zero leakage with a minimal amount of torque and is inherently fire-safe. The standard seal ring material is duplex stainless steel. The standard seat material is hardened stainless steel. The resilience of the seal ring ensures uniform peripheral sealing with the seat, achieving full shut-off regardless of flow direction.



SPLINED DISC/STEM CONNECTION

Tri Lok is the only valve in its class with a splined disc-to-stem connection, allowing for axial movement of the stem independent of the disc. This protects the disc/stem connection from temperature fluctuations and pressure effects, preventing the typical misalignment problems of rigidly attached discs and stems. Close tolerance engagement between the disc and stem also minimizes hysteresis.

Without external retention components, Tri Lok's internal disc-to-stem connection eliminates corrosion, vibration failure, and other issues associated with external connections, such as taper pins or keys.

Disassembling the Tri Lok disc-to-stem connection is as simple as sliding the shaft from the disc, unlike external connections that often require machining or grinding to remove.



TRIPLE OFFSET GEOMETRY

The first and second offset points of the stem are along the X (1) and Y (2) axes of the valve's centerline, which produces a cam like motion. The third offset (3) consists of an inclined conical profile machined into the valve sealing surface. This allows rotary engagement and disengagement of the seat and seal ring without interference, eliminating all rubbing between the seat and seal ring.

Once the seat and seal ring are fully engaged, torque is applied to create a bidirectional, zero-leak, metal-to-metal seal. For this reason, triple offset valves are often defined as "torque-seated", rather than "position-seated," as in the case of resilient or high performance butterfly valves.

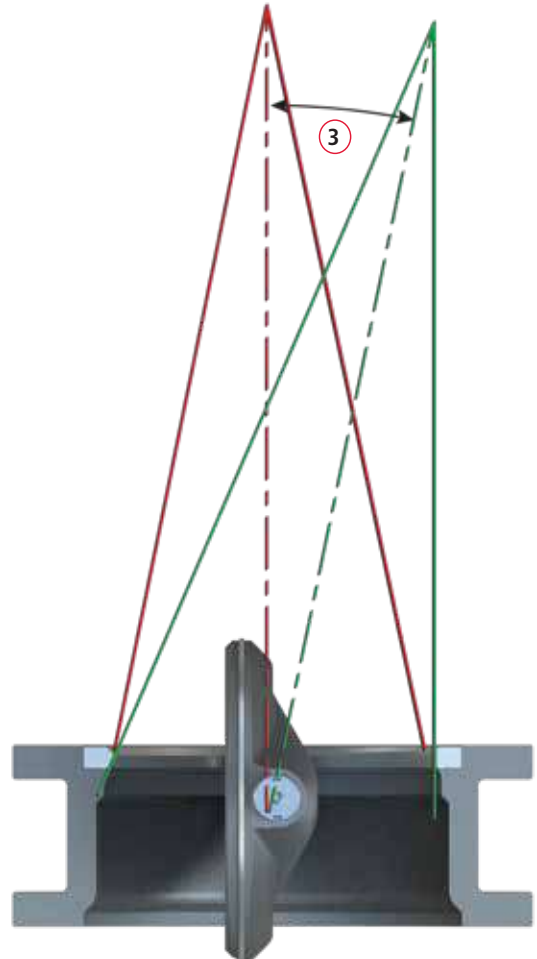
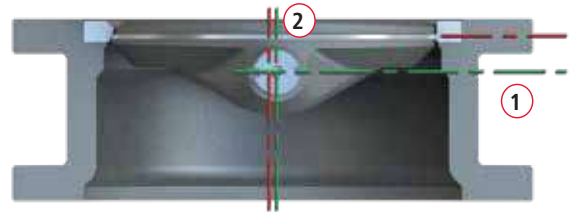

METAL-TO-METAL SEALING PRINCIPLE

- Torque Seated
- Non-Rubbing Thru Rotation
- Resilient Metal Seal Ring



No contact prior to seating



Contact only once seated

Tri Lok's geometry immediately disengages the entire seal ring from the seat upon opening rotation, which eliminates rubbing between sealing components.

DESIGN SPECIFICATIONS

Tri Lok Valves meet the following standards/specifications:

Valve Design & Pressure/Temperature Ratings	ASME B16.34
	ASME VIII
	API 609
	API 600
Fire Safe Certified	API 607
	ISO 10497
Low Fugitive Emission Certified	API 641
	ISO 15848-1
	TA LUFT
Actuator Mounting	ISO 5211
Face to Face Dimensions	API 609
	ASME B16.10
	ISO 5752
Seat Testing	API 598
	API 6D
	ISO 5208
	DIN 3230
	BS 6755
Flange Drilling	ASME B16.5
	ASME B16.47
	ISO 7005
Valve Markings	MSS-SP-25
	ASME B16.34
Manufacturing Quality	ISO 9001
	CE/PED

APPLICATIONS

Tri Lok is the premier isolation valve for operation in vacuum to high pressure service, particularly for applications requiring absolute zero leakage. The standard non-rubbing, non-jamming, metal-to-metal sealing system is fire-safe and the triple offset technology is specifically designed for zero leakage bi-directional shut-off.

Compared to gate, globe or ball valves of the same size and pressure class, Tri Lok provides space and weight savings while minimizing installation and maintenance costs. The long pattern body is designed as a one-to-one replacement for aging or leaking gate valves.

INSTALLATIONS IN A VARIETY OF APPLICATIONS

- Cryogenic Services
- Bulk Liquid Storage
- Steam Distribution Systems
- Power Generation
- Geothermal Steam
- Sugar and Ethanol Production
- Carbon Black Processing
- Pulp and Paper Liquor Processing
- Chemical Refineries
- Water & Wastewater Treatment
- Upstream Oil and Gas Processing
- Shipbuilding



MATERIALS OF CONSTRUCTION

Bray stocks commonly used material trims to fulfill applications across many industries with short lead times, as shown in the table below. The disc material is commonly the same material as the body to allow full pressure/temperature rating, maintain uniform thermal expansion at elevated temperatures, and facilitate the disc's primary function of "carrying" the seal ring. Seat, seal ring and remaining trim are selected to meet the required mechanical properties while providing sufficient corrosion resistance. Custom engineered configurations are also available in nickel aluminum bronze, duplex stainless steel, Inconel®, Monel, and titanium.

COMPONENT	MATERIAL
Body	Carbon Steel Stainless Steel
Disc	Carbon Steel Stainless Steel
Stem	410 Stainless Steel 17-4PH XM-19 (Nitronic®)
Body Seat	316SS Hardened
Disc Seal	Laminated 318 Stainless Steel/Graphite

Nitronic® is a registered trademark of Armco Inc.
Inconel® is a registered trademark of Inco Alloys International, Inc.



20" ASME 150
Long Pattern/Gate Body
B16.10 face-to-face
Carbon Steel with NACE trim



THE HIGH PERFORMANCE COMPANY



BRAY INTERNATIONAL PRIMARY SALES AND SERVICE LOCATIONS

USA
Houston, Texas

AFRICA
Johannesburg

BENELUX
Heerhugowaard

BRAZIL
Paulinia, Sao Paulo

CANADA
Montreal

CHILE
Santiago

CHINA
Hangzhou, Zhejiang

COLOMBIA
Bogotá

FRANCE
Voiron

GERMANY
Krefeld

INDIA
Vadodara

ITALY
Milano

MEXICO
Zapopan, Jalisco

MIDDLE EAST
Dubai

PACIFIC
Melbourne, Australia

PERU
Lima

POLAND
Oświęcim

RUSSIA
Moscow

SINGAPORE
Ubi Techpark

SOUTH KOREA
Seoul

SOUTHEAST ASIA
Malaysia

UNITED KINGDOM
Glasgow

FLOW-TEK

USA
Houston, Texas

BRAZIL
Paulinia, Sao Paulo

CHINA
Hangzhou, Zhejiang

RITE CORPORATION

CANADA
Montreal

VALVTRONIC

ARGENTINA
Buenos Aires

AMRESIST

USA
Houston, Texas

KUGELHAHN MÜLLER

GERMANY
Krefeld

HEADQUARTERS

Bray International, Inc.

13333 Westland East Blvd.

Houston, Texas 77041

Tel: 281.894.5454

bray.com

All statements, technical information, and recommendations in this bulletin are for general use only. Consult Bray representatives or factory for the specific requirements and material selection for your intended application. The right to change or modify product design or product without prior notice is reserved. Patents issued and applied for worldwide.

Tri Lok® is a registered trademark of Bray International, Inc.

Bray® is a registered trademark of Bray International, Inc.

© 2018 Bray International. All rights reserved.

B-1039_EL_TriLok_10_4_2018