

Versatec 500

Water Source/Geothermal Heat Pump

0.75 - 6 Ton



Formerly known as Envision² Compact



Water-Furnace[®]
Commercial Solutions

VERSATEC 500

Versatec 500 products offer the industry-leading efficiencies of full-size units in a much smaller footprint. The compact cabinet makes this heat pump system the perfect solution for commercial retrofit and boiler/tower applications. Available in a wide selection of capacities (009-072), the Versatec 500 carries many of our most advanced features—including the Aurora generation of controls. Options include a factory-installed 24V motorized on/off water valve option for VFD pumping with automatic internal water flow control; hot gas bypass and reheat; and high-efficiency PSC, 5-Speed ECM, or variable speed ECM motors to fit your efficiency and comfort needs. Versatec 500 units are more than twice as efficient as the ASHRAE 90.1 standard and utilize environmentally friendly R410A refrigerant.

Industry-leading efficiencies in a small footprint for unmatched flexibility in geothermal and boiler/tower installations.



KEY FEATURES

COMPRESSOR: Copeland K-5 Scroll™ or LG rotary (single speed) and Copeland Scroll UltraTech™ (dual capacity) in commercial voltages mounted on a double isolation system.

WATER LINES: Copper FPT waterline connections, securely mounted flush to cabinet corner post.

COAXIAL HEAT EXCHANGER: Oversized and convoluted with copper inner tube (optional cupronickel) and steel outer tube, designed for maximum heat transfer at normal and low water flow rates to minimize pressure drop.

ALUMINUM AIR COIL: An aluminum air coil is featured in all Versatec 500 units to provide exceptional durability and high efficiencies. Added protection is also available with an optional AlumiSeal™ coating.

CABINET: The cabinets utilize a compact form and are constructed of heavy gauge environmentally responsible galvanized steel for maximum corrosion resistance. Units are available with a durable white powder coat finish or unpainted. All interior surfaces are lined with 1/2" thick, foil lined acoustic type fiber insulation, applied in a manner that prevents the introduction of glass fibers into the air stream. Multiple knockouts in various sizes facilitate power and low voltage wiring.

REFRIGERANT CIRCUIT: Units utilize R410A refrigerant in sealed circuits. Metering accomplished with a bi-flow thermostatic expansion valve to deliver optimum flow over a wide range of conditions without troublesome check valves. Four-way solenoid activated reversing valve defaults to heating and is "cool brazed" at the factory.

FILTER RACK/RAIL: Redesigned filter rack includes a standard 1" filter rail with a MERV 4 filter. Options include a 1" or 2" four-sided filter rack suitable for ducted applications, or a 2" filter rail with MERV 13 filters for non-ducted applications.

CONTROLS: Aurora Base Control is standard. Optional Universal Protocol Converter featuring N2, LonWorks, and BACnet compatibility.

BLOWER MOTOR: PSC blower motors provide high efficiency while allowing quiet operation and wide range of airflow selections. Optional 5-Speed ECM and variable speed ECM blower motors are available for improved efficiency and comfort.

FLOW REGULATOR: Optional factory installed internal water flow regulator.

WATER VALVE: Optional factory installed internal 24V on/off 2-way water valve for VFD pumping applications.

HOT WATER GENERATOR: Optional factory installed heat exchanger with field mounted external pump.

ADDITIONAL OPTIONS:

- Hot Gas Reheat & Bypass (015-072)
- 460V models with X-13 motor option do not require the additional neutral wire
- Sound kits for Quiet Operation
- Factory installed disconnect, Phase Guard and IntelliStart soft start
- Composite or Stainless Steel drain pans with Secondary drain connections
- Extended range coaxial heat exchanger and piping insulation

VERSATEC 500 | VERTICAL 0.75 - 6 TON



Model	A	B	C
009 - 012	22.5	22.2	30.2
015 - 018	22.5	26.2	40.2
024 - 030	22.5	26.2	44.2
036 - 038	25.5	31.2	44.2
042 - 049	25.5	31.2	48.2
060 - 072	25.5	31.2	52.2

More than twice as efficient as the ASHRAE 90.1 standard

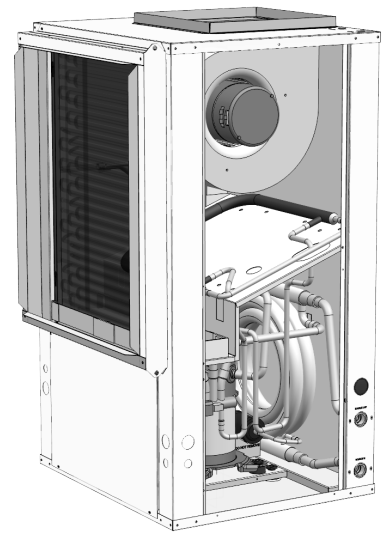

VERSATEC 500 | HORIZONTAL 0.75 - 6 TON

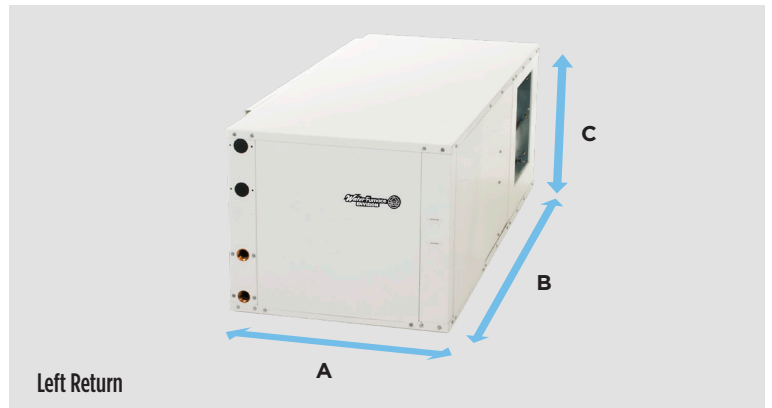
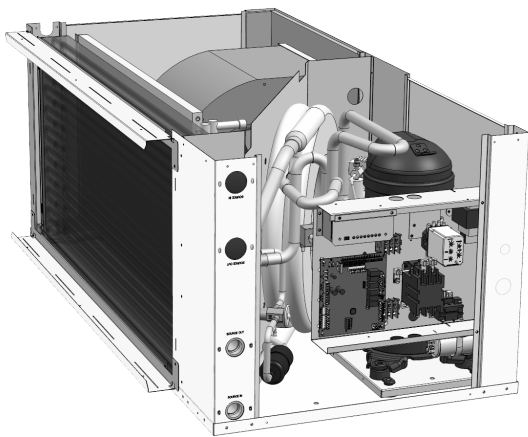

Model	A	B	C
009 - 012	22.5	35.0	17.2
015 - 018	22.5	42.0	19.2
024 - 030	22.5	45.0	19.2
036 - 038	22.5	48.0	21.2
042 - 049	25.5	53.0	21.2
060-064	25.5	61.0	21.2
070-072	25.5	68.0	21.2

AHRI/ISO 13256-1 PERFORMANCE RATINGS

PSC Motors

AHRI/ASHRAE/ISO 13256-1
English (IP) Units

Model	Capacity Modulation	Flow Rate		Water Loop Heat Pump				Ground Water Heat Pump				Ground Loop Heat Pump			
				Cooling EWT 86°F		Heating EWT 68°F		Cooling EWT 59°F		Heating EWT 50°F		Cooling Brine Full Load 77°F Part Load 68°F		Heating Brine Full Load 32°F Part Load 41°F	
		gpm	cfm	Capacity Btuh	EER Btuh/W	Capacity Btuh	COP	Capacity Btuh	EER Btuh/W	Capacity Btuh	COP	Capacity Btuh	EER Btuh/W	Capacity Btuh	COP
009	Single	3.0	350	9,600	14.0	11,600	5.2	10,800	22.2	10,600	4.4	9,800	16.7	7,800	3.4
012	Single	3.5	400	11,300	14.0	14,800	5.0	13,200	23.1	12,000	4.2	12,000	16.5	9,500	3.5
015	Single	4.0	500	14,400	15.9	18,500	5.1	16,700	26.0	15,500	4.5	15,000	18.0	12,000	3.8
018	Single	5.0	600	17,400	14.8	23,000	5.1	20,600	24.7	18,700	4.3	18,500	17.3	14,500	3.5
024	Single	8.0	850	24,800	16.2	29,600	5.0	28,100	24.0	23,900	4.3	26,000	19.2	18,900	3.7
030	Single	8.0	900	26,800	17.9	32,900	5.3	30,800	27.1	26,000	4.7	27,900	21.1	20,300	3.7
036	Single	9.0	1200	31,500	14.8	40,200	5.3	35,100	24.4	29,200	4.5	32,900	19.2	24,400	3.8
042	Single	11.0	1300	38,300	15.4	45,600	5.2	42,300	23.3	36,000	4.3	40,300	18.5	28,900	3.5
048	Single	12.0	1500	43,200	13.3	55,600	4.9	48,900	22.3	44,700	4.2	45,500	16.0	36,400	3.7
060	Single	15.0	1800	61,000	15.2	74,100	5.2	66,600	22.8	57,300	4.4	62,300	17.4	46,100	3.7
070	Single	18.0	2000	66,200	14.4	85,000	4.6	73,500	20.8	67,100	4.0	69,100	16.6	53,500	3.4

Cooling capacities based upon 80.6°F DB, 66.2°F WB entering air temperature
Heating capacities based upon 68°F DB, 59°F WB entering air temperature
All ratings based upon 208V operation

7/27/18

ECM & X13 Motors

AHRI/ASHRAE/ISO 13256-1
English (IP) Units

Model	Capacity Modulation	Flow Rate		Water Loop Heat Pump				Ground Water Heat Pump				Ground Loop Heat Pump			
				Cooling EWT 86°F		Heating EWT 68°F		Cooling EWT 59°F		Heating EWT 50°F		Cooling Brine Full Load 77°F Part Load 68°F		Heating Brine Full Load 32°F Part Load 41°F	
		gpm	cfm	Capacity Btuh	EER Btu-h/W	Capacity Btuh	COP	Capacity Btuh	EER Btu-h/W	Capacity Btuh	COP	Capacity Btuh	EER Btu-h/W	Capacity Btuh	COP
009	Single	3.0	350	9,600	14.6	11,700	5.3	11,000	23.0	10,700	4.5	9,800	17.1	7,800	3.6
012	Single	3.5	400	11,400	14.4	14,900	5.2	13,400	23.5	12,400	4.3	12,200	17.1	9,500	3.6
015	Single	4.0	500	14,400	16.5	18,500	5.3	16,700	27.0	15,500	4.7	15,000	18.8	12,000	4.0
018	Single	5.0	600	17,400	15.7	23,000	5.3	20,600	26.0	18,700	4.6	18,500	18.3	14,500	3.8
024	Single	8.0	800	24,800	17.0	29,600	5.3	28,100	27.5	23,900	4.6	26,000	19.6	18,900	3.8
030	Single	8.0	900	27,000	18.9	32,900	5.6	31,200	29.5	26,000	4.8	28,100	22.0	20,500	3.9
036	Single	9.0	1200	32,300	18.8	36,500	5.7	36,800	28.8	29,200	4.9	33,700	22.0	24,400	4.2
042	Single	11.0	1300	39,000	18.6	45,600	5.8	43,900	28.1	36,100	4.9	40,700	21.7	28,900	4.0
048	Single	12.0	1500	44,100	16.3	55,600	5.4	50,300	25.9	44,700	4.7	45,900	18.8	36,400	4.0
060	Single	15.0	1800	61,100	16.4	74,100	5.5	66,900	24.3	59,200	4.7	62,200	18.4	47,900	4.0
070	Single	18.0	2000	66,200	15.3	85,000	5.0	75,000	22.9	68,000	4.4	69,100	17.6	54,000	3.7
026	Full	8.0	950	24,900	16.8	30,100	5.5	27,700	24.0	23,900	4.8	26,400	19.6	19,500	4.0
	Part	7.0	750	18,900	18.6	22,000	6.1	22,200	29.7	17,500	4.9	21,000	26.0	16,400	4.5
038	Full	9.0	1300	36,500	17.0	43,300	5.5	40,000	24.4	35,000	4.9	38,200	19.7	28,500	4.2
	Part	8.0	1150	26,500	19.0	31,300	6.4	29,900	32.1	24,900	5.1	29,500	28.0	22,900	4.8
049	Full	12.0	1600	49,100	17.2	59,000	5.5	54,100	24.5	47,200	4.6	50,800	19.3	38,200	4.0
	Part	11.0	1400	36,300	19.1	41,700	6.1	41,600	33.0	33,600	4.7	39,800	27.4	31,000	4.4
064	Full	16.0	1800	62,300	16.4	73,900	5.2	69,000	23.9	60,400	4.6	65,500	19.3	47,300	3.8
	Part	14.0	1500	45,800	18.1	53,200	5.9	53,000	30.7	43,500	4.8	50,500	26.5	38,200	4.3
072	Full	18.0	2000	70,100	15.6	88,000	4.8	79,000	22.0	71,000	4.3	73,800	18.2	55,400	3.7
	Part	16.0	1500	54,200	17.0	66,000	5.1	61,500	27.6	52,700	4.3	59,400	24.9	47,400	3.9

Cooling capacities based upon 80.6°F DB, 66.2°F WB entering air temperature
Heating capacities based upon 68°F DB, 59°F WB entering air temperature
All ratings based upon 208V operation

7/27/18



BR1022AN 1/22

visit us at waterfurnace.com