

Versatec 300

Water Source/Geothermal Heat Pump Console

0.75 - 1.5 Ton



Formerly known as Envision Consoles Low Sill (LC)

WaterFurnace
Commercial Solutions

Versatec 300 SERIES LOW SILL CONSOLES

Perfect for classrooms, offices, hotels, or any room without ductwork, the Versatec 300 Series Console delivers cutting edge heating and cooling technology. A single speed R-410A rotary compressor is the heart of the console, which is available in a variety of cabinet and piping configurations. It features the ability to operate across a wide range of loop temperatures and its footprint is designed to match “legacy” consoles for easy retrofitting.

Over the last 30 years, WaterFurnace has built its reputation on innovation, quality, and customer satisfaction. We're committed to providing the highest quality products and the most extensive support network in the industry. By specifying WaterFurnace 0.75 - 1.5 ton Versatec 300 Series Low Sill Consoles, you can rest assured your customers are investing in a product with superior quality and performance.

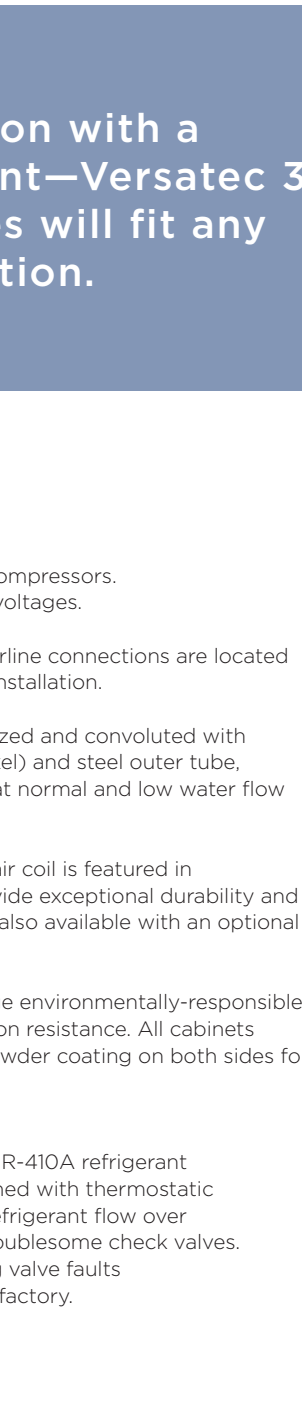

Efficient operation with a compact footprint—Versatec 300 Low Sill Consoles will fit any ductless application.

KEY FEATURES

COMPRESSOR: Single speed rotary compressors. Available in commercial single phase voltages.

WATER LINES: 1/2" Copper FPT waterline connections are located on the end of the chassis for ease of installation.

COAXIAL HEAT EXCHANGER: Oversized and convoluted with copper inner tube (optional cupronickel) and steel outer tube, designed for maximum heat transfer at normal and low water flow rates to minimize pressure drop.

ALUMINUM AIR COIL: An aluminum air coil is featured in all Versatec 300 Console units to provide exceptional durability and high efficiencies. Added protection is also available with an optional AlumiSeal™ coating.

CABINET: Constructed of heavy gauge environmentally-responsible galvanized steel for maximum corrosion resistance. All cabinets finished with beige textured epoxy powder coating on both sides for added protection. Fits “legacy” console footprints.

REFRIGERANT CIRCUIT: Units utilize R-410A refrigerant in sealed circuits. Metering accomplished with thermostatic expansion valve to deliver optimum refrigerant flow over a wide range of conditions without troublesome check valves. Four-way solenoid activated reversing valve faults to heating and is “cool brazed” at the factory.

CONTROLS: The Compressor Control Module (CCM) comes standard and provides a more reliable alternative to electro-mechanical systems. The full featured Aurora Microprocessor Control with expanded unit sensors is also available as an option. The optional Aurora UPC Control adds N2, LON & BACnet compatibility along with unit or wall mounted sensors or wall mounted thermostat options.

FAN MOTOR: All units come with a high efficiency 3 speed ECM fan motor.

ELECTRICAL DISCONNECTS: Optional, field installed fused or non-fused electrical disconnect available. Fused sizes available in 10, 12, 15, 20 and 25 amp fuses.

ADDITIONAL OPTIONS:

- EXTENDED RANGE COAXIAL HEAT EXCHANGER AND PIPING INSULATION
- CABINETS AVAILABLE IN FLAT OR SLOPE TOP WITH AN EXTENDED CABINET OPTION
- LEFT OR RIGHT CONTROLS
- STAINLESS STEEL CONDENSATE DRAIN PAN WITH INTERNALLY TRAPPED DRAIN LINE

VERSATEC 300 | 0.75 - 1.5 TON

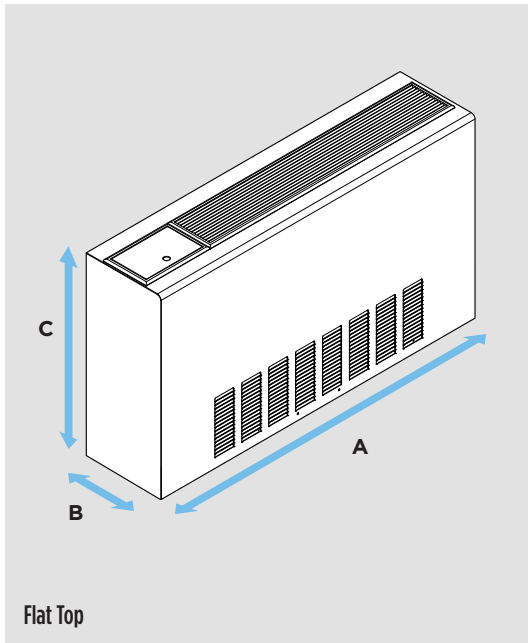

Model	A	B	C
009 - 012	45.0"	10.8"	22.5"
015 - 018	50.0"	12.8"	22.5"

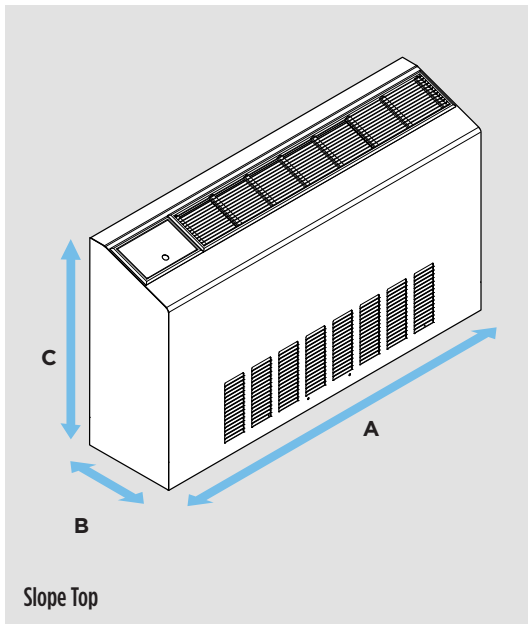

Model	A	B	C
009 - 012	45.0"	10.8"	24.0"
015 - 018	50.0"	12.8"	24.0"

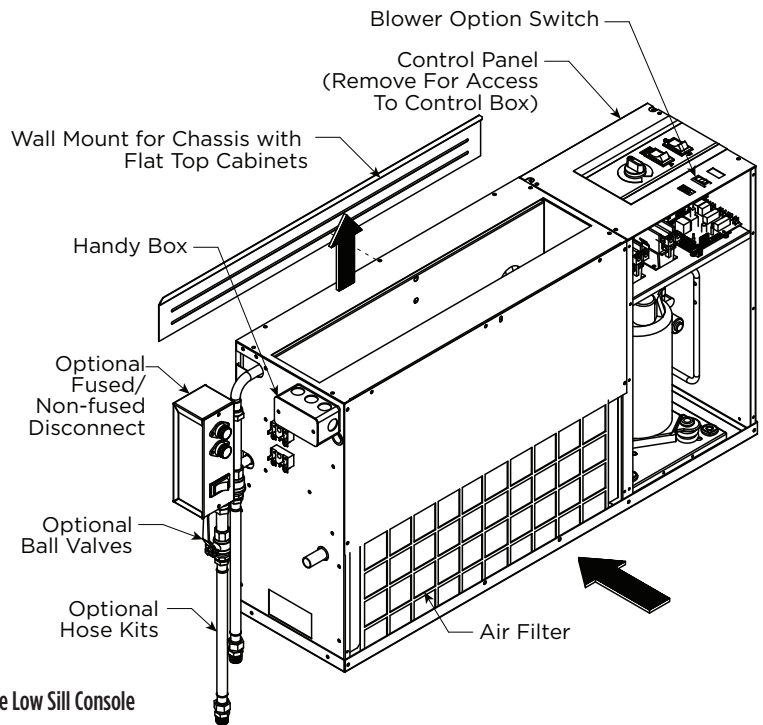



ASK US HOW YOU CAN SAVE UP TO 50% ON YOUR NEXT COMMERCIAL PROJECT

With the Inflation Reduction Act, projects completed with a geothermal loop and heat pumps may qualify for:

- 30% bonus rate
- 10% bonus rate for domestic content
- 10% Energy Community bonus
- Up to \$5 per square foot tax deduction
- 5-year accelerate depreciation and a 1-year bonus depreciation



SCAN TO LEARN MORE

AHRI/ISO 13256-1 PERFORMANCE RATINGS

PSC/ECM Motors

AHRI/ASHRAE/ISO 13256-1
English (IP) Units

Model	Flow Rate		Water Loop Heat Pump				Ground Water Heat Pump				Ground Loop Heat Pump			
			Cooling EWT 86°F		Heating EWT 68°F		Cooling EWT 59°F		Heating EWT 50°F		Cooling EWT 77°F		Heating EWT 32°F	
	gpm	cfm	Capacity Btuh	EER Btuh/W	Capacity Btuh	COP	Capacity Btuh	EER Btuh/W	Capacity Btuh	COP	Capacity Btuh	EER Btuh/W	Capacity Btuh	COP
009	2.5	300	8,500	13.4	10,500	4.4	10,200	22.5	8,700	3.8	9,000	16.0	6,700	3.1
012	3.5	350	10,500	12.3	14,400	4.3	12,400	19.5	11,800	3.7	11,000	14.2	9,500	3.5
015	4.5	450	13,500	13.6	17,000	4.9	16,200	22.0	14,000	4.1	14,200	15.9	10,500	3.4
018	5.5	500	16,200	12.5	21,000	4.4	19,000	19.6	17,000	3.7	16,600	15.1	13,300	3.1

5/24/18

Cooling capacities based upon 80.6°F DB, 66.2°F WB entering air temperature
Heating capacities based upon 68°F DB, 59°F WB entering air temperature
All ratings based upon 208V operations.

Voltage Availability

Voltage	Low Sill Console			
	009	012	015	018
115/60/1	•	•		
208-230/60/1	•	•	•	•
265/60/1	•	•	•	•

6/10/13



BR1012CN 06/23



visit us at waterfurnace.com