

# LAB POWDER BOOTH



The versatile lab powder booth is engineered for small batch, manual applications and includes a compact plenum design offering a larger work area. Extremely quiet and environmentally friendly, this booth is a perfect solution for operations with limited finishing space.

## Features

- RTT booths are constructed from heavy duty 18-gauge, prime quality galvanized steel and engineered with corresponding support structure.
- All panels and support members are laser cut and precision formed for consistent fit allowing for easy nut and bolt assembly.
- Dwyer Purge Control assures the safe operation of the coatings enclosure by maintaining the airflow at design levels. During operation, powder accumulates on the cartridge filters. As the cartridge filters load, airflow decreases and negative pressure rises within the air handler. The adjustable timer activates a system of air purging valves that clear the cartridge filters of accumulated powder to ensure maximum life.
- LED lighting is constructed of 22-gauge steel which is powder coated white, and available in 4000 and 8000 lumen models. E-Lights are ETL listed for US and Canada with Class 1 Division 2, Group A, B, C, D and Class 2 division 2, Group F and G ratings.
- Control Equipment Includes NEMA 12 UL and ETL listed control panel mounted to the side of the collector module, factory wired and tested. Automatic or manual cartridge filter pulse down mode; Door mounted magnehelic gauge for cartridge filter monitoring; VFD to control fan speed; Pressure switches to monitor final filter pressure and warn/shutdown if pressure exceeds set point.
- Variable Frequency Controlled Fan (VFD) is connected to the fan motor, this allows for the fan to turn at any speed so that optimum airflow within the booth can be achieved. The VFD can also save on operating costs due to the reduced amp load on the motor, and the ability to slowly ramp the motor up to speed.
- Base Assembly Rollaway base assembly cabinet and floor support is fabricated with 3" channel steel and formed 10-gauge mild steel (welded construction). The finish will be white powder coating.
- RTT booths meet and/or exceed quality performance standards and all applicable OSHA and NFPA regulations.

## Options

- Air manifolds
- Touch screen controls
- Durable powder coated white



Control panel and VFD included



# LAB POWDER BOOTH



## Selecting a Booth Size

RTT can design and build booths in a variety of sizes and configurations. Although our team can engineer custom sizes to fit your needs, below are standard sizes that are pre-engineered and available for quick shipment.

Model Number	Interior Dimensions			Exterior Dimensions			Total CFM	Filters	Fan Spec			Lights S&G
	Width	Height	Length	Width	Height	Length			Qty	Dia	HP	
LPB-05-05-03-00-S	5'-0"	5'-0"	3'-0"	5'-3"	8'-4"	5'-8"	1600	3	1	12 1/4"	3	1

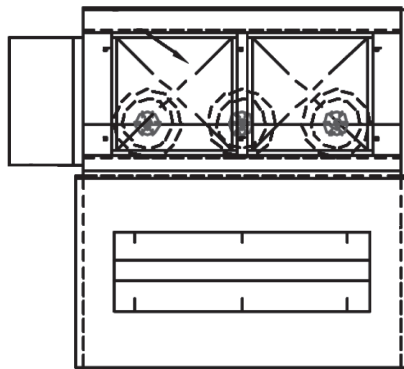

Plan View

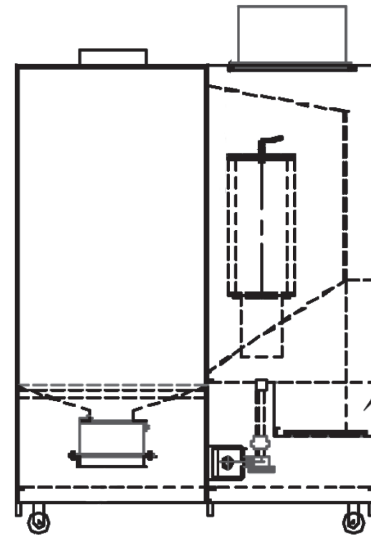

Right Elevation

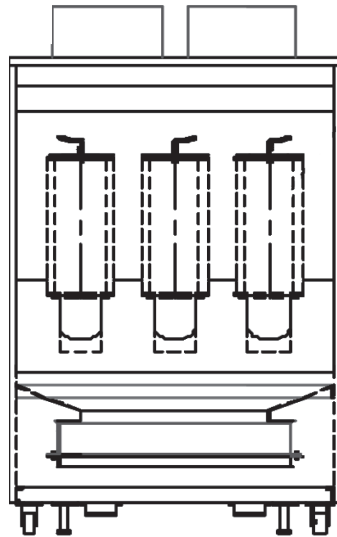

Front Elevation