

Model 282L Single Point Insertion Electromagnetic Flow Meter 1" and 2" Sensors

Installation, Operation and Maintenance Manual

for use with Procomm GO Converter



30125-74 Rev. 1.1
November 2, 2022

Contents

SAFETY SYMBOLS AND WARNINGS	1
Safety Symbols	1
Safety Warnings	1
1.0 SPI MAG DESCRIPTION OF COMPONENTS	2
1.1 Overview	2
1.2 Flow Calculation	3
1.3 Profiling Information.....	3
1.4 Full Pipe Sensors.....	3
2.0 PARTS DIAGRAMS	4
3.0 SENSOR PROBE INSTALLATION	5
3.1 Site Selection	5
3.2 Sensor Clearance.....	5
3.3 Pipe Valve Installation.....	6
3.4 Sensor Assembly Installation	6
3.5 Inserting The Sensor	7
3.6 Clean Water Sensor Position	7
3.7 Raw Water Sensor Position.....	8
3.8 Sensor Insertion Tool.....	8
4.0 INSTALLING THE CONVERTER AND CABLES	9
4.1 Example Remote Mount Configuration	9
4.2 Mounting the Converter	9
4.3 Installing Cables through Cable Glands and Conduit	10
4.4 Pulling Sensor Cable Through Electrical Conduit	10
4.5 Cable Gland Assignment for Wiring Harnesses	11
5.0 INTERNAL WIRE CONNECTION	11
5.1 Terminal Block Diagram and Grounding Lug	11
5.2 Wiring Diagrams	12
5.3 Optional Smart Output Hook Up	13
6.0 EXTERNAL WIRE CONNECTION	13
6.1 Power Options	13
6.2 DC Power Cable (Optional).....	13
6.3 4-20mA Current Loop	14
6.4 Pulse Output Cable (Optional)	14
6.5 Solar Panel Option	15
7.0 BATTERY INSTALLATION AND REPLACEMENT	16
8.0 OPERATION	20
8.1 General	20
8.2 Activating the Display.....	20
8.3 Converter Boot	20
9.0 CONVERTER CONFIGURATION	21
10.0 ERROR MESSAGES FOR TROUBLESHOOTING	21
11.0 SENSOR REMOVAL	22
12.0 MAINTENANCE	22
13.0 SPECIFICATIONS	23
14.0 SPI MAG ORDERING INFORMATION	26
15.0 CONVERSION TABLES	27
WARRANTY	28

SAFETY SYMBOLS AND WARNINGS

Safety Symbols

Throughout this manual are safety warning and caution information boxes. Each warning and caution box will be identified by a large symbol indicating the type of information contained in the box. The symbols are explained below:



This symbol indicates important safety information. Failure to follow the instructions can result in serious injury or death.



This symbol indicates important information. Failure to follow the instructions can result in permanent damage to the meter or installation site.

Safety Warnings

When installing, operating, and maintaining McCrometer equipment where hazards may be present, you must protect yourself by wearing Personal Protective Equipment (PPE) and be trained to enter confined spaces. Examples of confined spaces are manholes, pumping stations, pipelines, pits, septic tanks, sewage digesters, vaults, degreasers, storage tanks, boilers, and furnaces.

You must follow all state and local laws, as well as Occupational Safety And Health Administration (OSHA) regulations concerning Personal Protective Equipment, confined-space entry, and exposure to bloodborne pathogens. Specific requirements can be found in the OSHA section of the Code of Federal Regulations: *29 CFR, 1910.132 - 1910.140, Personal Protective Equipment; CFR Title 29, Part 1910.146, Permit-Required Confined-Spaces; and 29 CFR, 1910.1030, Bloodborne Pathogens.*



WARNING!

Incorrect installation or removal of SPI Mag meters can result in serious injury or death. Read the instructions in this manual on the proper procedures carefully.



WARNING!

Never enter a confined space without testing the air at the top, middle, and bottom of the space. The air may be toxic, oxygen deficient, or explosive. Do not trust your senses to determine if the air is safe. You cannot see or smell many toxic gases.



WARNING!

Never enter a confined space without the proper safety equipment. You may need a respirator, gas detector, tripod, lifeline, and other safety equipment.



WARNING!

Never enter a confined space without standby/rescue personnel within earshot. Standby/rescue personnel must know what action to take in case of an emergency.



WARNING!

Pressurized pipes should only be hot tapped, cut, or drilled by qualified personnel. If possible, depressurize and drain the pipe before attempting any installation.



WARNING!

Carefully read all safety warning tags attached to the meter.

1.0 SPI MAG DESCRIPTION OF COMPONENTS

1.1 Overview

The SPI Mag Model 282L flowmeter combines an innovative sensor with a comprehensive electronics package to provide accurate flow measurement for full-pipe flow monitoring applications.

The insertable sensor (available for one-inch and two inch taps) uses electromagnetic technology to measure water velocity. The streamlined, debris-shedding sensor shape allows the SPI Mag to be used under many flow conditions.

SPI Mag has many features to suit a wide variety of applications, and is easily set up using the keypad and readouts. Refer to the converter manual shipped with your meter system.



NOTE

The converter and sensor are supplied as a matched system. (Figure 1 and Figure 2) Verify the system serial numbers on both the converter and sensor match. This will ensure a properly calibrated system. The System Serial Numbers begin with MM20##### and are located on the side of the converter and on a tag near the end of the sensor cable.



Figure 1. Procomm Series remote mount converter

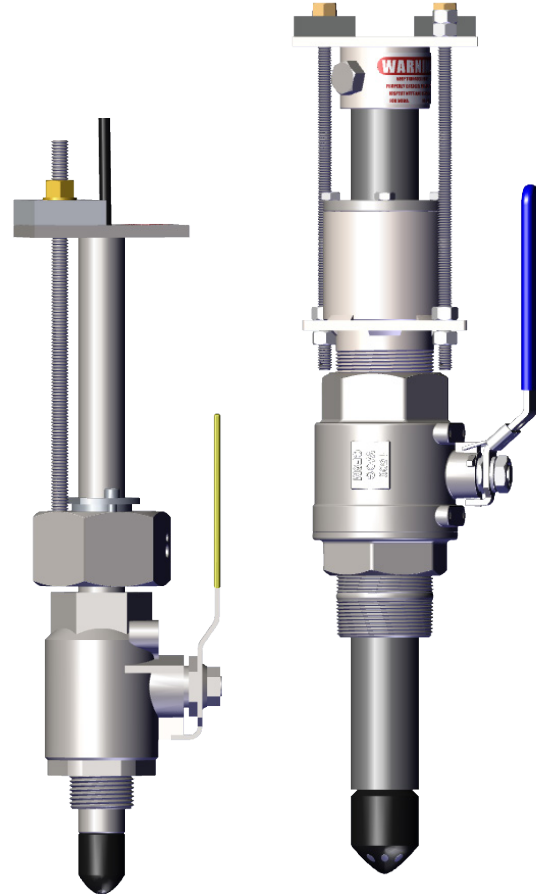

Figure 2. 1" and 2" Sensor with Insertion Hardware

The valves are optional or supplied by the customer, and are shown for illustration only.

1.2 Flow Calculation

The velocity measurements provided by the full-pipe sensor are used to calculate flow. Flow (also known as Q, as the flow rate, or as throughput) is the amount of fluid moving through a pipe in a period of time. For example, if 100 gallons of water move past the sensor in one minute, the flow is 100 gallons per minute (GPM).

To calculate the flow, two things are needed: The cross-sectional area of the pipe and the average velocity.

Cross-sectional area is found using the inside diameter of the pipe.

I **NOTE:** It is required that the exact inside diameter of the pipe is input into the flow computer for the SPI Mag to provide accurate flow data.

Average velocity is found using the sensed velocity (measured by the sensor). A site calibration is performed to determine the velocity profile. This allows the flowmeter to calculate the average velocity from the sensed velocity.

Flow is calculated by using the Continuity Equation:

$$\text{Flow} = \text{Average Velocity} \times \text{Area}$$

1.3 Profiling Information

For information about the Profiling and Site Calibration, refer to these documents:

- One Inch Full Pipe Sensor Installation and Profiling Guide, Lit.# 24510-58.
- Two Inch Full Pipe Sensor Installation and Profiling Guide, Lit.# 24510-59.

1.4 Full Pipe Sensors

The full pipe sensor makes use of Faraday's Law of Electromagnetic Induction to measure water velocity. Faraday's Law states a conductor, moving through a magnetic field, produces a voltage.

Because water is a conductor, water moving through a magnetic field produces a voltage. The magnitude of the voltage is directly proportional to the velocity of the water. The sensor generates an electromagnetic field, creating a voltage in the water. The two velocity electrodes, along with the ground electrode measure this voltage. A faster water velocity produces a higher voltage. By accurately measuring this voltage, the velocity is determined. (Figure 3)

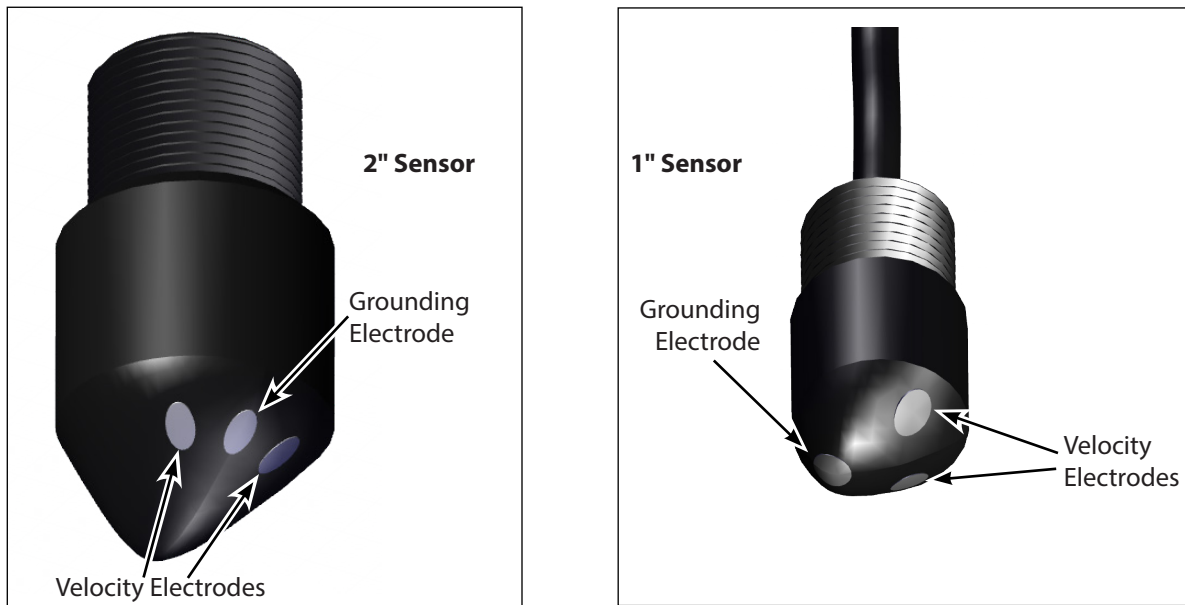

Figure 3. 2" and 1" 282L Sensors

2.0 PARTS DIAGRAMS

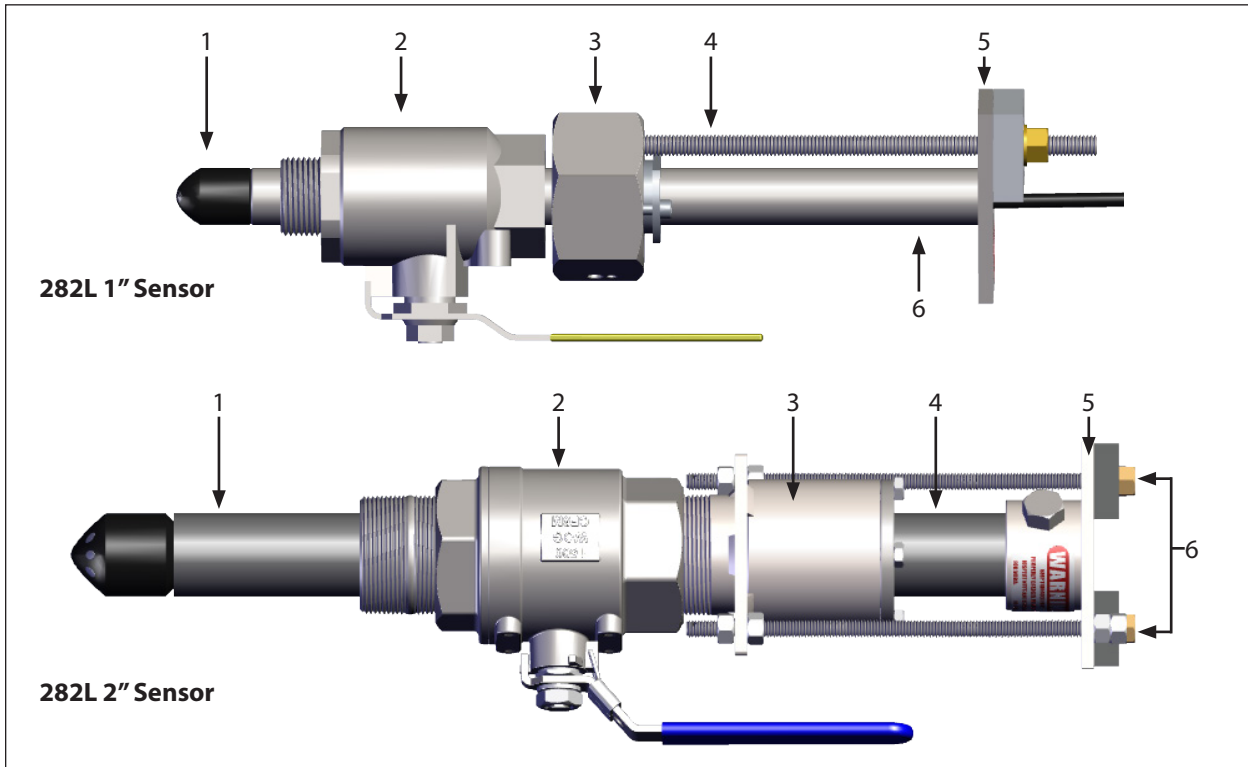

Figure 4. Parts Diagrams

Item Number	Part Name and Part Number
1	Sensor Assembly 1" 60080X001 Sensor Assembly 2" 600028X001
2	Ball Valve 1" Bronze 43801 Ball Valve 2" Bronze 43055
3	Compression Seal Assembly 1" 800003801 Compression Seal Assembly 2" 42205
4	1" Insertion Tube with Cap 12" 42292 24" 42292-1 36" 42292-2 2" Insertion Tube without Cap 18" 42198 24" 42198-1 30" 42198-2 Over 30" use SS tube 42204-xx
5	Insertion Tube Cap 1" Consult Factory Insertion Tube Cap 2" 55042
6	3/8" SS Long Threaded Rod 42199

NOTE: Valves are optional or supplied by user.

3.0 **SENSOR PROBE INSTALLATION**

Please read the following information before installing the SPI Mag Sensor

3.1 **Site Selection**

Install the sensor at an adequate distance from elbows, T-junctions, Y-junctions, active valves. Whenever possible, install the sensor upstream from a bend or junction.

3.2 **Sensor Clearance**

The sensor will protrude from the pipe when installed demanding sufficient clearance (distance H, in Figure 5 below) from any obstruction for the purposes of installation and removal.

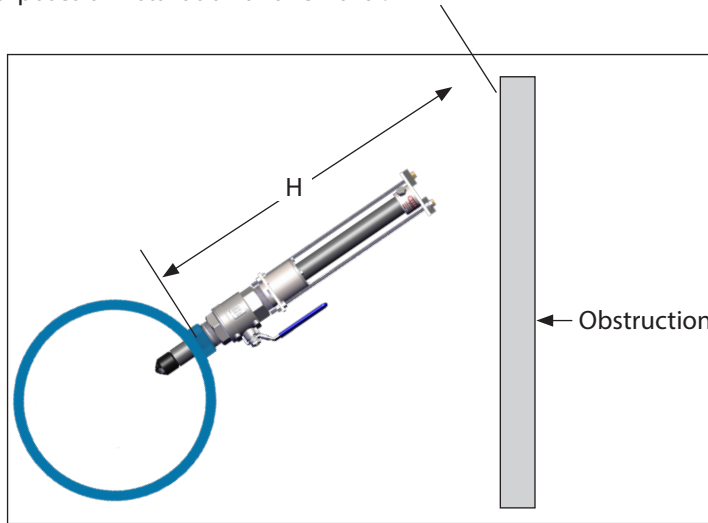

Figure 5. Sensor Clearance Distance

Distance H above is estimated by adding three measurements:

1. The height from the outer pipe wall to the top of the installation valve
2. The length of the meter (see the table below)
3. Additional 9" of working space

	Insertion Tube Length	Overall Sensor Length
1" 282L	12"	18.25"
	24"	30.25"
	36"	42.25"
2" 282L	18"	24.25"
	24"	30.25"
	30"	36.25"

3.3 Pipe Valve Installation



WARNING!

Pressurized pipes should only be hot tapped, cut, or drilled by qualified personnel using high quality saddles, valves and stainless steel nipples. If possible, depressurize the pipe before attempting any installation.

Install a 2" (50mm) full port valve or corporation stop with a 2" (50mm) NPT female pipe thread output for the 2" sensor, or a 1" (25mm) full port valve or corporation stop with a 1" (25mm) NPT female pipe thread output for the 1" sensor. Follow any and all installation instructions provided for the valve that you have chosen. The valve or corporation stop can be installed onto a welded coupling or pipe saddle. See Figure 6.



IMPORTANT: The MINIMUM port inside diameter for all installation valves is 1-7/8" (48mm).

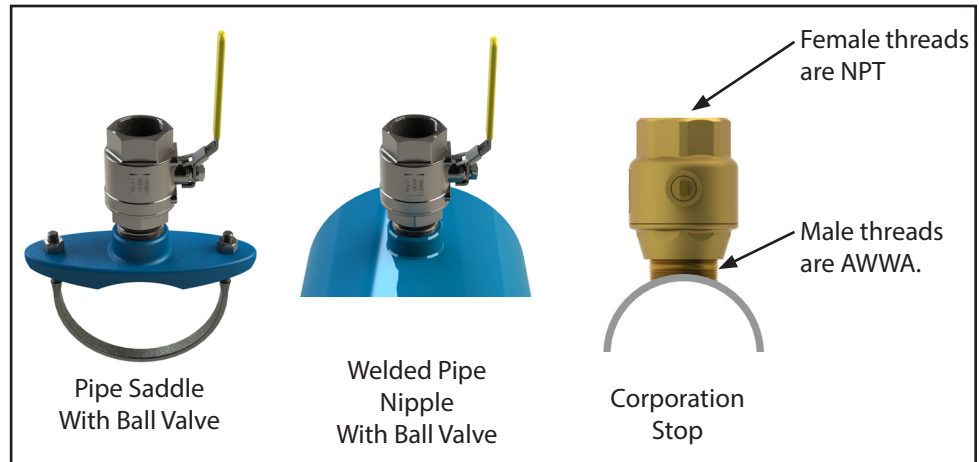

Figure 6. Installation Valve Options

3.4 Sensor Assembly Installation

The sensor assembly uses a compression seal, which keeps the sensor watertight when the pipe is under pressure. (Figure 7) Care must be taken when installing the sensor, to avoid leaks.

1. Visually inspect all elements of the installation to ensure they are structurally sound and of high quality materials, including all welds, couplings and nipples. To prevent future corrosion, nipples should be high quality stainless steel.
2. Put a generous amount of the pipe sealant (not supplied with the sensor) on the compression seal threads. (Teflon tape may also be used.) **NOTE:** if pipe sealant gets on the sensor electrodes the velocity signal may be lost.
3. Place the compression seal threads over the pipe valve. Turn the entire sensor assembly clockwise to secure the assembly to the valve.
4. The seal is secure when a large amount of force is required to turn the assembly. Line up the arrow (on the top plate) with the direction of the flow.

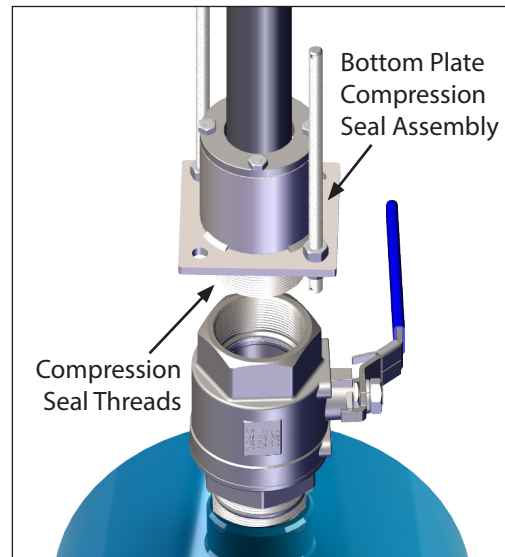

Figure 7. Sensor Installation

3.5 Inserting The Sensor



WARNING!

The compression seal/sensor assembly may be under pressure. Serious injury may result if proper procedures are not followed. Do not attempt to install the sensor without the restraining rods fully assembled.

Ensure the compression seal is only hand tightened.

1. Barely crack open the valve and tighten the compression seal as required to minimize leaks. A towel draped around the compression seal can reduce spray if necessary.
2. Open the valve completely. Failure to open the valve completely will cause the valve to scrape the sensor during insertions and may result in permanent damage to the sensor.
3. Insert the sensor into the pipe by simultaneously rotating clockwise the two captive nuts on the top plate for the 2" sensor, and the single captive nut on the 1" sensor. (Figure 8) For the two captive nuts on the 2" sensor use the two ratchet wrenches provided. It is recommended that the sensor insertion tool (p/n 75031) be used to rotate the captive nuts on the 2" sensor to ensure the top plate compresses evenly. See section 3.8 and Figure 12.



IMPORTANT

On the 2" installation hardware, if the captive nuts are not tightened simultaneously, the top plate will become crooked and cause the sensor to be inserted at an angle and may cause permanent damage to the sensor.

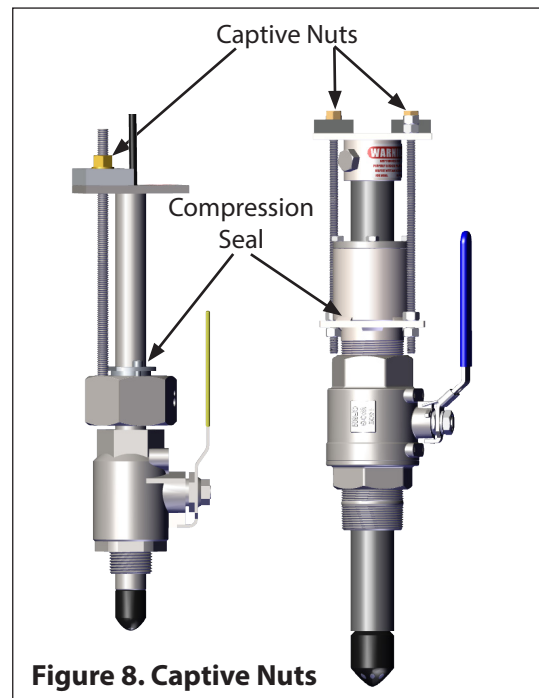

Figure 8. Captive Nuts

3.6 Clean Water Sensor Position

If the flow is clean water the sensor can be placed at 1/8 of the inside diameter. To position the sensor at 1/8 of the ID, follow the instructions below:

- Measure the tube from the top of the cap to the end of the sensor to find the tube length (TL).
- Calculate (1/8 ID): $1/8 \text{ ID} = 0.125 \times \text{Pipe ID}$
- Add wall thickness to 1/8 ID.
- Calculate distance A: $A = \text{TL} - (1/8 \text{ D} + \text{WT})$
- Set the top edge of the insertion tube cap distance A from the pipe.

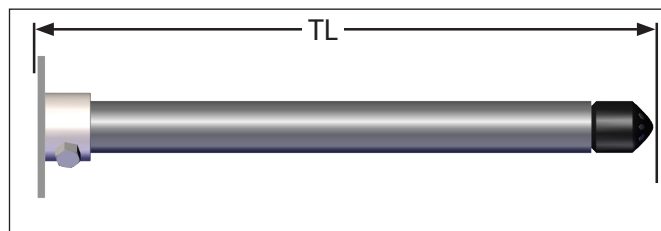

Figure 9. Tube Length (TL)

If the flow is clean water, the sensor can be left at the 1/8 D position. (Figure 10) Do not leave the sensor in this position for raw waste water because debris could collect on the sensor and affect the velocity readings. In waste water applications, position the sensor at location 0.00. See section 3.7.

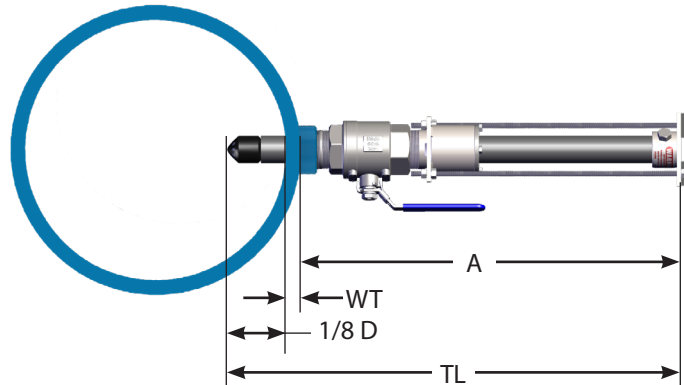

Figure 10. 1/8 ID Position

3.7 Raw Water Sensor Position

The operation position for raw waste water and sludge is at sensor location 0.00 to prevent debris from collecting on the sensor and affecting velocity readings. To position the sensor at this location follow the instructions below:

- Calculate distance A by subtracting the pipe wall thickness (WT) and 3/4" from length C. See Figure 11 for Length C (Tube Length).
- Position the top edge of the insertion tube cap distance A from the pipe.

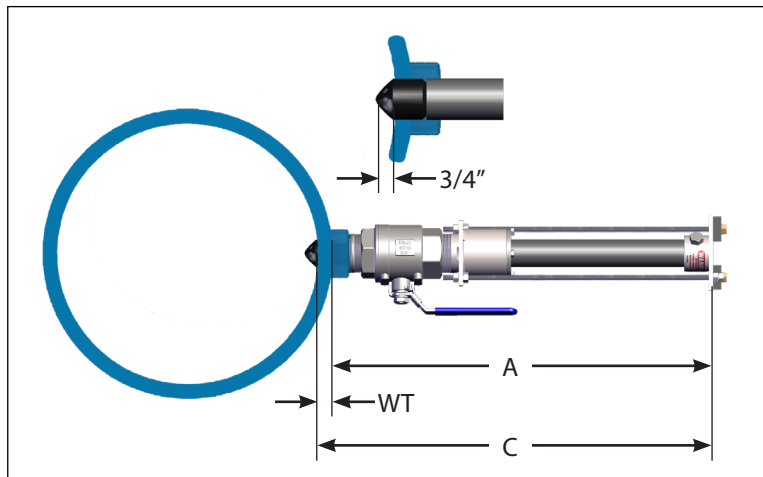

Figure 11. 0.00 Position

3.8 Sensor Insertion Tool

McCrometer recommends using a sensor insertion tool (Figure 12) (P/N 75031) to help with inserting the sensor and to avoid any damage to the sensor. Place the profiling insertion tool over the captive nuts and lock it into place with spring locks located on the bottom of the tool. Using the provided wrench rotate the high gear shaft clockwise until the bottom of the sensor reaches the far wall of the pipe.

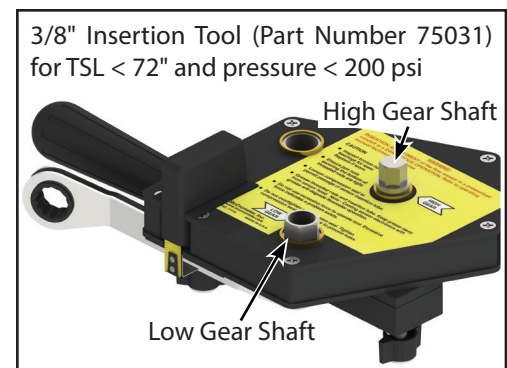

Figure 12. Sensor Insertion Tool

4.0 INSTALLING THE CONVERTER AND CABLES

4.1 Example Remote Mount Configuration

You will need to prepare the location where you will install the remote converter. The location cannot be further from the flow meter than the length of the 25' cable. This must be planned in advance because **the cable cannot be lengthened**. Doing so will alter the calibration accuracy between the meter and the converter and void the warranty.

Install the flow meter as described in section 3.0. Mount the converter and connect the cable to the meter's junction box and the converter's external connection. Figure 13 below shows an example of a remote mount installation with an optional Smart Output connection.

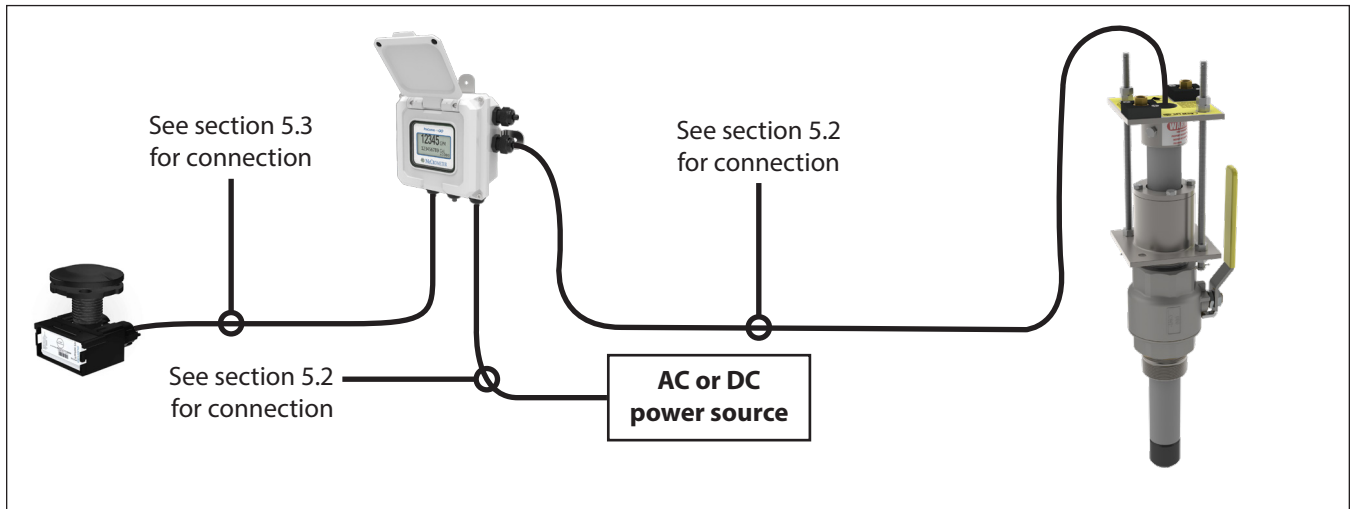

Figure 13. Example remote mount configuration

4.2 Mounting the Converter

Note: This applies to the remote mount converter only.

If possible, mount the converter in an electronics shed or environmental enclosure. The sun shield should be oriented in a direction to reduce sun damage and ensure readability. This electronic unit is rated IP67 for temporary flooding.

There is a stainless steel mounting plate attached to the back of the ProComm GO converter, which is used to mount the converter to a solid, flat surface using four bolts (Figure 14). Mounting plate feet are located at the top, bottom, left, and right sides.

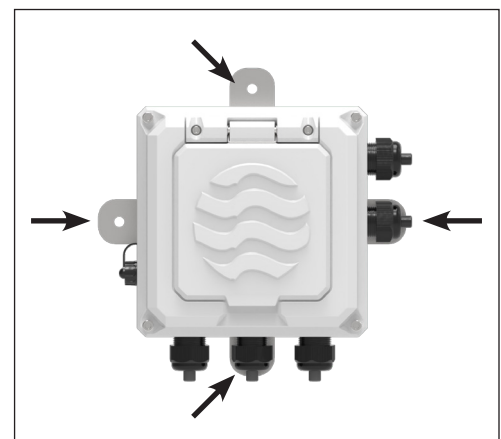

Figure 14. Mounting converter to solid surface

4.3 Installing Cables through Cable Glands and Conduit

All electrical cables enter the converter through compression fittings or optional customer-supplied conduit located on the side or bottom of the converter (Figure 15 and Figure 16). Ensure that all compression glands are properly tightened and all unused fittings are plugged so the case remains sealed.

The power cable and wiring harnesses are each assigned specific cable glands where they will pass through into the converter. See section 4.5 for cable gland assignment for wiring harnesses and section 5.2 for wiring diagrams.

All cable compression glands must be properly tightened to prevent moisture intrusion and maintain the IP67 rating. To insure IP67 rating, use only round cable 0.24" to 0.47" in diameter.



Figure 15. Compression fittings

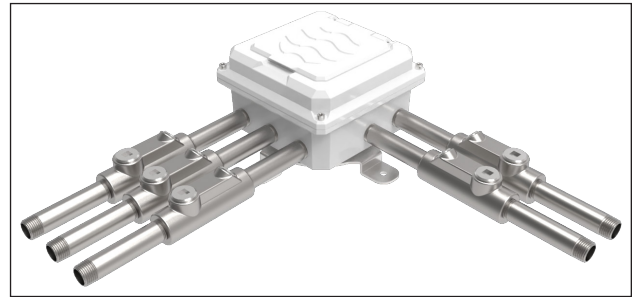

Figure 16. Remote mount converter with conduit pass-throughs



Attaching conduit directly to the enclosure may introduce dangerous gasses and moisture into the enclosure creating a dangerous condition, and will remove the enclosure's IP67 rating.

Damage caused by attaching conduit to the enclosure or altering the enclosure in any way is not covered by the warranty.



IMPORTANT: Do not cut or alter the cable length on power or signal cables!

Connections to the sensor must be made with cable supplied by McCrometer specifically for that purpose. Do not substitute the supplied cable with other types of cable, even for short runs. For repairs or added lengths of cable, the entire cable between the sensor and the converter must be replaced. (Consult factory for replacement cable.)

4.4 Pulling Sensor Cable Through Electrical Conduit

It is very important to protect the end of the sensor cable when pulling it through a conduit. Water can accumulate in low portions of conduit. Always use a cable cover, or similar method, to seal the end of the cable against water when pulling the cable through conduit (see Figure 17). This will ensure proper operation of the meter.

NOTE

Cable cover is not provided.

1. Tie a rope or cable-snake securely around the middle of the cable cover.
2. Carefully pull the rope or snake until the sensor cable end clears the conduit.
3. Bring the cable end to the converter location. If necessary, secure the cable so that it does not fall back through the conduit.
4. Remove the cable cover by pulling the rip wire. The cable cover will tear off (discard the cover).



CAUTION: Do not cut the cable cover off. Doing so may damage the sensor cable and adversely effect the calibration of the meter.

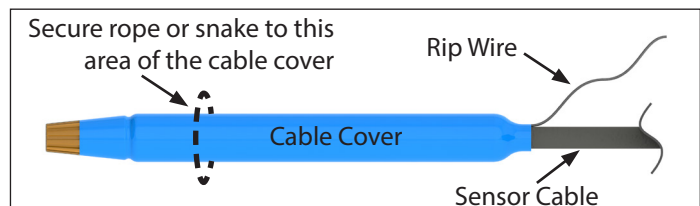

Figure 17. Cable cover

4.5 Cable Gland Assignment for Wiring Harnesses

Port assignment

- 1 - Outputs
- 2 - Outputs
- 3 - Power
- 4 - Coils
- 5 - Electrodes

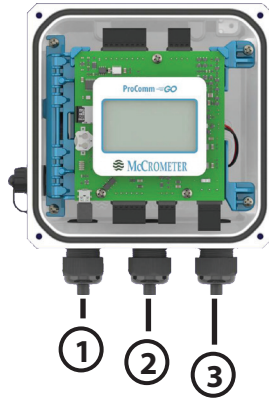

Figure 18. Meter mount view

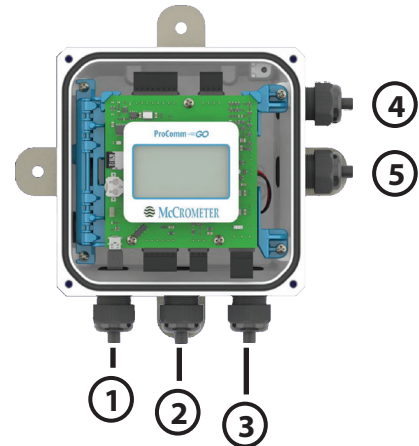

Figure 19. Remote mount view

5.0 INTERNAL WIRE CONNECTION

This section describes cable and wire harness connection inside the converter. Section 6.0 describes wire connection for all peripherals outside of the converter, including pulse output and external power options.

5.1 Terminal Block Diagram and Grounding Lug

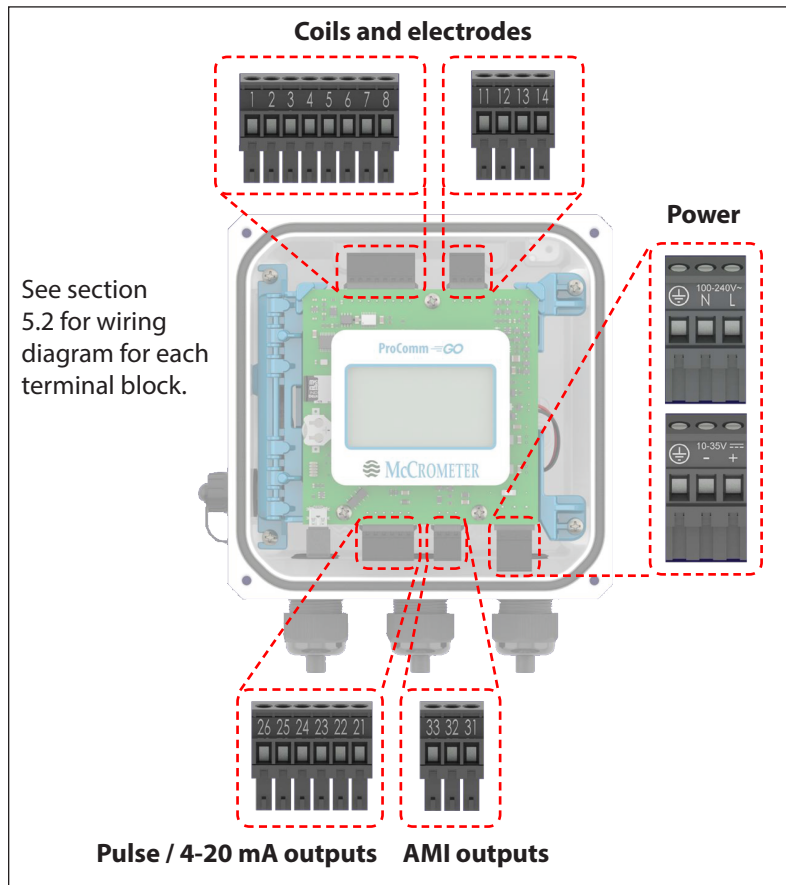

Figure 20. Terminal blocks

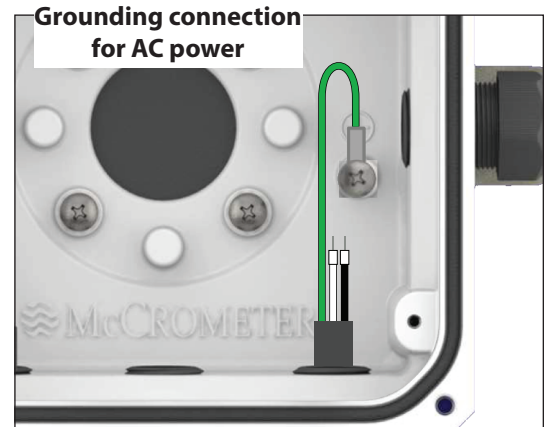
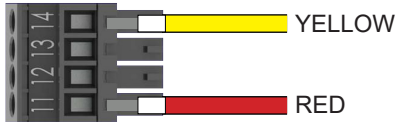

Figure 21. Grounding lug

5.2 Wiring Diagrams

TERMINAL BLOCK ASSIGNMENTS

Coils Harness



Terminal	Port	Wire Color
8	4	Green/Yellow
11	4	Red
14	4	Yellow

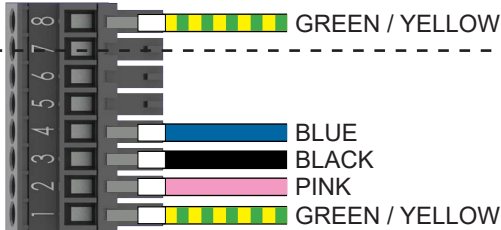

Electrodes Harness

Terminal	Port	Wire Color
1	5	Green/Yellow
2	5	Pink
3	5	Black
4	5	Blue

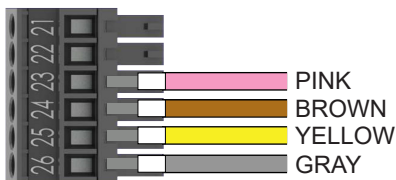

Pulse Output Harness

Terminal	Port	Wire Color
23	1	Pink
24	1	Brown
25	1	Yellow
26	1	Gray

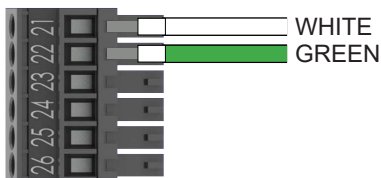

4-20 mA Output Harness

Terminal	Port	Wire Color
21	1	White
22	1	Green

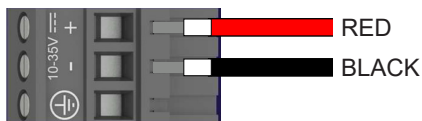

DC Power Harness

Terminal	Port	Wire Color
Negative	3	Black
Positive	3	Red



AC Power Harness

Terminal	Port	Wire Color
Chassis lug	3	Green
Neutral	3	White
Load	3	Black



To complete AC power connection, connect green ground jumper as shown on previous page.

5.3 Optional Smart Output Hook Up

The converter comes pre-wired with an interconnection that should readily connect to most AMI transceivers. Where interconnective devices are not mechanically compatible or where non-standard wiring is encountered, the installer can opt to remove the connector from the end of the converter's interface cable and make direct connection via the wiring table shown at right. (Figure 22)

- Signals and associated wire colors in the McCrometer SmartOutput™ interface cable are identified together in the top row of the table at right.
- Corresponding wire colors for transceivers from each compatible AMI vendor are identified in the columns under the top row.

	Sensus	Itron	Badger	Neptune	Elster
31	Black	Green	Black	Green	Black
32	Red	Black	Red	Black	Green
33	Green	Red	Green	Red	Red

Figure 22. AMI Interface Pinout

6.0 EXTERNAL WIRE CONNECTION

6.1 Power Options

Depending on output options and specific application position, you may choose to add additional power options to the battery powered converter. The 5W solar panel option (described in section 6.5) can extend battery life to 10-15 years. Additionally, you have the option of connecting external power of 10-32VDC or 100-240VAC.

6.2 DC Power Cable (Optional)

The cable contains wiring for both the optional 10-32VDC power to the meter, and the 4-20mA output from the meter. (Figure 23)

Note: Input power is for the converter only if that option was selected at time of purchase. The 4-20mA loop requires its own power supplied to the loop, not be used with red/black wires.

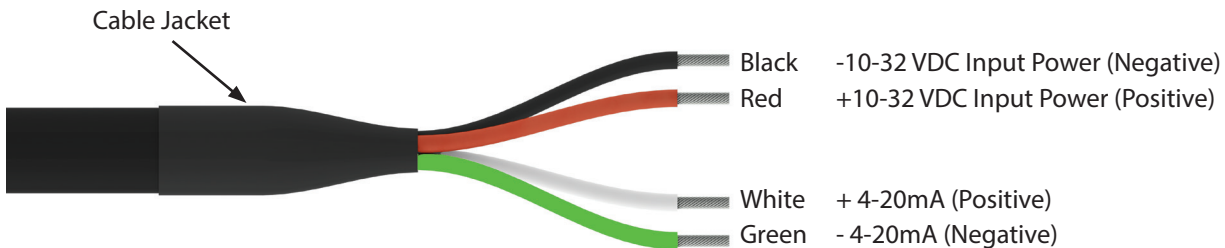

Figure 23. DC Power Cable Wiring Color Scheme (Optional)

6.3 4-20mA Current Loop

Output type: 4-20mA current loop

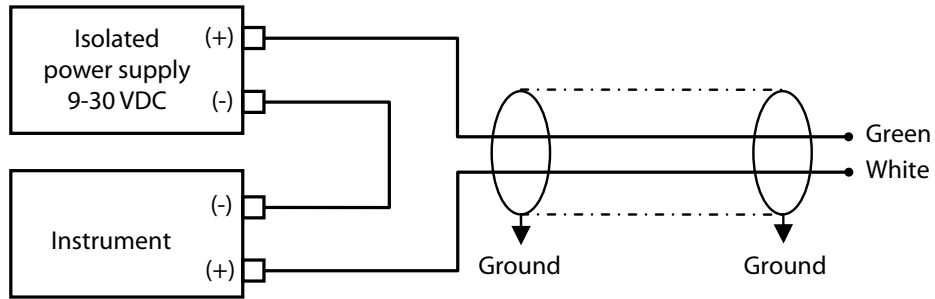

Figure 24. 4-20mA current loop

6.4 Pulse Output Cable (Optional)

The cable contains wiring for both pulse output 1 and pulse output 2. (Figure 25 and Figure 26)

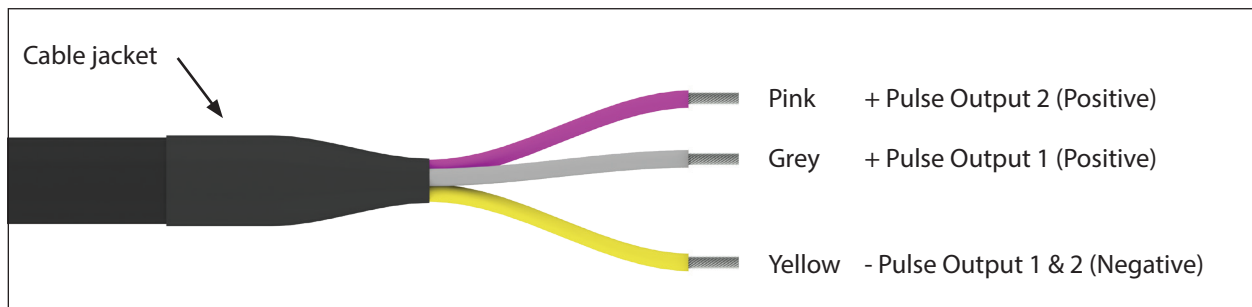

Figure 25. Quick connect pulse output cable wiring color scheme (optional)

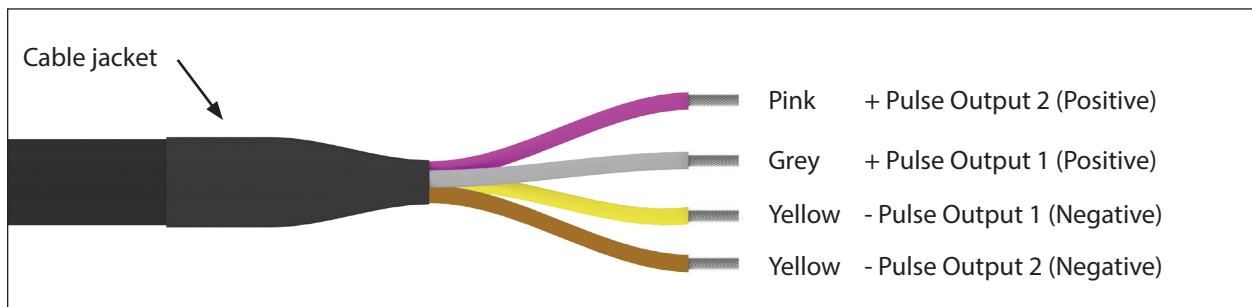

Figure 26. Hard wired pulse output cable wiring color scheme (optional)

6.5 Solar Panel Option

The solar panel provides power to the converter by converting sunlight into electrical energy to recharge the solar panels' rechargeable battery. Its nominal power output is 5W.

When the solar panel is installed and the cable has been run to the converter, connection inside the converter is the same as installing batteries. See Figure 27 below.

The solar panel comes complete with all accessories, except for the fixing rod.

I These instructions apply only to McCrometer-supplied solar panels with a rechargeable battery. Connecting directly to a solar panel could damage the converter.

1. Remove lid from converter base.
2. Rotate battery tray open.
3. Route solar panel output cable through the bottom left strain relief.
4. Secure strain relief on the shrink wrap (Detail A) to avoid leaks.
5. Plug solar panel output cable into battery terminal 1 (BAT1).
6. Plug triple D battery pack into battery terminal 2 (BAT2).
7. Close battery tray.

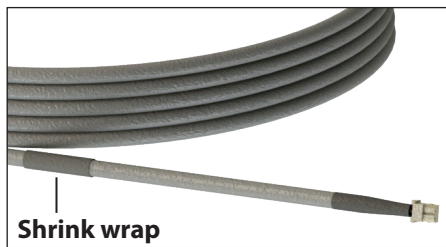
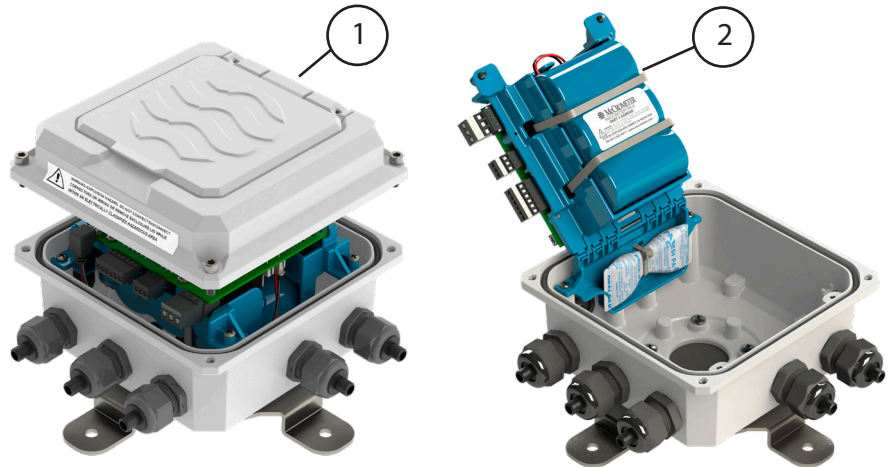

Detail A

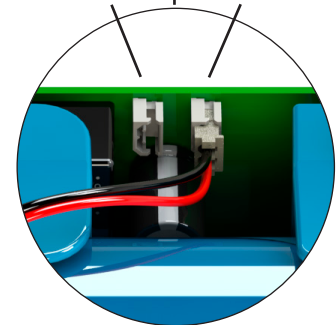
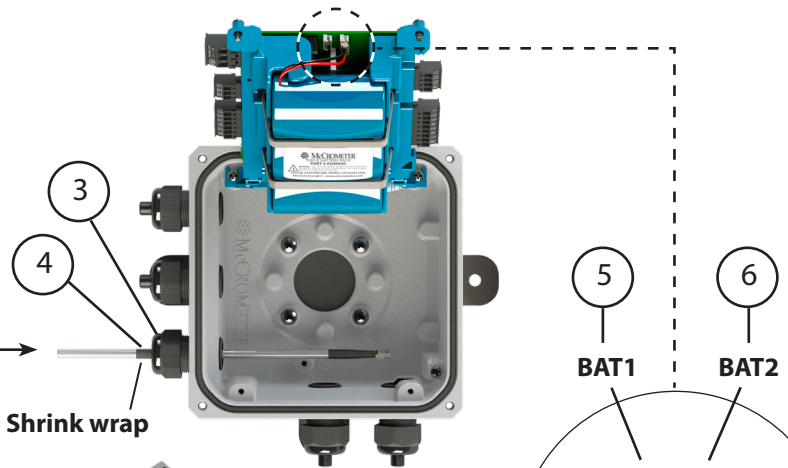

Detail B

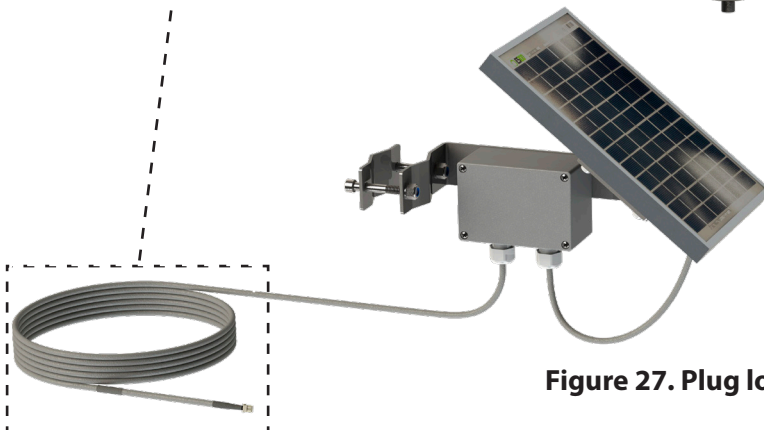

Figure 27. Plug location for solar panel









7.0 BATTERY INSTALLATION AND REPLACEMENT

This procedure applies to flow meters with the ProComm GO converter. It describes how to install batteries in a new meter and how to replace batteries using the replacement battery kit PGK01.

Before you begin:

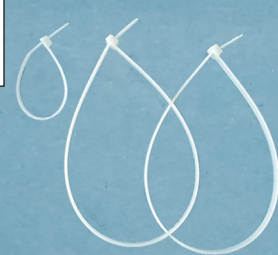
Check materials and tools to ensure you have everything you need.

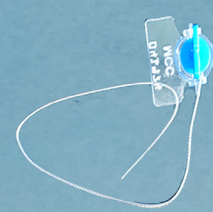
Materials Provided (shown in order of use)

<p>One triple D battery pack</p> 	<p>One double A battery pack</p> 	<p>Replacement cover gasket</p> 	<p>Molykote lubricant</p> 
<p>Zip ties: • 2 large • 1 small</p> 	<p>Dry pack</p> 	<p>Tamper proof wire seal</p> 	<p>Tool Required</p> <p>Wire cutters Phillips screwdriver 5/32" Allen driver</p> 

I. Removing the cover

- Cut off the tamper-proof seal and remove the wire from the security screw.
NOTE: This step is not required for battery installation in new meters.
- Remove screws holding the lid to the housing using a 5/32" Allen driver. Lift the lid up and place the lid upside hanging by the green ground wire.

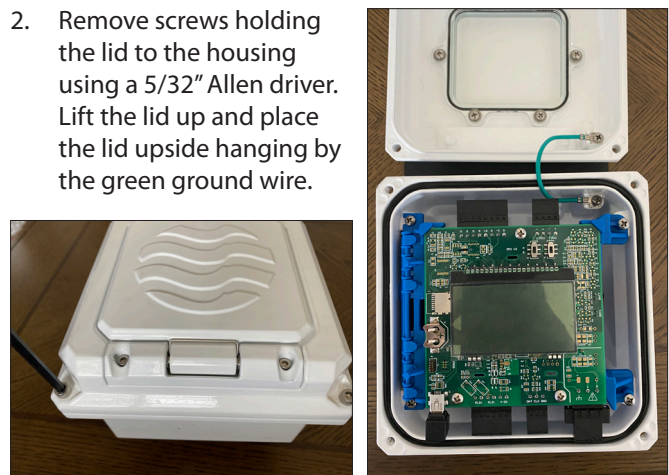
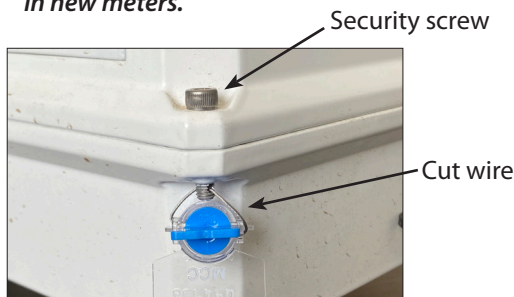

If you are replacing batteries with fresh batteries, continue to step 3.

If you are installing batteries in a new meter that does not have batteries already installed, go to step 9.

II. Removing the batteries

3. Unplug tall connectors to sensor, outputs, and power.

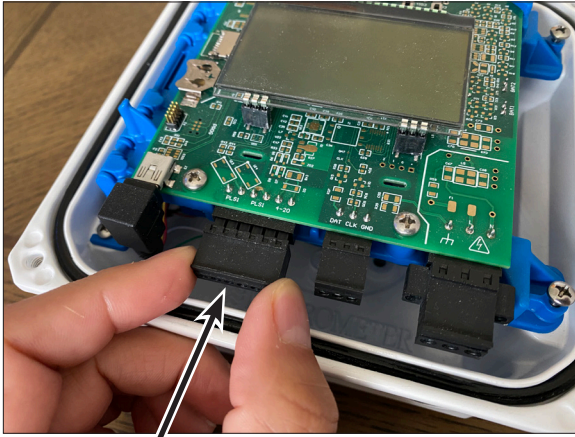

Connectors

4. Loosen the captive screws opposite of the hinge and lift the battery cover.

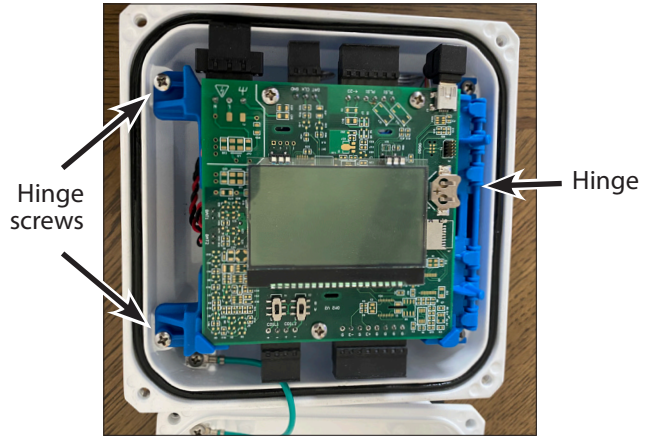

5. Unplug the batteries.

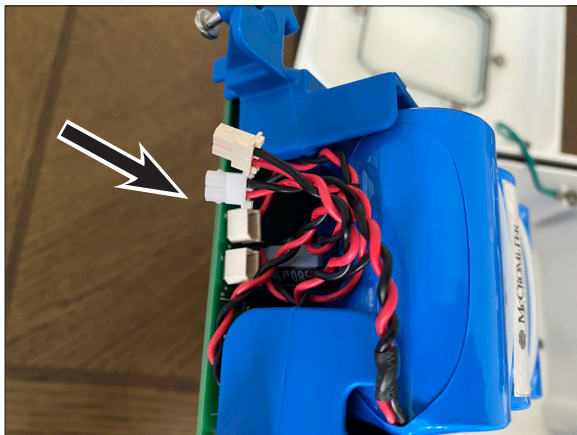

6. Cut the two zip ties securing the batteries.

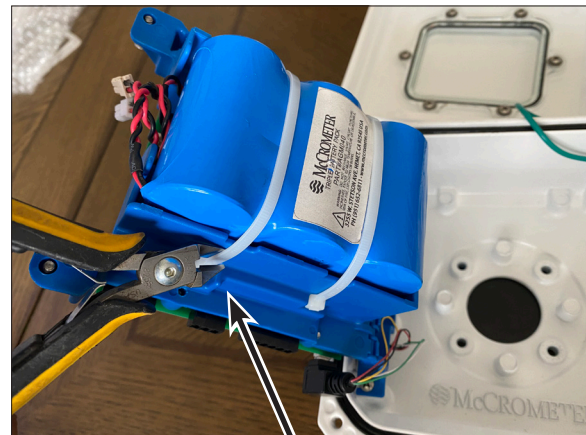

Zip ties

7. Remove the large battery pack.



Large battery pack

8. Remove the small battery pack located underneath. Pull the wires carefully from underneath the battery tray.

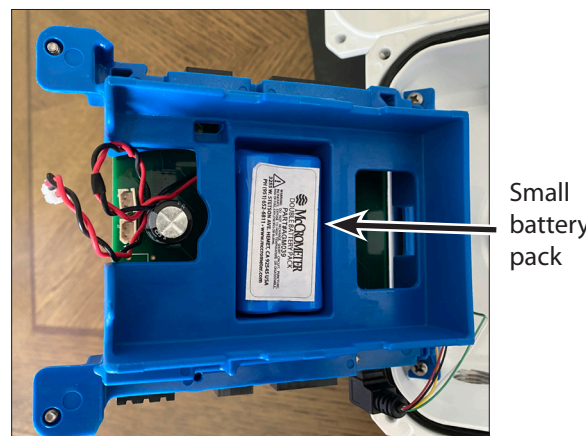

Small battery pack

III. Installing the batteries and restoring the power

9. Cut the zip tie holding the dry pack to the hinge on the converter base.

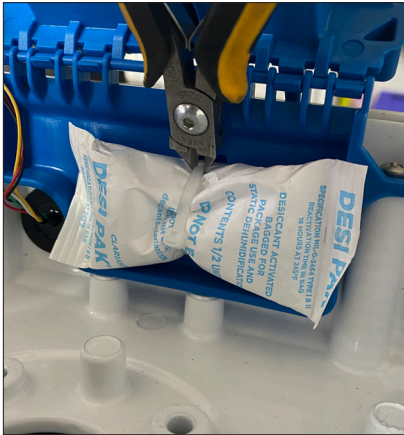

10. Pass the new zip tie through the slots in the internal hinge.

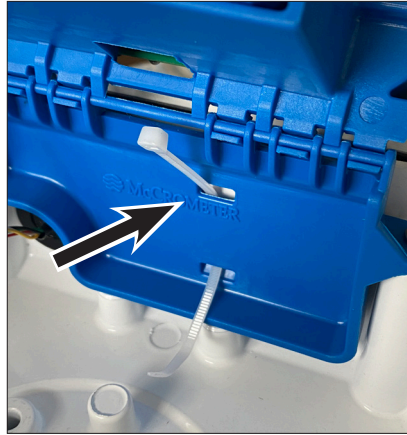

11. Wrap the new zip tie around the new dry pack and cut off the excess.



12. Pass the two large zip ties through the slots in the internal tray holder.

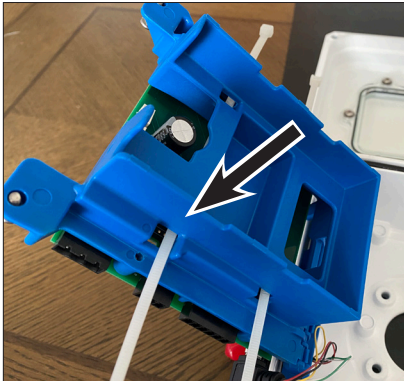

13. Place the small battery pack in the center pocket, making sure the wire leads go out through the opening.

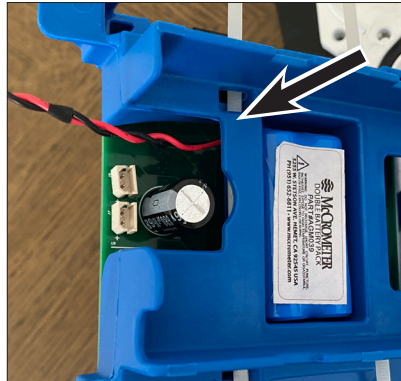

14. Place the large battery pack on the internal tray with wire leads passing through the slot.

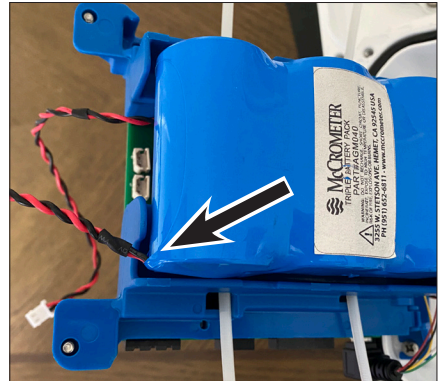

15. Secure the battery packs to the internal tray with the two large zip ties. Cut off the excess of each of the zip ties.



16. Plug the batteries into the circuit board.

- The large battery pack goes to connector B1.
- The small battery pack goes to connector B2.

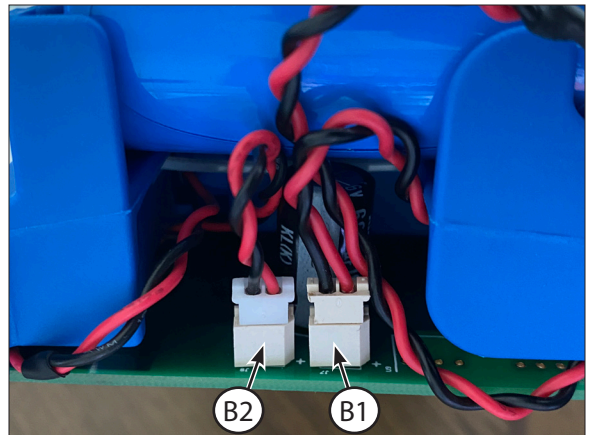

17. Set the hinged LCD/internal battery cover back in place to see the display. The unit will start to power up. Plug in all of the connectors to the board. Ensure that the unit is powered normally and there are no alarms.

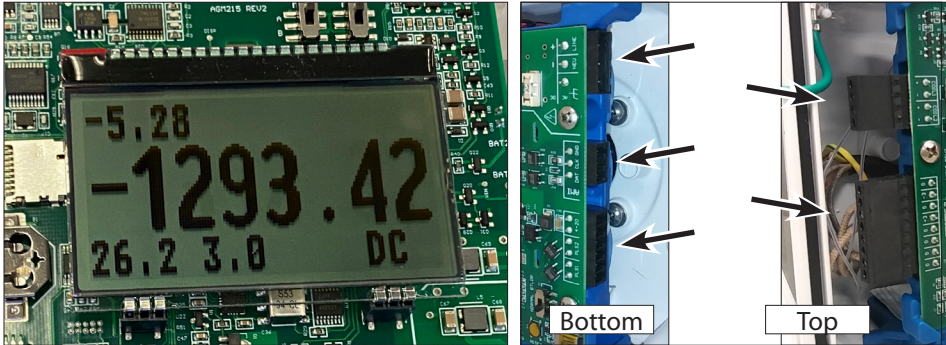

18. Replace the two screws that hold the LCD/battery cover in place.

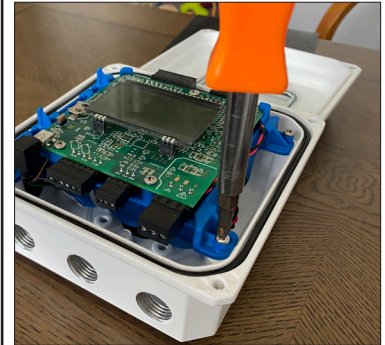

IV. Replacing the gasket

If you installed replacement batteries, we recommend that you replace the gasket.

If you installed new batteries, you must set the gasket in place before replacing the cover and closing up the unit.

19. If your unit has a gasket, remove it.

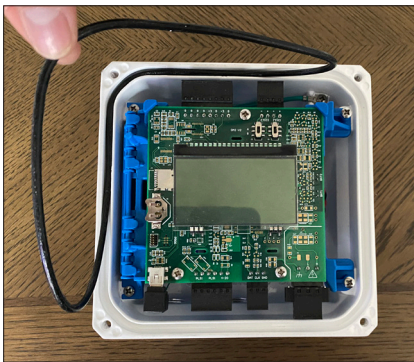

20. Apply a light coating of Molykote to the replacement gasket.

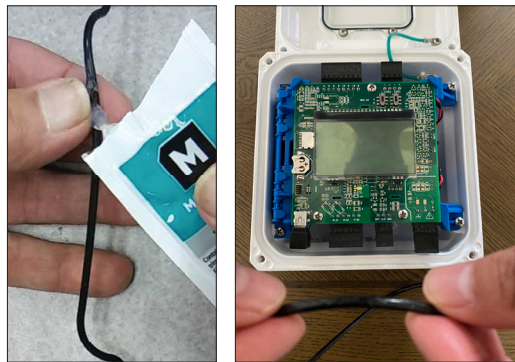

21. Place the gasket in the groove and press it in.

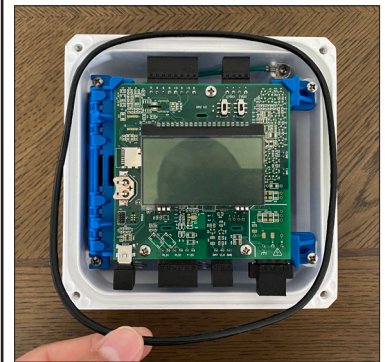

V. Replacing the cover

22. Place the converter lid onto the housing. Tighten the screws firmly. Be careful not to pinch any wires between the lid and the base.



23. Fasten the tamper proof seal as follows:
 a. Guide the wire through the hole in the screw.
 b. Thread the wire through the body of the tamper proof seal.

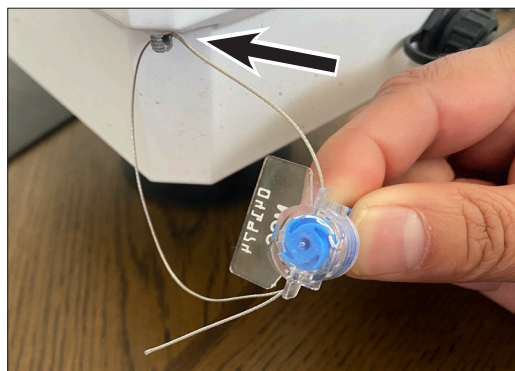

24. Rotate the blue part on the tamper proof seal to bring in the wire and secure the seal close to the screw.



8.0 OPERATION

8.1 General

The flow meter comes pre-configured from the factory based on the installation parameters provided to McCrometer at the time of order. Other than activating the display, there is nothing required of the user for the basic operation of the flow meter.

8.2 Activating the Display

The display is activated when the lid is opened. (Figure 28) The display will remain active for 30 seconds.

The various parts of the interface screen is shown below. (Figure 29) Depending on how the converter is configured with the configuration tool (see section 9.0) the display will show either single direction or bidirectional total flow quantities. Bidirectional flows are represented as either positive (POS) or negative (NEG), as shown at right.



Figure 28. Lift lid to activate display

I CAUTION: If the lid is broken off, contact the Factory for a lid replacement kit. In the meantime, set the lid on the meter in its proper position and use the boot to hold it in place.

NOTE The converter display is light activated and requires a minimum amount of light to appear. Environments where light is low, such as in dimly lit buildings or outdoors after sundown may prevent the display from appearing when the lid is raised.

There is an optical sensor embedded in the display located under the McCrometer “swirl” logo at the lower left. If the display does not appear, a flashlight will provide sufficient light to bring it up.

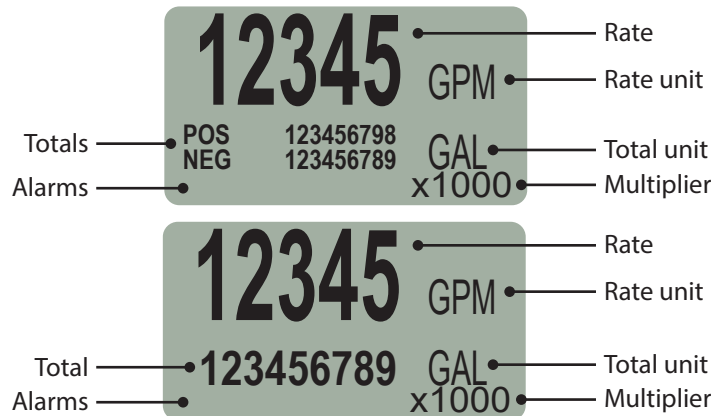

Figure 29. Interface screen, bidirectional and single direction flow

8.3 Converter Boot

The boot simply slips over the electronics enclosure. When installing the boot, insure the corners of the boot fit snugly over the lip of the enclosure. See Figure 30. To remove the boot, grip two corners and pull them away from the lip of the enclosure and then pull upwards. See Figure 31.

NOTE It is HIGHLY recommended that converter is covered by the boot at all times when the meter is not being read. The boot adds protection to the converter.

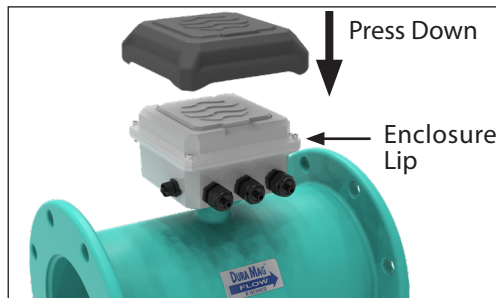

Figure 30. Boot installation

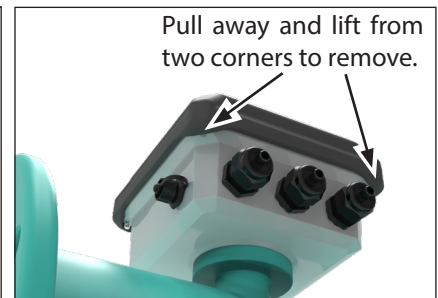

Figure 31. Boot removal

9.0 CONVERTER CONFIGURATION

The converter can be programmed to customize how the data is measured and stored. The configuration tool runs only on Windows 7, 8, or 10 and requires a computer with a USB port. You must have your flow meter's serial number before you begin. There are no installation files. The program and support files can be copied or unzipped into a folder and run from there.

This is only a summary of the configuration tool's functionality. The software has complete set-up and operation instructions included. The software can be downloaded from the McCrometer Web site.

Software Operation

1. Remove the cap that protects the USB port and plug in a mini-USB cable. (Figure 32) Connect the other end to a laptop computer.
2. Start the software. Follow the instructions shown before setting up your customized configuration. (Figure 33)
3. When you have set up your configuration file, you can change the settings listed below. Using the configuration tool is mostly self-explanatory.
 - Flow rate unit of measure
 - Totalizer unit of measure
 - Multiplier
 - Totalizer presets
 - Forward/reverse pulse enable: 1 pulse per x per unit of measure
 - Pipe ID
 - Clock time and date
 - Pulse output
 - Automated meter reading



Figure 32. Plug in mini-USB cable

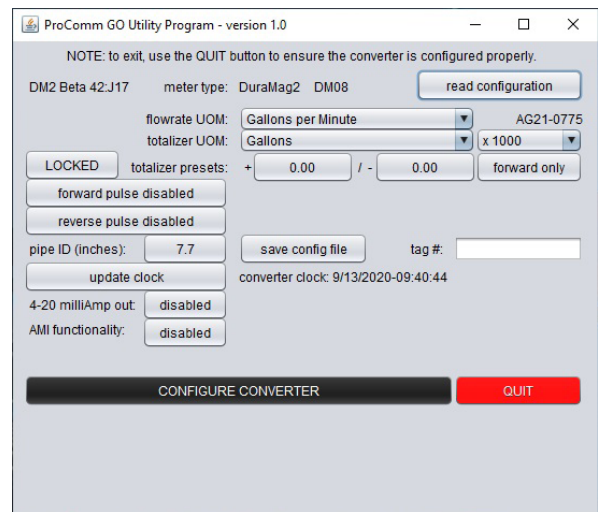

Figure 33. Configuration tool interface

10.0 ERROR MESSAGES FOR TROUBLESHOOTING

DISPLAY MESSAGE	Troubleshooting
BAT LOW	Battery replacement Kit is needed to replace batteries. The batteries Should last approximately 6-9 months from the time the warning is shown.
420 ERR	The 4-20 circuit is not wired correctly. Check the wiring diagram and ensure 9-30VDC power is supplied to the circuit. The output is not source powered.
COIL XCT	There is an issue with the electro magnetic coils. Check that the internal wiring is correct in the converter for the coil wires.
ADC CLIP	The meter signal exceeds the limit of the converter, likely due to noise. Check the meter grounding meets the IOM guidelines and identify any sources of noise.
HIGH HUM	Humidity inside converter housing has exceeded limits. Check for any loose connections on converter housing that could be creating a leak.
COIN LOW	Datalogger time backup battery is low. This is part of the battery replacement kit and should be replaced with the main battery packs.

11.0 SENSOR REMOVAL

**WARNING!**

The pipe may be under pressure. Serious injury or death may result if proper procedures are not followed. To remove the sensor follow the steps below:

1. Visually inspect the pipe and entire assembly for damage or corrosion paying close attention to any nipples and welded couplings. If there is any doubt as to the condition of any element of the pipe or sensor, depressurize the line before attempting a removal of the sensor.
2. Loosen the compression seal until the seal just begins to leak. This will relieve the pressure on the compression seal allowing the sensor to be removed. Draping a towel around the compression seal can reduce any spraying water. **NOTE:** The compression seal may prevent immediate leakage on sensors installed for a long period of time until the sensor begins to rise.
3. On the 1" sensor, rotate the captive nut on the top plate to raise the sensor.. On the 2" sensor rotate the captive nuts on the top plate simultaneously. The sensor insertion tool is recommended. See Section 4.8. This will cause the sensor to rise out of the pipe. If the line is under pressure do not remove the sensor from the compression seal completely. Only raise the sensor until it is clear of the valve, but still below the compression seal. Once the sensor has cleared the valve mechanism, the valve can then be closed. Do not attempt to force the valve closed while the sensor is still passing through the valve as permanent damage to the sensor can occur.
4. Once the valve is closed, the entire sensor can be removed from the valve.

12.0 MAINTENANCE

The SPI Mag is essentially a maintenance free meter with no user serviceable parts. However, the metered fluid may contain solids or other contaminants coat the sensor electrodes. A periodic inspection may be recommended to ensure the sensor electrodes are clean. To clean the unit remove the sensor following all of the instructions and safety warning contained in Section 5.0. When the sensor is removed from the pipe, carefully wipe down the sensor with a soft cloth and a mildly abrasive detergent, such as a liquid kitchen detergent.

13.0 SPECIFICATIONS

FLOW METER SPECIFICATIONS

Measurement	
	<ul style="list-style-type: none"> Volumetric flow in filled flow conduits 2" (50mm) to 96" (2,440 mm) diameter utilizing insertable velocity sensor. 1" meter = 2" to 30" pipe I.D.; 2" meter = 6" to 96" pipe I.D. Flow indication in English Standard or Metric units
Flow Measurement	
Method	Electromagnetic
Accuracy	+/- 2% of measured value ±0.03 ft/s (±0.009 m/s)
Velocity range	+0.3 to +32 ft/s (+0.09 to +10 m/s)
Direction measurement	Has reverse flow indication
Materials	
Sensor	Polyurethane exposed to flow
2" sensor mounting	PVC and Stainless Steel exposed to flow. (Stainless Steel Insertion Tube Optional)
Compression seal	Buna "N" O-Ring seal exposed to flow
Environmental Ranges	
Pressure/temperature limits	<ul style="list-style-type: none"> PVC Insertion Tube: Up to 105°F (41°C) at 150 PSI Stainless Steel Insertion Tube: Up to 160°F (71°C) at 250 PSI (McCrometer recommends the use of Stainless Steel) <p>Note regarding storage: During freezing conditions and when meter is not in use, sensor must be removed from pipe and stored in dry conditions.</p> <p>NOTE: Damage to the sensor caused by allowing the sensor freeze in the pipe is not covered by the warranty.</p>
Electrical Connections	
	Compression gland seals for 0.125" to 0.375" dia. round cable
Sensor Cable Lengths	
Standard	25' McCrometer supplied submersible cable with each remote mount unit.
Optional	Up to 200 feet, or 25 feet max for battery powered.
IP Rating	
	IP68 submersible sensor

FLOW METER SPECIFICATIONS (CONT.)

Insertion Tube

To determine insertion tube length for typical near wall installations, divide the pipe I.D. by 8 and add 18".

For full profiles, add 18" to the pipe I.D.

Tube assemblies include rods and mounting hardware

- | | |
|----------------|---|
| 1" tube | <ul style="list-style-type: none"> • Stainless steel tube, 12" length. Will profile 4" pipe I.D. • Stainless steel tube, 24" length. Will profile 16" pipe I.D. • Stainless steel tube, 36" length. Will profile 28" pipe I.D. |
| 2" tube | <ul style="list-style-type: none"> • PVC tube, 18" length. Will profile a 10" pipe I.D. • PVC tube, 24" length. Will profile a 16" pipe I.D. • PVC tube, 30" length. Will profile a 22" pipe I.D. • Opt.: stainless steel tube. Specify length - 240" maximum |

System Options

- Stainless Steel ID Tag
- Sensor Insertion Tool
- Additional Sensor Cable up to 200' (for longer lengths consult factory)
- Valves

Ordering Requirements

At the time of ordering, please be prepared to provide the following information:

- Model and tap size
- Insertion tube length
- Pressure
- Minimum flow
- Maximum flow
- Typical flow
- Fluid
- Pipe I.D.
- Cable length
- Temperature
- Any other chemicals in use
- Indicator and totalizer units

PROCOMM GO CONVERTER SPECIFICATIONS
Physical Specifications

Electronic Housing	Diecast aluminum, powder coated enclosure w/ tamper resistant seal, 6½" x 6½" x 43/8" tall
Converter Dimensions	See "Dimensions" section for meter mount and remote mount converter dimensions.
Power	Battery: Standard: three 3.6V lithium-thionyl chloride (Li-SOCl ₂) D size batteries with two AA backup batteries AC Power: 100-240VAC/45-66Hz (4W) DC Power: Linear power supply 10-35VDC (4 W)
Electrical Connections	<ul style="list-style-type: none"> • Optional shielded cable for 10-32VDC/4-20 mA output • Optional shielded cable for pulse out

Performance and Operational Specifications

Battery Life	Five-year expected battery life, five-year battery warranty
Location	Indoor or outdoor use
Altitude	Operating: 2000 meters Storage: 12,000 meters
Operating Temperature	-4° to 140° F (-20° to 60° C)
Storage Temperature	-4° to 140° F (-20° to 60° C)
Relative Humidity	0% to 100%
IP Rating	IP67 Die cast aluminum converter
Outputs	Digital output: Digital pulse (open collector) output for volumetric - Two isolated digital pulse (open collector) outputs for volumetric - AMI output Analog output: 4-20mA: Galvanically Isolated, 16 Bit resolution. All power configurations (including battery). Note: 9-30 VDC loop power required (not supplied via converter)

Display and Measurement

Display	<ul style="list-style-type: none"> • 2-Line LCD display (no backlight) • Non-volatile memory • Anti-reverse totalizer (standard) • Total (to 9 digits of precision) 	<ul style="list-style-type: none"> • Flow rate and velocity (to 5 digits of precision) • Two alarms: low battery and empty pipe (optional) • Opening lid activates display
Digits	5 Rate, 9 Total	
Units	GPM Gallons per minute IGM Imperial gal per minute CFM Cubic feet per minute MGD Mega gal per day MI9 Miners inch (9G) B5M Barrels per minute (55G) CFS Cubic feet per second MI1 Miners inch (11.22G) B5H Barrels per hour (55G) MLD Megaliters per day APD Acre feet per day B5D Barrels per day (55G) LPS Liters per second KLH Kiloliters per hour B4M Barrels per minute (42G) CMH Cubic meters per hour LPH Liters per hour B4H Barrels per hour (42G) LPM Liters per minute CMM Cubic meters per minute B4D Barrels per day (42G) GPH Gallons per hour CFM Cubic feet per minute	

Totalizer Units	GAL	Gallons	B42	Barrel (42G)	MH1	Miners Inch Hour (11.22G)
	CUF	Cubic Feet	B46	Barrel (46G)	MD1	Miners Inch Day (11.22G)
	AFT	Acre Feet	B55	Barrel (55G)	MH9	Miners Inch Hour (9G)
	CUM	Cubic Meters	IMG	Imperial Gallon	MD9	Miners Inch Day (9G)
	LIT	Liters	AIN	Acre Inch	KGL	Kilo Gallons
	MML	Megaliter	TON	Ton (Short)	MGL	Mega Gallons
	MTT	Metric Ton (KL)	MM1	Miners Inch Minute (11.22G)	IN3	Cubic Inch
	B31	Barrel (31G)	MM9	Miners Inch Minute (9G)		
	Data Logger	Standard with all models, minimum of five years of data stored				

Other Specifications

Options and Accessories

- Data Logger - included as standard with five years of data storage at default (12hr) interval. (Cable sold separately)
- AC, DC, and battery powered with battery backup powered available

Safety

- IEC 61010-1, Pollution Degree II
- Overvoltage protection Category III

Certifications

Standard Model

- ISO 9001:2015 certified quality management system
- Certified by MET to UL 61010-1 / CSA C22.2 No. 61010-1

HL Model

- ISO 9001:2015 certified quality management system
- Certified by MET: Safety: UL61010-1 / CSA C22.2 No. 61010-1, Third Edition: Safety of Electrical Equipment For Measurement, Control, and Laboratory Use
- Certified by MET: Standards: ANSI / ISA12.12.01 / CSA C22.2 No. 213, Nonincendive Electrical Equipment
 - Class I and II, Division 2
 - Class III, Divisions 1 and 2 Hazardous (Classified) Locations



14.0 SPI MAG ORDERING INFORMATION

The standard SPI Mag includes:

- SPI Mag sensor
- ProComm converter
- 25-foot sensor cable
- Installation and Operation Manual

Options

- Extended sensor cable (up to 200', for longer lengths, consult factory)
- Sensor insertion tool - Part No. 75031
- Additional Installation and Operation manuals - Part No. 24511-13
- RS485 Port

Returning a unit for repair

If the unit needs to be returned to the factory for repair, please do the following:

- Prior to calling for a return authorization number, determine the model number, serial number (located inside the front panel of converter), and reason for return.
- Contact McCrometer Customer Service Department and ask for a Return Authorization (RA) number.
 - Telephone: 1-800-220-2279
 - Email: customerservice@mccrometer.com
- Ship the meter in the original packaging, if possible. Do not ship manuals, power cords, or other parts with your unit unless required for repair.
- Please make sure the meter is clean and free from foreign debris prior to shipping.
- Write the RA number on the outside of the shipping box. All return shipments should be insured.
- Address all shipments to:

McCrometer, Inc.
RA#
3255 W. Stetson Ave
Hemet, CA 92545

15.0 CONVERSION TABLES
Table of Decimal Equivalents

Fraction	Decimal
1/8	.125
1/4	.25
3/8	.375
1/2	.5
5/8	.625
3/4	.75
7/8	.875

Table of Conversions

Multiply	By	To Get
Centimeters	0.3937	Inches
Centimeters	0.03281	Feet
Inches	25.4	Millimeters
Feet	30.48	Centimeters
Square Feet	144.0	Square Inches
Square Inches	0.006944	Square Feet
Cubic Inches	0.0005787	Cubic Feet
Cubic Feet	7.481	Gallons
Cubic Feet	1728.0	Cubic Inches
Cubic Feet	0.02832	Cubic Meters
Cubic Feet	28.32	Liters
Cubic Meters	35.31	Cubic Feet
Cubic Meters	264.2	Gallons
US Gallons	3.785	Liters
US Gallons	0.1337	Cubic Feet
US Gallons	0.003785	Cubic Meters
US Gallons	.8326748	Imperial Gallons
Liters	0.2642	Gallons
$^{\circ}\text{F} = (^{\circ}\text{C} \times 9/5) + 32$	$^{\circ}\text{C} = (^{\circ}\text{F} - 32) \times 5/9$	

WARRANTY

McCrometer warrants that this product will be free from defects in material and workmanship for a period 24 months from the date the equipment was first installed, but in no event longer than 30 months from the date the equipment was first shipped by McCrometer. Repairs shall be warranted for 12 months or, if the repair is performed under this warranty, for the remainder of the original warranty period, whichever is less.

Buyer shall report any claimed defect in writing to McCrometer immediately upon discovery and in any event, within the warranty period. McCrometer shall, at its sole option, repair the equipment or furnish replacement equipment or parts thereof, at the original delivery point.

McCrometer shall not be liable for costs of removal, reinstallation, or gaining access. If Buyer or others repair, replace, or adjust equipment or parts without McCrometer prior written approval, McCrometer is relieved of any further obligation to Buyer under this Article with respect to such equipment.

No equipment furnished by McCrometer shall be deemed to be defective by reason of normal wear and tear, failure to resist erosive or corrosive action of any fluid or gas (unless otherwise specified in Quotations/ Purchase Order Specifications), Buyer's direct or indirect failure (or the failure of its agents or contractors) to properly store, install, operate, or maintain the equipment in accordance with good industry practices or specific recommendations of McCrometer, or Buyer's failure to provide complete and accurate information to McCrometer concerning the operational application of the equipment.

THE FOREGOING LIMITED WARRANTIES WITH RESPECT TO EQUIPMENT AND PRODUCTS ARE EXCLUSIVE AND IN LIEU OF ANY AND ALL OTHER WARRANTIES OF QUALITY OR PERFORMANCE, EXPRESS, IMPLIED OR STATUTORY, INCLUDING, WITHOUT LIMITATION, ANY AND ALL WARRANTIES OF MERCHANTABILITY OR FITNESS OF SAID EQUIPMENT AND PRODUCTS FOR ANY PARTICULAR PURPOSE.

MCCROMETER DISCLAIMS ANY WARRANTY, WHETHER EXPRESS OR IMPLIED, REGARDING THE SUITABILITY OF PRODUCTS AND EQUIPMENT SUPPLIED PURSUANT TO ANY PURCHASE ORDER FOR INSTALLATION IN ANY PARTICULAR SYSTEM OF SYSTEMS. MCCROMETER MAKES NO WARRANTY OF ANY KIND WITH RESPECT TO ANY SERVICES PERFORMED BY MCCROMETER OR ITS AGENTS PURSUANT TO ANY QUOTATION.

Purchaser's sole remedy and manufacturer's sole obligation for alleged product failure, whether under warranty claim or otherwise, shall be the aforesaid obligation of manufacturer to repair or replace products returned within twenty-four months after date of original shipment. The manufacturer shall not be liable for, and the purchaser assumes and agrees to indemnify and save harmless the manufacturer in respect to, any loss or damage that may arise through the use by the purchaser of any of the manufacturer's products.

McCrometer does not authorize any person or entity (including, without limitation, McCrometer agents and employees) to make any representations (verbal or written) contrary to the terms of this limited warranty or its exclusions. Such terms of this limited warranty and its exclusions can only be effectively modified in writing and only by the President of McCrometer.

OTHER McCROMETER PRODUCTS INCLUDE:

Propeller Flow Meters



Differential Pressure Flow Meters



Magnetic Flow Meters



Connected Solutions



Copyright © 2021 McCrometer, Inc. All printed material should not be changed or altered without permission of McCrometer. Any published pricing, technical data, and instructions are subject to change without notice. Contact your McCrometer representative for current pricing, technical data, and instructions.

3255 WEST STETSON AVENUE • HEMET, CALIFORNIA 92545 USA
TEL: 951-652-6811 • 800-220-2279 • FAX: 951-652-3078
www.mccrometer.com

