

ILF KOMMUNAL 143HP



ENERGREEN[®] *America*

Professional Machines



SELF-PROPELLED
HYDROSTATIC
MACHINES



ILF SELF-PROPELLED

SELF-PROPELLED
HYDROSTATIC MACHINES

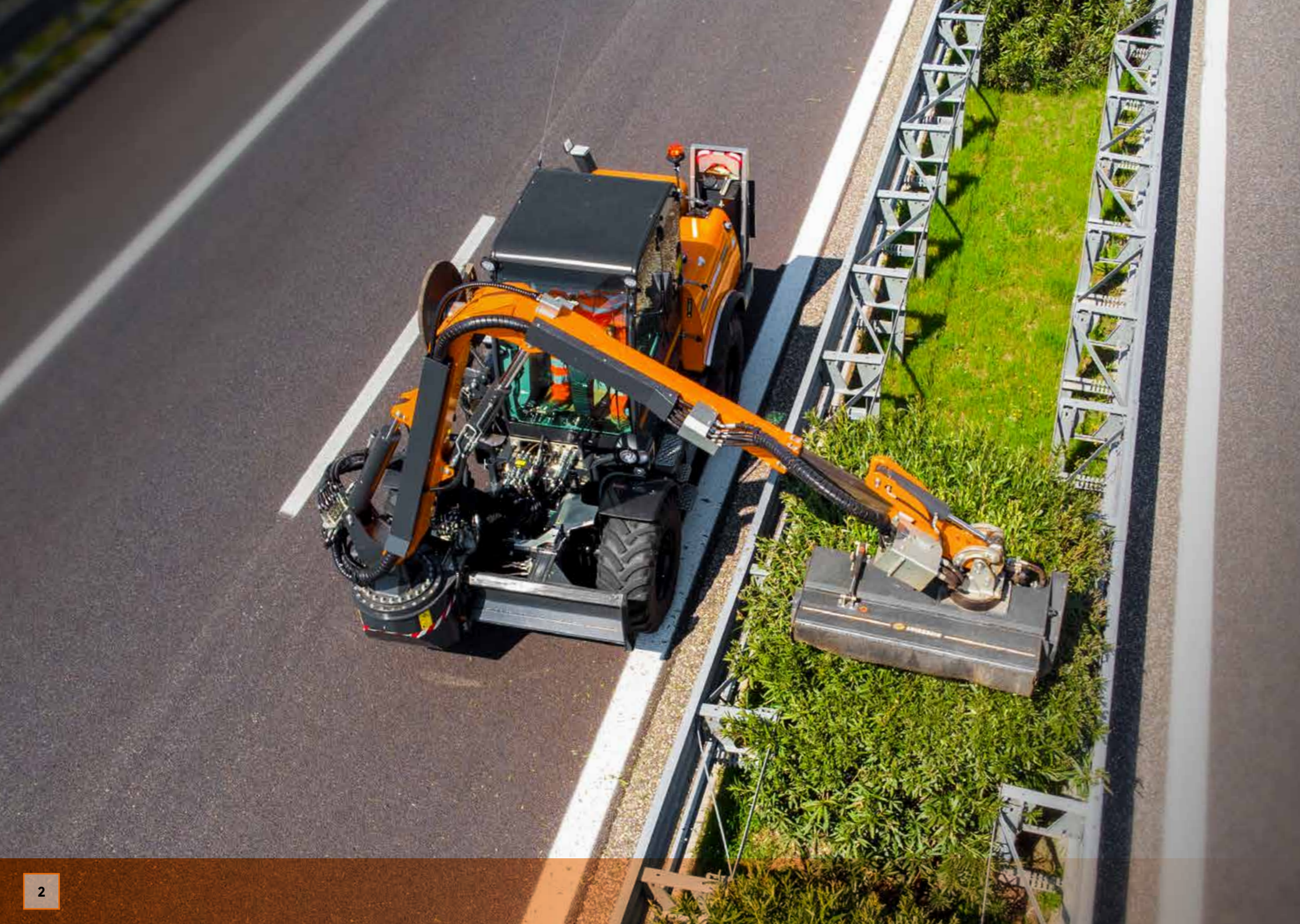

BRUSHCUTTER

The Essential Multifunction Hydrostatic Machine

ILF **Kommunal** is a multifunction self-propelled tool-carrier equipped with a front quick coupling system that allows the installation of multiple attachments for management of vegetation, construction work and multi-season street maintenance.

Thanks to the fixed cabin and the front-mounted attachment, the operator can enjoy maximum visibility and comfort while working. In addition to the tool setted on the front side, it is possible to arrange different configurations to manage attachments also on the back side.

This self-propelled machine is equipped with the latest generation **Deutz engine** that provides **143 HP** in compliance with the **EPA Tier 4f** anti-pollution regulations.

ILF *KOMMUNAL*



STRENGTHS

ILF KOMMUNAL



STRENGTHS



Safety and Comfort

- FOPS-ROPS certified cabin
- High visibility panoramic windshield
- Excellent working ergonomics
- Stability Control Device



Quality

- Deutz 143 HP powerful engine
- EPA Tier 4f emission
- Heavy Duty hydrostatic transmission
- Main parts made with special steel



Multifunction

- Several tools available
- Green maintenance and forestry work
- Winter viability
- Construction work



Productivity

- Quick Connection System for the attachment
- More tools applicable at the same time
- Maximum maneuverability on all fields
- Maximum 360° visibility



MULTIFUNCTION

Multipurpose Machine for countless applications

ILF **Kommunal** is the ideal multifunction machine for those who daily have to face several kinds of job. Equipped with a quick attachment front system, this self-propelled machine can be quickly set up with several tools for green maintenance, construction sites work, all-season road services. Moreover, it is possible to arrange different configurations for the setting up of attachments on the back side.



360° VISIBILITY



GREAT VISIBILITY OF THE WHEEL



Total view of the Working Environment

When getting inside the ILF **Kommunal** the first surprising feature is the large windshield that offers a maximum 360° visibility for the full control of the working environment.

The adjustable steering wheel, comfortable seat and intuitive and ergonomic operation established immediately, a strong feeling between the operator and the machine, that, thanks to its equipment makes even the most tough working day much easier.



CABIN COMFORT



FOPS-ROPS
CERTIFIED

Maximum Safety and Comfort

ILF **Kommunal** cabin is certified according to the FOPS-ROPS regulation that guarantees the protection against overturning and objects fall.

The cabin is completely isolated and efficiently air-conditioned thanks to a sealing system: soft gasket are set on fixed and mobile glasses and the cabin is installed on elastic supports on sustain points. In this way, this multifunction machine is suited for working in dusty and noisy environments for many hours per day, still keeping a high level of comfort.

The cabin is available in three versions:
STANDARD - COMFORT - PRESTIGE



CABIN STANDARD

- FOPS-ROPS certified.
- Tilting and adjustable steering wheel.
- On-board computer for diesel engine control.
- Tilting and height-adjustable steering column.
- Adjustable air suspension seat.
- Electric reverser of the machine direction.
- Air conditioning system.
- Anti-pollen air conditioning filter.
- Adjustable armrest with joystick.
- Rear windows darked anti u.v.
- Front windscreen wiper.
- Rotating LED lamp.
- Divisible cabin door 60/40.
- Rear glove box.
- Internal courtesy light.
- External electrical socket 12 volt.
- Side pocket.
- Document holder.
- Cigarette lighter.
- Left rear-view mirror.
- Coat hanger.



CABIN COMFORT

In addition to the installation of the cabine "STANDARD"

- Cruise Control.
- Instant reverse pedal.
- Radio with Bluetooth/DAB.
- Retractable sunshade on front windshield.
- LED working lights.
- GRAMMER MAXIMO XXL seat with air suspension and adjustable lumbar shock absorber



CABIN PRESTIGE

In addition to the installation of the cabine "COMFORT"

- Monitor screen with 1 camera.
- Second flashing lights.
- Porthole with grille, curtain and windscreen wiper.
- Windshield wiper on the right side.
- Fire extinguisher.
- GRAMMER MAXIMO EVOLUTION DYNAMIC seat with larger seat dimensions, air suspension system, longitudinal shock absorber, side suspension, lumbar shock absorber and active climate control system



ADJUSTABLE STEERING WHEEL



MONITOR SCREEN WITH CAMERA



TOP PORTHOLE WITH GRILLE

CABIN STANDARD

CABIN PRESTIGE

CABIN PRESTIGE

MULTIFUNCTION

MACHINE

Multifunction Machine

The idea at the base of ILF **Kommunal** project is the extreme level of configuration. Hook and release quick system for the attachment allow a fast re-configuration of the machine, for switching from one kind of job to a completely different one, with a significant cost reduction. Moreover, upon request, it is possible to easily adapt third parts attachments.



EXTREME CUSTOMIZATION



A FRONT APPLICATIONS

- Boom
- Front loader
- Front lifter
- Multipurpose bucket
- Concrete mixer bucket
- Pallet forks
- Snow blade
- Snow plow
- Snow blower
- Guardrail mower
- Mower
- Sweeper

B REAR APPLICATION

- Blower
- Salt spreader
- Tow hook

C LATERAL APPLICATION

- Shrek - barrier mowing disc

QUICK ATTACHMENT



EASY AND FAST FRONT ATTACHMENT

The exclusive Energreen quick change design for ILF **Kommunal** has been inspired by the opportunity for a single operator to hook the attachment in complete autonomy. The system is smart: align the machine with the attachment, insert the guides, block the unit through the hydraulic hook device, connect

all hydraulic circuits with only one plate... and now you are ready to experience the maximum work performance! The hydraulic couplings interface is composed by a unique connection plate equipped with an exhaust system that drains the residual pressure in order to make the lock/unlock system much easier.

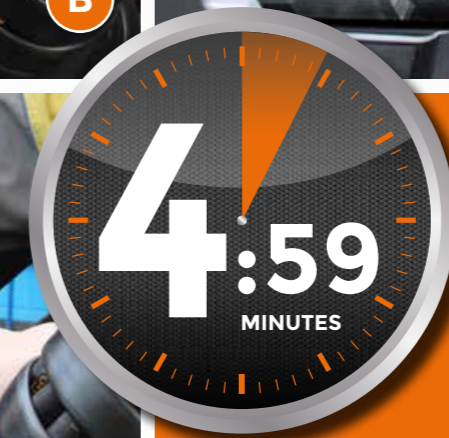
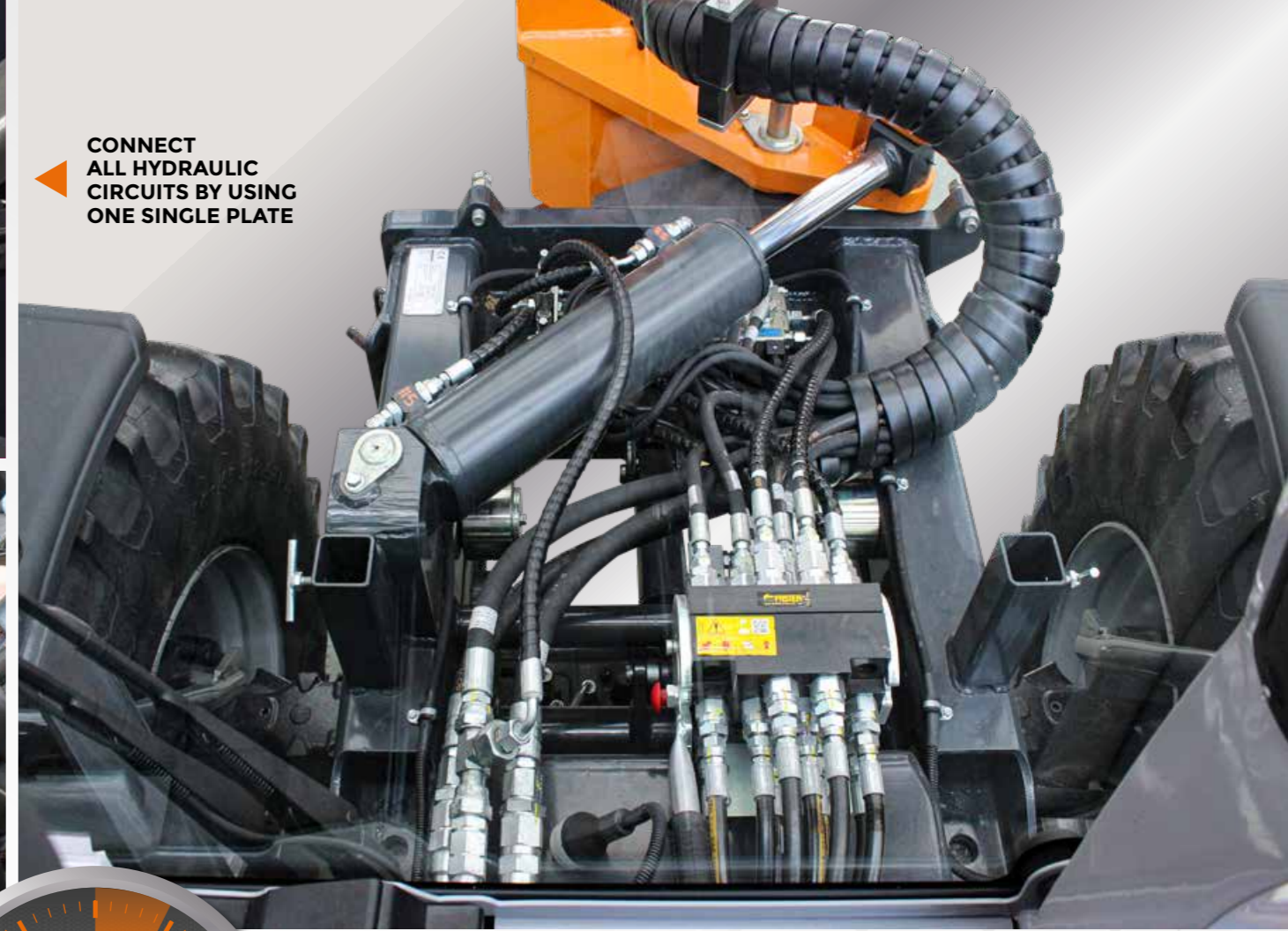
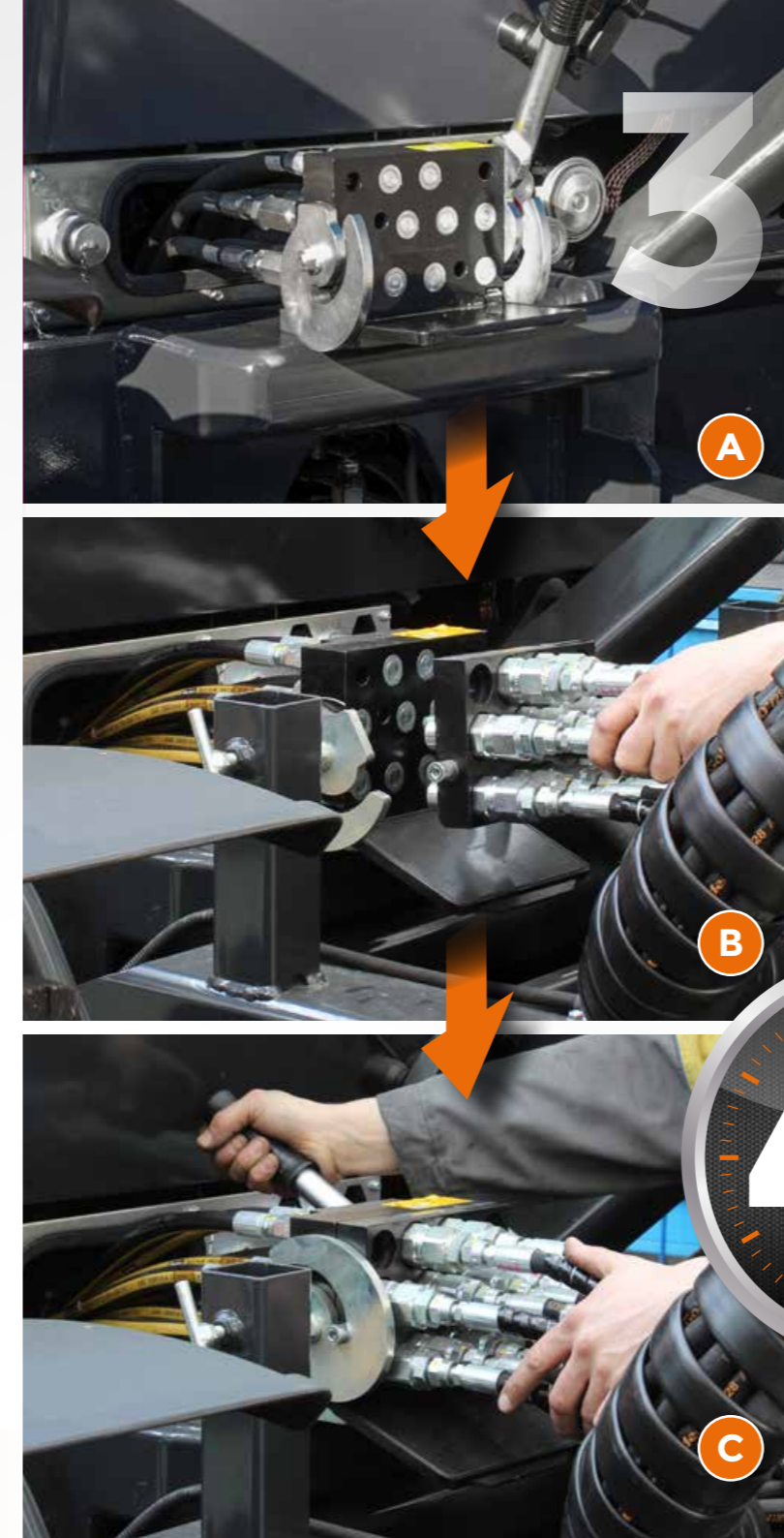

IN 4:59 MINUTES... YOU'RE READY FOR THE MAXIMUM OPERATIVITY!

GO!



CONNECT

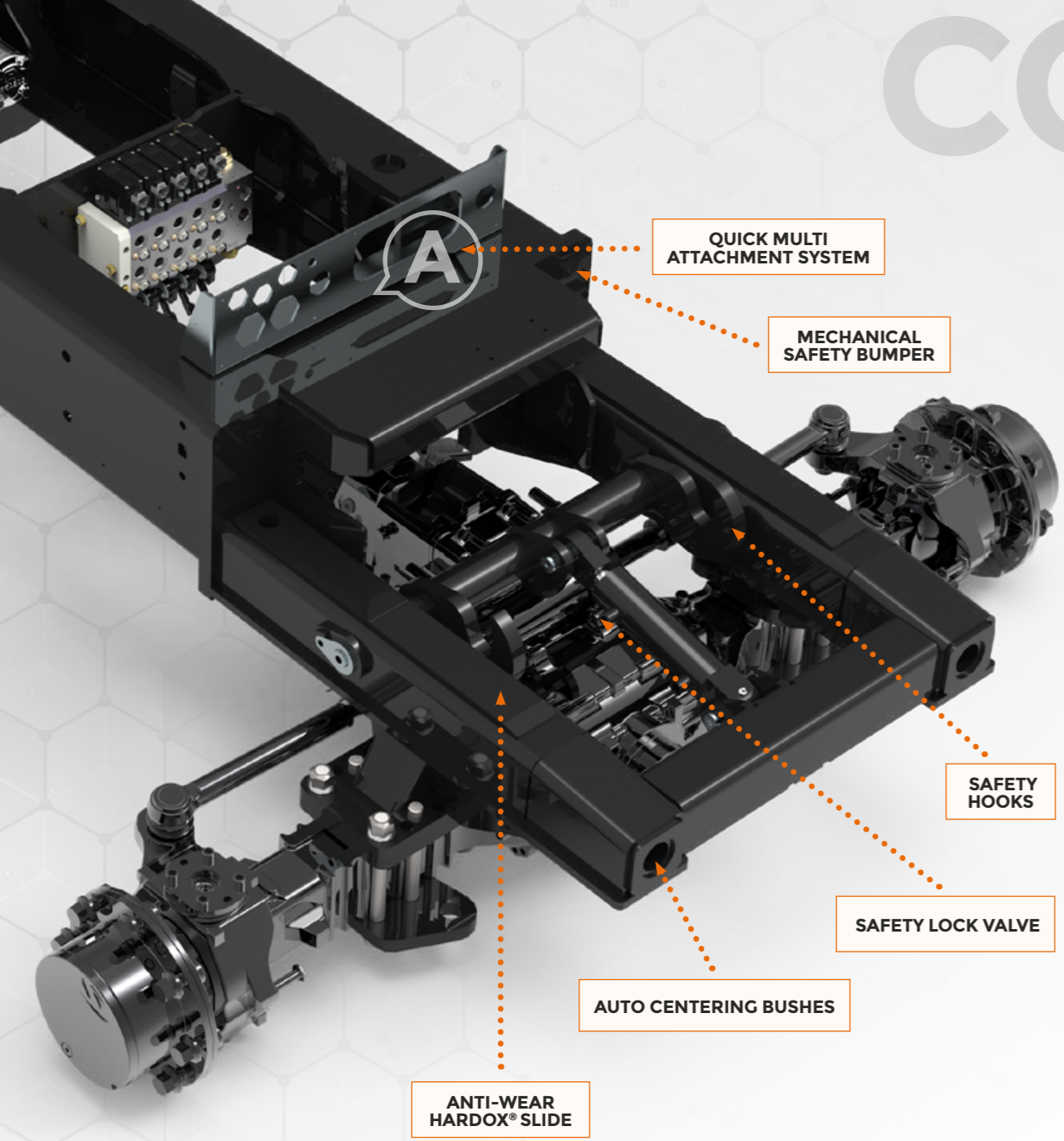

CONNECT Quick Attachment System

The exclusive quick attachment **CONNECT** system of ILF **Kommunal** allows the operator to set the attachments on the front side in a easy and fast way, while sitting in the cabin. It is composed with two ultra-resistant Hardox® slides, integrated into the frame through two bushing for the self-centering of the attachment and with a piston lock valve that allows to lock the two safety hooks.



FRONT QUICK ATTACHMENT



MULTI-CONNECTION PLATE **A**





Naturally Green

Energreen is a specialist in design and construction of machines and attachments for green maintenance and it has naturally used its experience in this multifunction self-propelled machine. Indeed, ILF **Kommunal** is incomparable when talking about green maintenance along routes and in others activity connected to the public green: grass cutting on roads edge, deforestation and also construction work. Together with specific and reliable professional attachments it is the ideal, economic and time-saver solution for all the needs related to roadways.



COMPACT 6.5^{21'} COMPACT 7.2^{24'}

A1



COMPACT BOOM

The main feature of the **COMPACT** boom is the adjustable geometry parallelogram. This one allows to reduce the total size of the boom, cancelling the dead zones on the road edges (in height too) and it also allows to extend lengthwise the tool in only one move. This movement is perfect when pruning the tops of hedges.

** Variable dimensions depending on the attachment*

MOD.	A	B	C	D	E	F
6.5	15'	22'	28'	8'	5'	11'
7.2	17'	24'	29'	8'	5'	11'

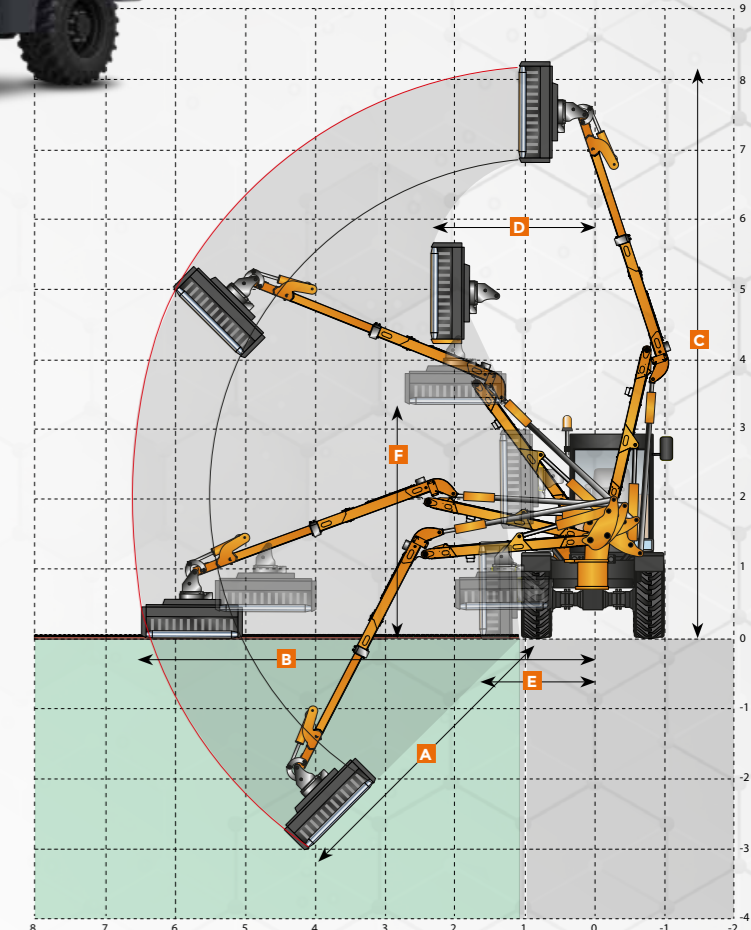

Technical and construction specifications may be subject to changes without prior notice.



A1

The **FAST** telescopic boom has been designed to work with an extension up to 29 ft and to reach a maximum height of 33 ft. Its particular geometry enhances the characteristics for road maintenance where it is required a combination of mowing along the roadside and a final work of deep trimming. The sturdy telescopic extension** allows great work flexibility and maximum performance even in difficult situations.

** Fast 7 / Fast 9

MOD.	A	B	C	D	E	F
FAST 6	11,5'	19,6'	24'	10'	5,2'	10,5'
FAST 7	15,5'	23'	27,6'	10,3'	5,4'	10,6'
FAST 9	22,4'	29'	33'	11'	6'	10,7'

All dimensions are to be considered with a 120 cm NEW SPEED flail head in the most extreme fixing position.

FAST BOOM

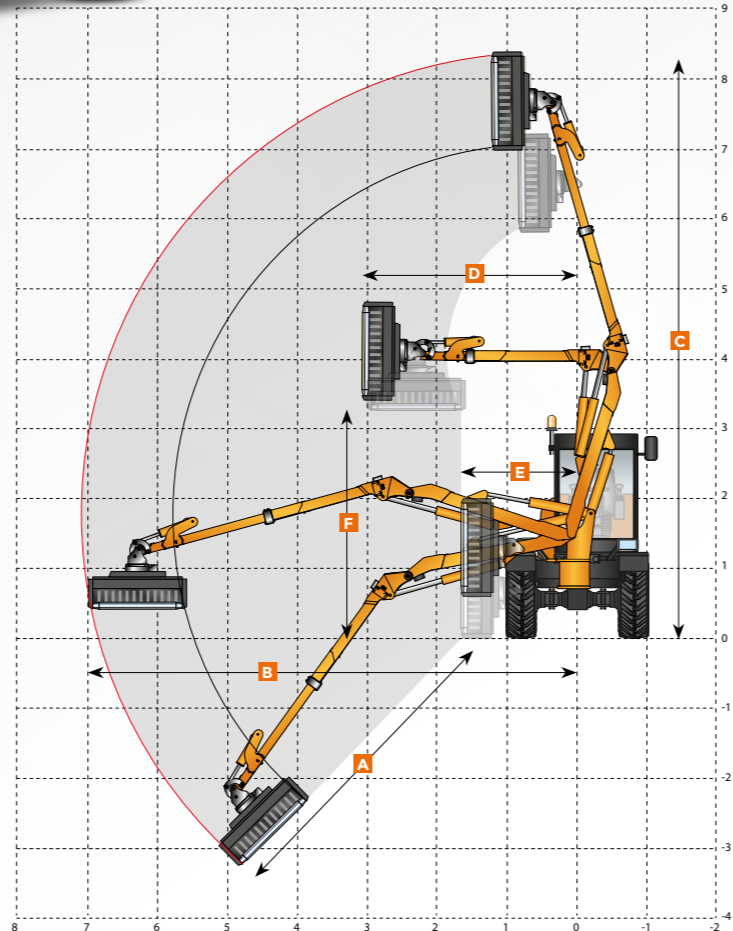

Technical and construction specifications may be subject to change without prior notice.



290° ROTATING UNIT HYDRAULIC SIDE-SHIFT

ORBITAL 8 26'



A1

ORBITAL 8 is a sturdy telescopic boom designed to work on both sides of the street while maintaining minimum size on the road. This is possible thanks to a 290° rotating unit and to a hydraulic sideshift that allows the boom to make a horizontal movement from right to left and vice versa.

ORBITAL BOOM

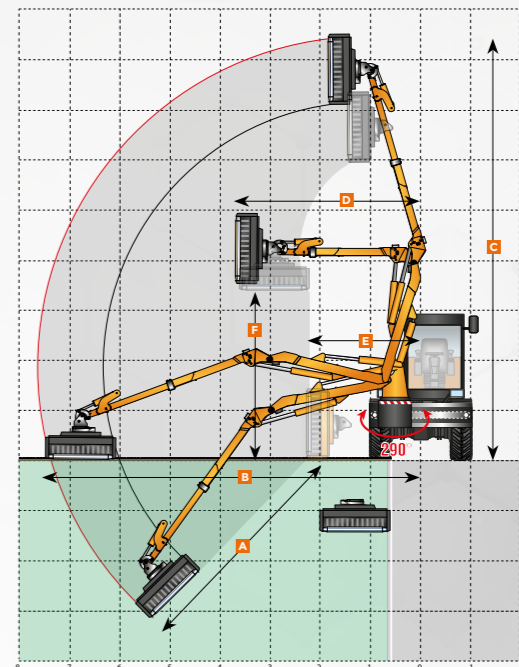

WORK WITH RIGHT BOOM

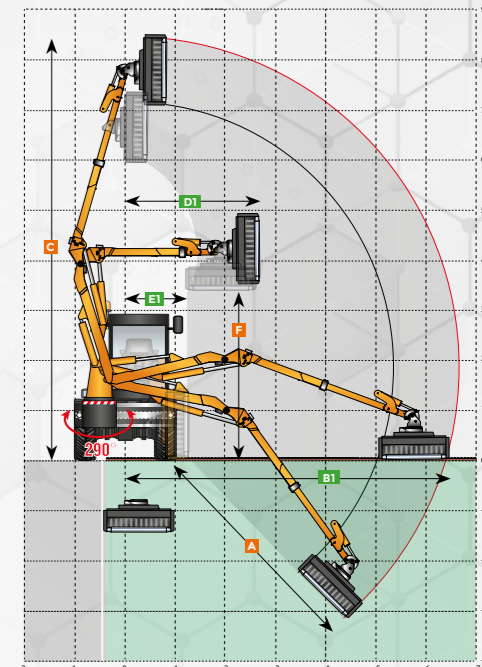

WORK WITH LEFT BOOM

A	B	C	D	E	F	B1	D1	E1
17,4'	24,6'	27,5'	11,8'	7,2'	10,5'	21,3'	8,5'	4'

All dimensions are to be considered with a 120 cm NEW SPEED flail head in the most extreme fixing position.

Technical and construction specifications may be subject to change without prior notice.

 **ATTACHMENT**

THE SUITABLE TOOL FOR EVERY JOB



NEW SPEED



FORESTRY HEAD



SAW BAR



CUTTER BAR



POWER SHEARS



STUMP GRINDER



EXTRA TRUNK



ORANGE PEEL GRAPPLE



TRUNK PINCERS



FORC-ONE



DITCH CLEANER



IRON BRUSH

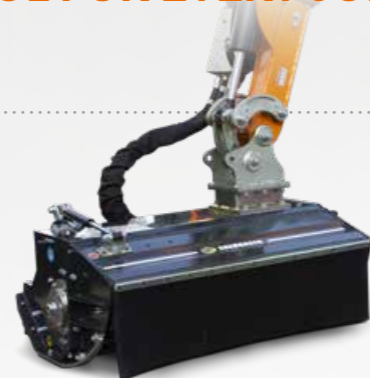

NEW SPEED
47" and 59"
FLAIL HEAD

Special steel frame - Standard frontal hydraulic opening
Adjustable roller - Five types of rotor shaft
Engine 35 cc - Cutting diameter 3 1/2" max.
(Hydraulic opening is removable)



RAIBER DISCOVERY 840
BARRIER MOWER



ROTATOR UNIT
ROTATOR UNIT FOR 180° ATTACHMENT ROTATION



SHREK
LATERAL MOWING DISC FOR BARRIER MOWER



CONSTRUCTION WORK

The Best option for Construction Work!

Energreen ILF **Kommunal** can be considered as a construction work machine, for excavation and earthmoving activity, able to respond quickly and completely to the frequent restoration or maintenance works that a municipal authority normally has to face.

Thanks to the front loader equipped with hydraulic quick change and various tools equipped also with quick couplings, the machine becomes extremely multifunctional and able to perform multiple jobs even in the construction sector such as earthmoving, transport of goods on pallet, sweeper, etc.



CUSTOMIZATION

A3

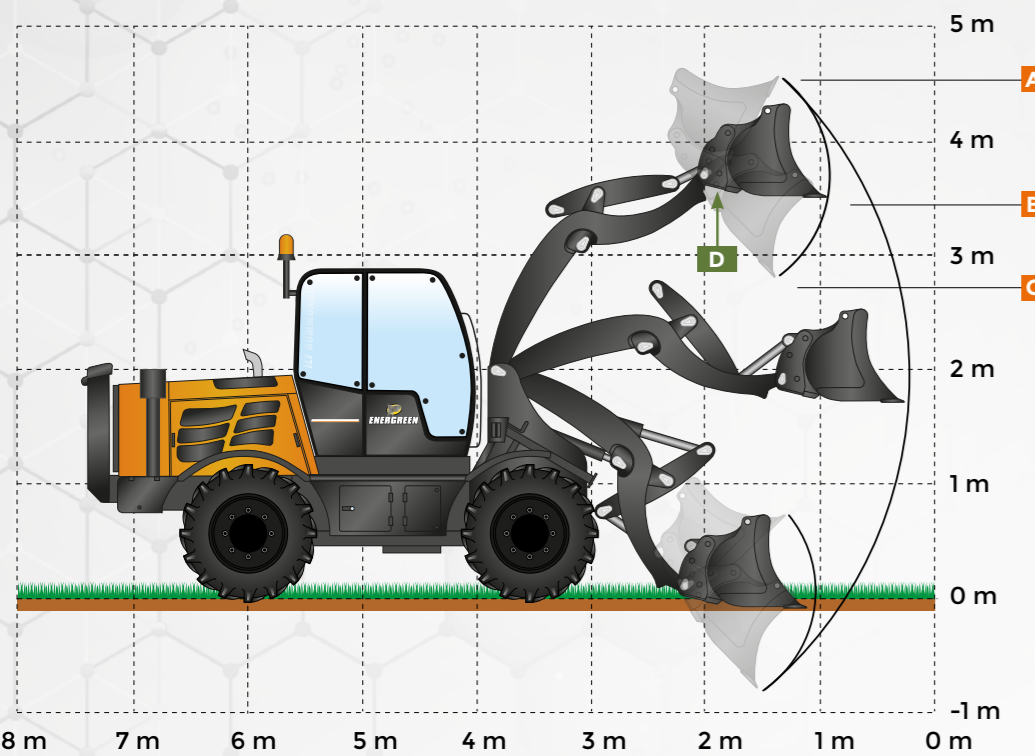

FRONT LOADER

FRONT LOADER with quick coupling. It is equipped with hydraulic quick release for the attachment: bucket, mixer bucket, forks. Maximum reliability and lifting power up to 13 ft high.

A	B	C	D	ft ³
15'	11'	9'	Load that can be lifted	Bucket volume
			3527 lbs	7,06 ft ³



STANDARD BUCKET



BUCKET MOD. 4X1



BUCKET MIXER



FORKLIFT ATTACHMENT

Technical and construction specifications may be subject to change without prior notice.

CUSTOMIZATION

A4



LINKAGE "HERCULES"

The **HERCULES** 3-point hitch with PTO front connection makes the ILF **Kommunal** a highly efficient machine in any kind of situation considering the possibility to install a wide range of commercial accessories by controlling them directly from the cabin, with full and direct control of all working operations.

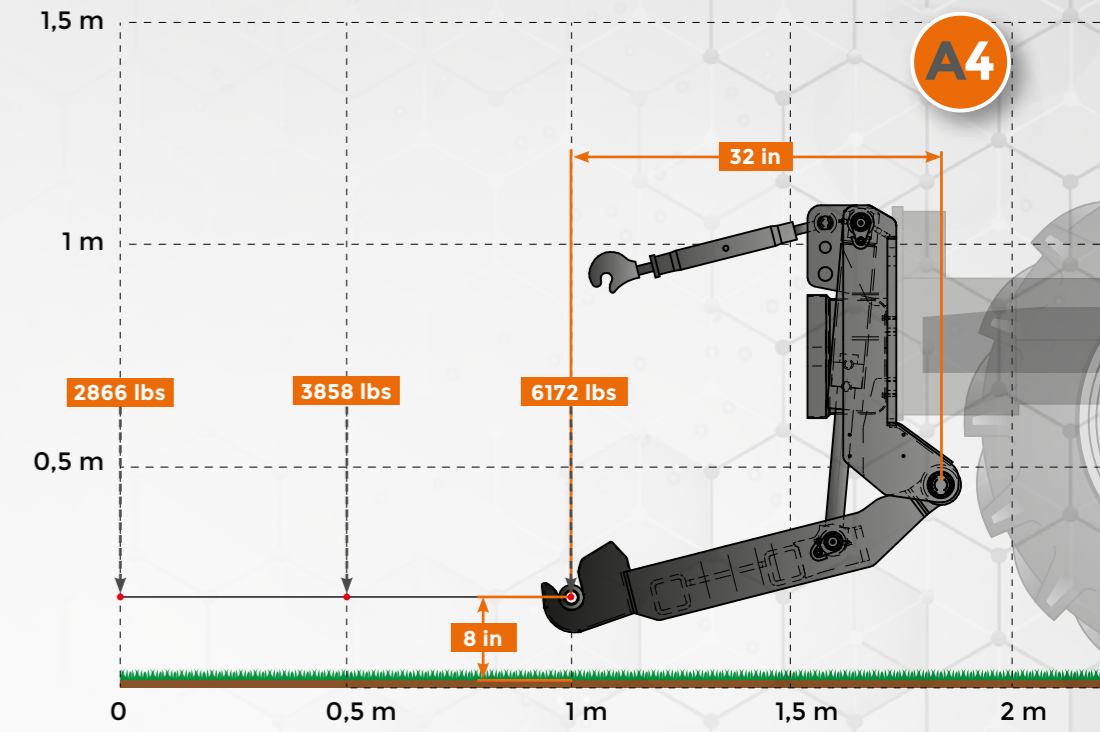

Technical and construction specifications may be subject to change without prior notice.



FRONT SHREDDER



SIDE SNOW BLOWER





WINTER ROAD SERVICE

The solution for winter problems

The wide range of winter accessories that can be installed on the ILF **Kommunal** makes the machine particularly efficient both for salt spreading activity and for the removal of the snow-covered roadway.

RELIABILITY IN EVERY CRITICAL SITUATION



**SPARGISALE
SALT SPREADER**



**LAMA DA NEVE A SETTORE UNICO
SNOW BLADE WITH ONE SECTION**



**VOMERE SGOMBRANEVE
SNOW PLOW**



**FRESANEVE
SNOW BLOWER**



**FRESA LATERALE
SNOW BLOWER SIDE**

ENGINE

ILF KOMMUNAL



DEUTZ Power Engine

ILF Kommunal is equipped with a 143 HP 4-cylinder inline engine with liquid-cooled, external exhaust gas recirculation and EPA Tier 4f emissions.

The powerful Common Rail injection system at high pressure and the electronic engine control (EMR) with intelligent link to the drive management ensure optimum engine performance at low fuel consumption.

- Minimum consumption of operative liquids compared to competitors.
- Technical support and diagnosis provided by DEUTZ's worldwide service network.

DEUTZ TCD 3.6



EASY ACCESS
FOR MAINTENANCE



ENGINE



ON-BOARD COMPUTER FOR DEUTZ
DIESEL ENGINE CONTROL

AGILITY

Agility and Accuracy in the Movements

The multifunction soul of this machine is highlighted also from the 4-wheel drive traction system, all steering, hydraulically configurable from the cab control in 3 different operating modes:

- **2 front steering wheels**, for the maximum agility on road movement.
- **4 steering wheels**, a system that halves the turning range of the machine, ideal for working in narrow areas.
- **4 parallel steering wheels (crab)**, useful for moving special tools or for moving away from an obstacle.



RADIUS
7' 5"

2 STEERING WHEELS



4 STEERING WHEELS CONCENTRIC



4 STEERING WHEELS PARALLEL



STABILITY

Stability Control Device

The **Stability Control Device** allows to lock the rear axle shift, increasing the stability of the machine, in order to guarantee the maximum level of performance and safety for the operator. This plus is given by two hydraulic jacks fixed on the chassis of the machine and controlled by the operator inside the cab.

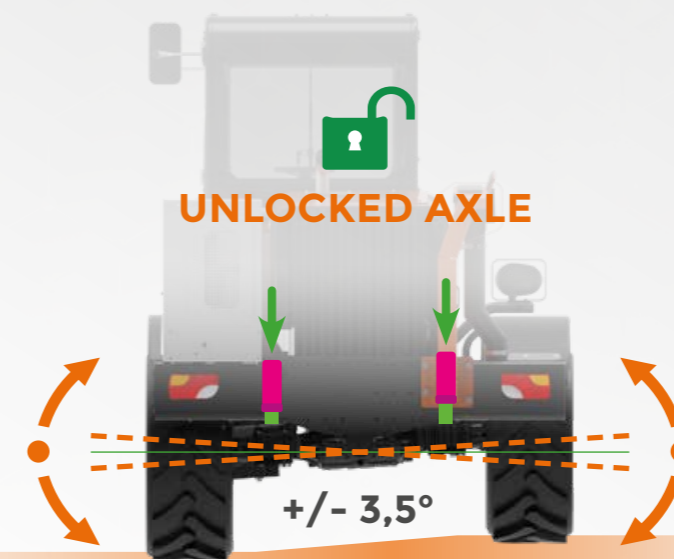

UNLOCKED AXLE

+/- 3,5°

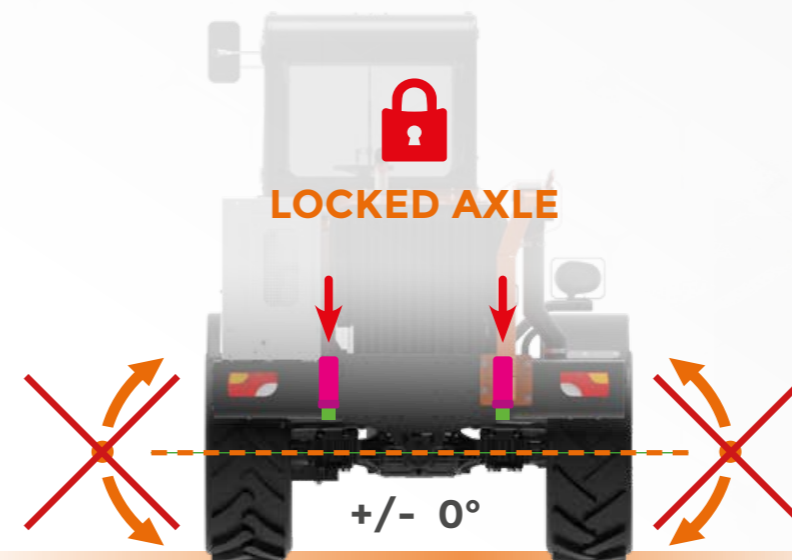

LOCKED AXLE

+/- 0°

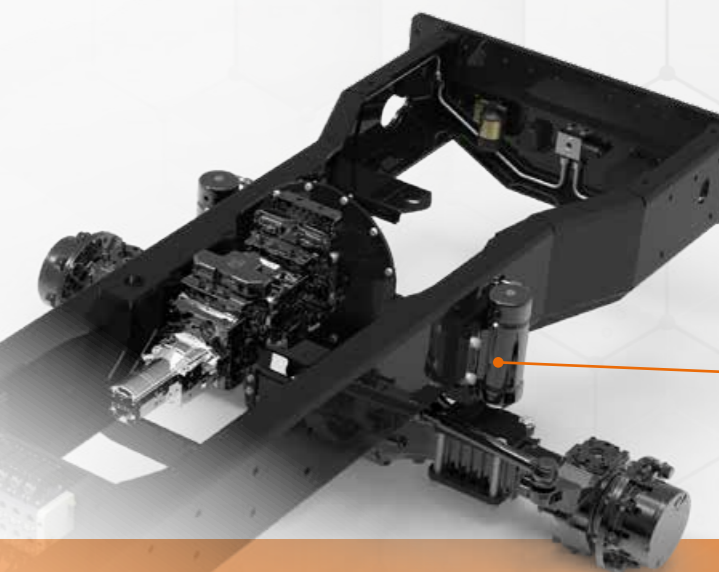

JACK FOR OSCILLATION CONTROL



QUALITY

FIVE INDEPENDENT HYDRAULIC SYSTEMS:
1. MOVEMENT 2. CUTTING HEAD 3. STEERING 4. BRAKING 5. BOOM FUNCTIONS

INLET HIGH PRESSURE FILTER TO THE DISTRIBUTOR

4 WHEEL DRIVE

FIXED FRONT AXLE

HYDROSTATIC TRANSMISSION

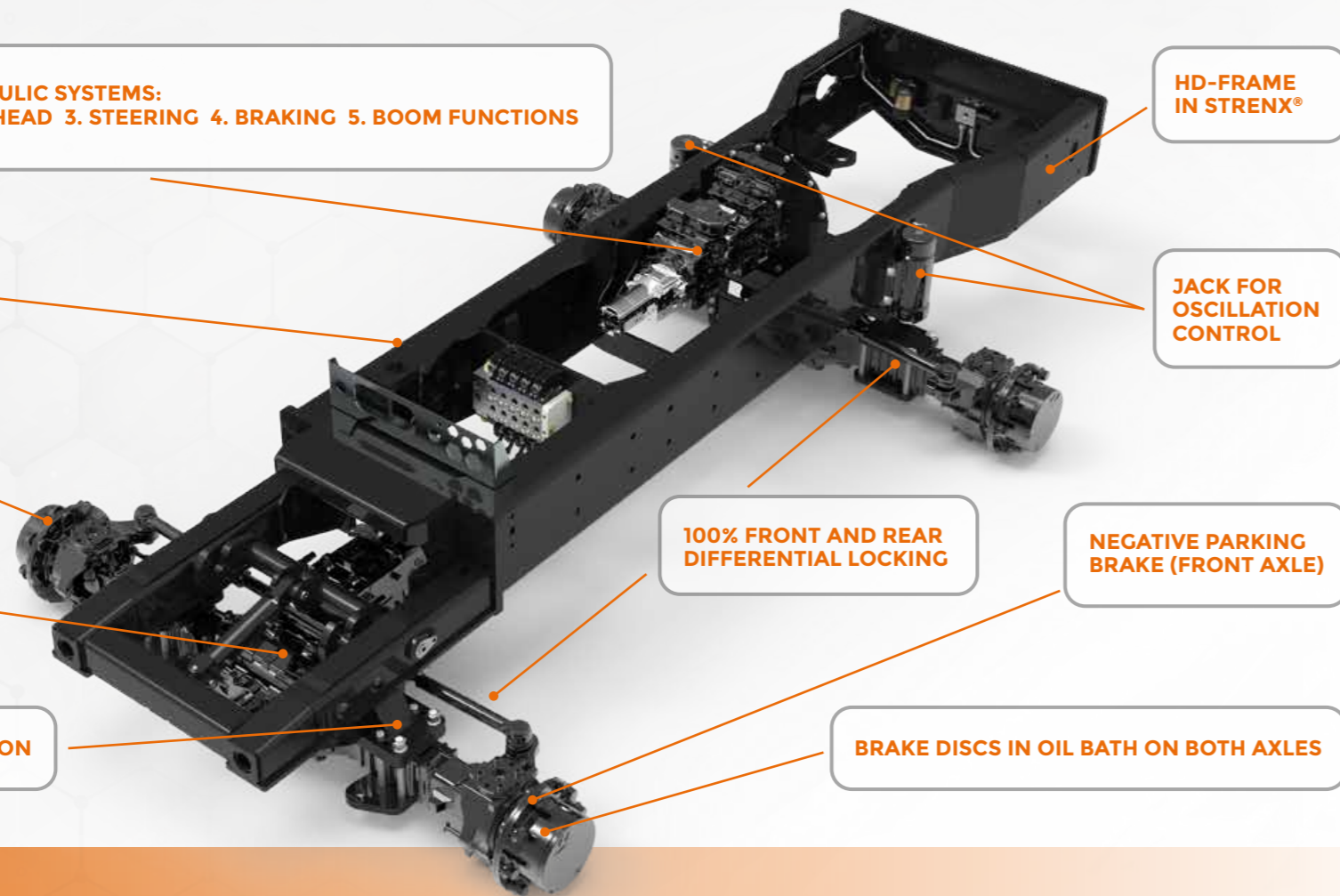

HD-FRAME IN STREX®

JACK FOR OSCILLATION CONTROL

100% FRONT AND REAR DIFFERENTIAL LOCKING

NEGATIVE PARKING BRAKE (FRONT AXLE)

BRAKE DISCS IN OIL BATH ON BOTH AXLES



AUTO LUBE
Automatic greasing system
OPTIONAL

The **AUTO LUBE** system is built with an electric greasing pump, electronically controlled, that allows to work independently and to be programmed to ensure the best grease of pins and bushing of the boom and of hydraulic cylinders. Moreover, this system allows an important reduction of maintenance hours.

JOYSTICK
Simple and intuitive

High quality joystick with proportional main controls that allows a precise and smooth control of the attachments. It allows to move up to 3 boom functions at the same time with an excellent gradual movement.



VEGETATION MAINTENANCE



WINTER ROAD SERVICE



CONSTRUCTION SITES WORK



FORESTRY WORKS



MULTIFUNCTION

Multifunction Machine for 1000 applications

ILF **Kommunal** is a multifunction machine, essential for those who use different attachments for multiple jobs.

It can be configured very quickly with the quick coupling system of the attachment. The wide range of accessories available makes it incomparable from the economic point of view if compared to an agricultural tractor. It can be used for vegetation and winter roads maintenance, it can replace dedicated machines such as sweepers, forklifts or wheel loaders, etc.

ILF **Kommunal** is the best choice for a year-round use, a unique multifunction tool!



TECHNICAL DATA

TECHNICAL DATA AND DIMENSIONS

* With Mitas tires 445/65 R 22.5
 ** With Alliance tires 600/50 R 22.5
 Technical and construction specifications may be subject to change without prior notice.



Compressor air set with tank (1,8 gal) **OPTIONAL**



Tools compartment



Integrated steps



Backup camera **OPTIONAL**



CLEANFIX® reversible self-cleaning fan **OPTIONAL**



Cabin porthole **OPTIONAL**

CABIN

Cabin homologation	ROPS - FOPS (1 st level)
Steering wheel	Adjustable
Joystick	Electronic
Air conditioning	Electronic
Rear glasses	Darkened anti UV
Adjustable seat	Air suspension
Power socket	12 V
Battery switch	Automatic

ENGINE

Brand	Deutz TCD 3.6
Type	4 Cylinders Diesel
Power	143 HP
Injection	Common Rail
Exhaust emissions	EPA Tier 4f
Alternator	120 A.
Fuel tank capacity	42 gal
Reversible self cleaning fan	CLEANFIX (optional)
Pre-heating air engine intake	
Air intercooler radiator	
Reinforced cooler radiator	
Computer for visualization engine data	

TRANSMISSION AND BRAKES

Transmission	Hydrostatic
Traction	4x4 (permanent)
4 steering wheels radius	7,6 ft
Tires	Standard: 445/65 R. 22,5
Speed variation	0 - 24 mph (continuous)
Manual gearbox	2 gears
Wheel alignment	Electronic control
Front axle	Fixed
Rear axle	Oscillating
Steering axles	2 steering axles
Axle block	Front 100%
	Rear 100%
Parking brake	Negative
Service brakes	6 discs for axle

SIZE AND WEIGHT

A Height	116 in
B Width	89* - 97** in
C Length	176 in
D Wheelbase	69 in
Peso (Without attachment)	14.374 lb
Peso (With attachment)	23.148 lb

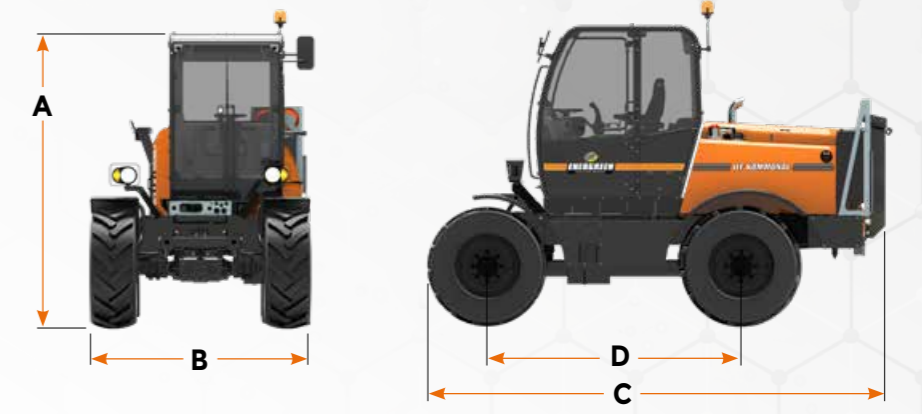

HYDRAULIC SYSTEM

Pumps and motors in closed circuits	
High flow pump	Piston
Trasmission pump	Piston
Pumps and motors in open circuits	
Boom movements	Gear
Brakes system	Gear
Steering system	Gear
Hydraulic distributor	Proportional
Hydraulic oil	Standard: ISOVG H46



TIRES

WIDE RANGE OF TIRES FOR EVERY TYPE OF USE; TIRES FOR BOTH OFF-ROAD AND ON THE ROAD

<p>STANDARD</p> <p>ROAD AND OFF-ROAD</p> <p>CONTINENTAL / MITAS MPT 445/65 R 22,5</p>	<p>OPTIONAL</p> <p>ROAD</p> <p>NOKIAN 460/65 R 24</p>	<p>OPTIONAL</p> <p>ROAD</p> <p>MICHELIN XF 18 445/70 R 19,5</p>	<p>OPTIONAL</p> <p>OFF-ROAD</p> <p>ALLIANCE 600/50 R 22,5 331 8 F offset - 25</p>
---	---	---	---

TIRES - ACCESSORIES - OPTIONAL



ILF KOMMUNAL

     **ENERGREENAMERICA.COM**



SELF-PROPELLED HYDROSTATIC MACHINES



Local dealership



ENERGREEN America · 227 Trade Ct. · Aiken · SC 29805 · USA
Phone 470 989 2600 · info@energgreenamerica.com
www.energgreenamerica.com

PROFESSIONAL MACHINES AND ATTACHMENT



ELUSD0700105-0124 - © Energgreen America 2024 - All rights reserved
Photo, technical and constructive characteristics subjected to modification without reporting requirement.