

**ILF ASPEN** 143HP



**ENERGREEN**<sup>®</sup> *America*

Professional Machines



SELF-PROPELLED  
HYDROSTATIC  
MACHINES



**ILF** SELF-PROPELLED

**SELF-PROPELLED  
HYDROSTATIC MACHINES**





# BRUSHCUTTER

## Professional Brushcutter

.....

**ILF Aspen** is a professional brushcutter to operate all year round in the management of vegetation and road maintenance. On the front side, it is equipped with a strong and reliable **boom which length can go from 19 ft to 30 ft.** This boom is designed not only for overcoming obstacles while working along roads, but also for reaching points on long distance, even in a vertical sense. It also offers great comfort of work, thanks to an excellent visibility of the working environment through a large window.

**ILF Aspen** is a machine extremely reliable and safe in any operating context and it turns out to be the best solution for administrations and public companies.

## ILF ASPEN





# STRENGTHS

## ILF ASPEN



## STRENGTHS



### Safety and Comfort

- FOPS-ROPS certified cabin
- High visibility panoramic windshield
- Excellent working ergonomics
- SCD Stability Control Device



### Quality

- Chassis made of special reinforced steel
- Certified components
- Deutz 143 HP EPA Tier 4f powerful engine
- Heavy Duty hydrostatic transmissions



### Multifunction

- Sturdy boom
- Several tools available
- Green maintenance
- Aerial pruning and forestry work



### Productivity

- Multifunction boom
- Excellent maneuverability on all surfaces
- Easy and smart to use
- 360° visibility







# BRUSHCUTTER

## Naturally Green

**ILF ASPEN**

.....

**Energreen** is a specialist in machinery and accessories for vegetation management and its remarkable experience has been transferred into this tool-carrier. **ILF Aspen** is unbeatable when working in vegetation maintenance along roads and in other activities connected to public roadways, through specific and reliable equipment.

**ILF Aspen** is the perfect solution, affordable and reliable for all needs and requests of road maintenance.





# 360° VISIBILITY



**GREAT VISIBILITY OF THE WHEEL**



## Complete Visibility of the Working Environment

When getting inside the ILF **Aspen** the first surprising feature is the large windshield that offers a maximum 360° visibility for the full control of the working environment.

The adjustable steering wheel, comfortable seat and intuitive and ergonomic operation established immediately, a strong feeling between the operator and the machine, that, thanks to its equipment makes even the most tough working day much easier.







# MANOEUVRABILITY



## Agility and Accuracy in the Movements

The polyvalent soul of this tool-carrier is highlighted also from the 4-wheel drive traction system, all steering, hydraulically configurable from the cab control in 3 different operating modes:

- **2 front steering wheels**, for the maximum agility on road movement.
- **4 steering wheels**, a system that halves the turning range of the machine, ideal for working in narrow areas.
- **4 parallel steering wheels (crab)**, useful for moving special tools or for moving away from an obstacle.

**2 STEERING WHEELS**

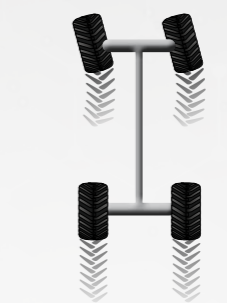

**4 STEERING WHEELS CONCENTRIC**



**4 STEERING WHEELS PARALLEL**

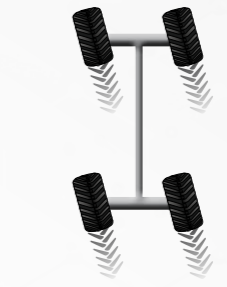





# TELESCOPIC BOOM



This boom has been designed to work with an extension up to 28 ft wide and 33 ft in height. Its particular geometry enhances the features for road maintenance where it is required a combination of mowing along the roadside and tree trimming. The sturdy telescopic extension allows a great work flexibility and maximum performance even in difficult situations.

MOD.	A	B	C	D	E	F
FAST 6	11,5'	19,6'	24'	10'	5,2'	10,5'
FAST 7	15,6'	23'	27,6'	10,3'	5,4'	10,6'
FAST 9	22,4'	29'	33'	10,3'	5,45'	10,7'

All dimensions are to be considered with a 120 cm NEW SPEED flail head in the most extreme fixing position.

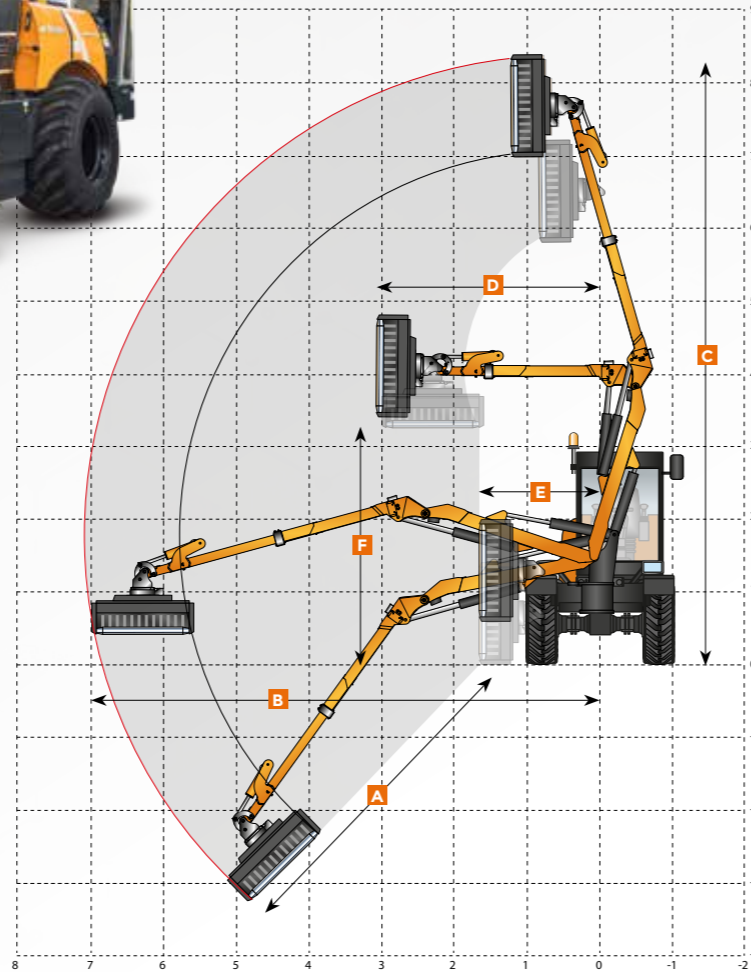

Technical and construction specifications may be subject to change without prior notice.

## ATTACHMENTS

THE SUITABLE TOOL FOR EVERY JOB



FORESTRY HEAD



SAW BAR



POWER SHEARS



CUTTER BAR



EXTRA TRUNK



STUMP GRINDER



FORC-ONE



ORANGE PEEL GRAPPLE



TRUNK PINCERS



DITCH CLEANER



IRON BRUSH



ROTATOR UNIT

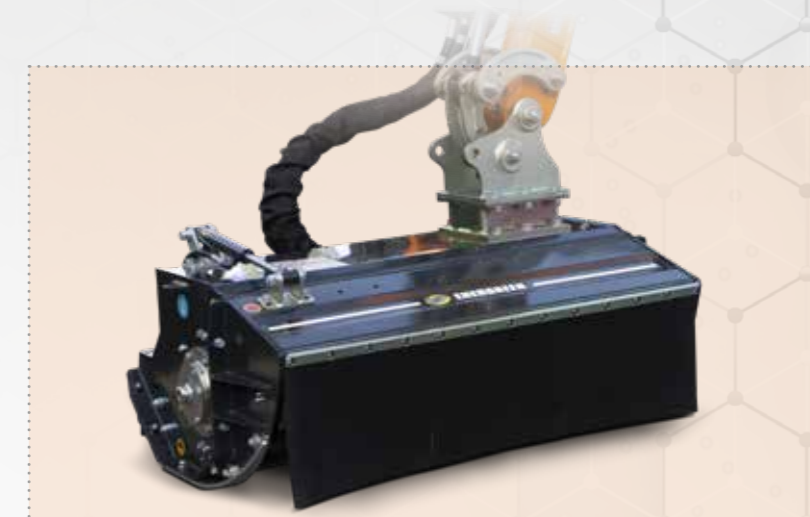

## NEW SPEED 47" and 59" FLAIL HEAD

Special steel frame - Standard frontal hydraulic opening  
Adjustable roller - Five types of rotor shaft  
Engine 35 cc - Cutting diameter 3 1/2" max.  
(Hydraulic opening is removable)



ROTATOR UNIT FOR 180° ATTACHMENTS ROTATION

# ATTACHMENTS



# TECHNICAL DATA

TECHNICAL DATA AND DIMENSIONS



## SIMPLE AND INTUITIVE JOYSTICK

Simple and intuitive joystick equipped with a proportional distributor. It allows you to control up to 3 boom functions at the same time with an excellent gradual movement, and it also allows the lock of the boom suspended in any position.



Large storage area for tools



Integrated steps



Cabin porthole **OPTIONAL**



Mudguards set **OPTIONAL**



Cleanfix® Reversible self cleaning **OPTIONAL**

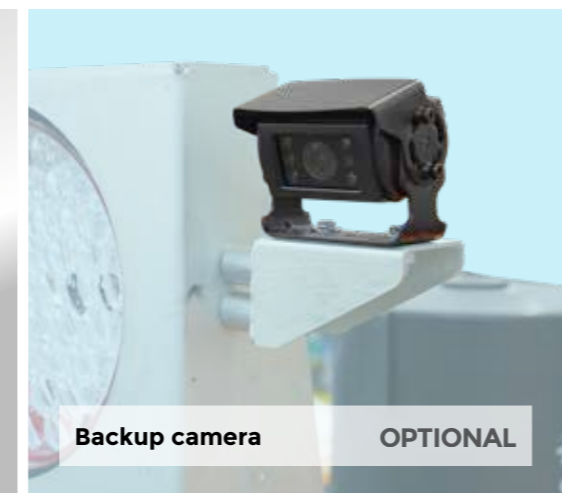

Backup camera **OPTIONAL**

## CABIN

Cabin homologation	ROPS - FOPS (1 <sup>st</sup> Level)
Steering wheel	Adjustable
Joystick	Electronic
Air conditioning	Electronic
Rear glasses	Darkened anti UV
Adjustable seat	Air suspension
Power socket	12 V
Battery switch	Automatic

## ENGINE

Brand	Deutz TCD 3.6
Type	4 Cylinders Diesel
Power	143 HP
Injection	Common Rail - 4 valves for cylinders
Exhaust emissions	EPA Tier 4f
Alternator	120 A.
Fuel tank capacity	42 gal
Fan	CLEANFIX (optional)
Pre-heating air engine intake	
Air intercooler radiator	
Reinforced cooler radiator	
Computer for visualization engine data	

## TRANSMISSION AND BRAKES

Transmission	Hydrostatic
Traction	4x4 (permanent)
Steering radius	7.6 ft
Tires	Standard: 500/45 R 22,5
Speed variation	0 - 24 mph (continuous)
Manual gearbox	2 gears
Wheel alignment	Electronic control
Front axle	Fixed
Rear axle	Oscillating
Steering axles	2 steering axles
Axle block	Front 100% Rear 100%
Parking brake	Negative
Service brakes	6 discs

## SIZE AND WEIGHT

A Height	110 in
B Width	94 in
C Length	222 in
D Wheelbase	96 in
Weight	20000* lbs

Dimensions with standard tyres

\* Weight with Fast 7 arm and New Speed flail head.



## TIRES

WIDE RANGE OF TIRES FOR EVERY TYPE OF USE; TIRES FOR BOTH OFF-ROAD AND ON THE ROAD



STANDARD  
ROAD  
BKT 500/45 R 22,5



OPTIONAL  
ROAD  
NOKIAN 460/65 R 24



OPTIONAL  
ROAD AND OFF-ROAD  
CONTINENTAL / MITAS MPT 445/65 R 22,5



OPTIONAL  
OFF-ROAD  
ALLIANCE 600/50 R 22,5 331 8 F offset - 25

## HYDRAULIC SYSTEM

Pumps and motors in open circuits	
Boom movement	Gear
Brakes system	Gear
Steering system	Gear
Pumps and motors in closed circuits	
Flail head pump	Piston
Translation pump	Piston
Hydraulic distributor	sections
Hydraulic oil	ISOVG H46
Oil pressure	210 - 290 bar

# TIRES, ACCESSORIES AND OPTIONAL

Technical and construction specifications may be subject to change without prior notice.





**ILF ASPEN**

     **ENERGREENAMERICA.COM**



# SELF-PROPELLED HYDROSTATIC MACHINES



Local dealership



ENERGREEN America · 227 Trade Ct. · Aiken · SC 29805 · USA  
Phone 470 989 2600 · info@energgreenamerica.com  
www.energgreenamerica.com

PROFESSIONAL MACHINES AND ATTACHMENTS



ELUSD1700105-0124 - © Energgreen America 2024 - All rights reserved  
Photo, technical and constructive characteristics subjected to modification without reporting requirement.