

Microwave Level Transmitter for General Application

8188 / 8189

- Universal level measurement device for fluids
- Liquid interface measurement
- Insensitive to dust and steam
- 4-20 mA/HART - 2 wires, ATEX/IECEX approvals Ex



Level measurement devices designed for continuous level measurement. The units are suitable to liquids, for industrial use in all areas of process technology.

Technical Data

Housing / Cover	PBT, Stainless steel 316L / PC
Seal ring / Ground terminal	NBR / Stainless steel 316L
Display	LCD in full dot matrix
Ambient temperature	-4 to 176 °F
Current limitation	21.5 mA (max. output current)
Electrical connections	Cable gland M20 x 1.5
Output signal	4-20 mA/HART
Output Load Max.	See datasheet
Deviation	± 2 mm (See drawing in datasheet)
Min. Dielectric	Rod and cable $\epsilon_r > 1.6$ Coax. $\text{-}\phi 21.3 \text{ mm } \epsilon_r > 1.4$
Process temperature	-40 to 302 °F
Temperature drift	0.03% /10K
Measurement type	Level of liquids
Protection	IP66/IP67 with M20 x 1.5 gland mounted and tightened

Options

- ATEX/IECEX versions
- Other hygienic fittings

Envelope Dimensions [inch] (see datasheet for details)

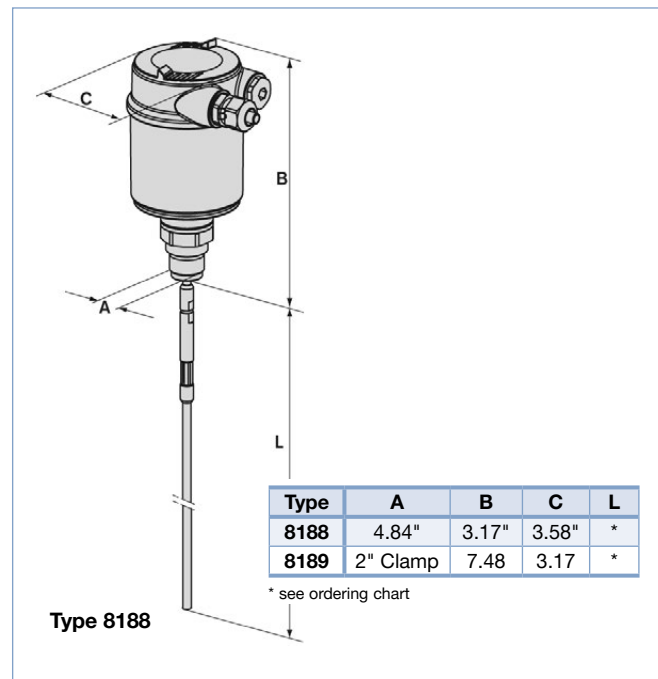

Ordering Chart

Specification	Operating voltage	Output	Probe	Length	Electrical connection	Item no.
Type 8188						
NPT 3/4" mounting thread, PN6, temp. max 80 °C	9.6-35 V DC	4-20 mA/HART (2 wires)	Rod	1 m	Cable gland M20 x 1.5	565801
				2 m	Cable gland M20 x 1.5	565805
			Cable	5 m	Cable gland M20 x 1.5	565813
				10 m	Cable gland M20 x 1.5	565817
			Coax	1 m	Cable gland M20 x 1.5	565827
				2 m	Cable gland M20 x 1.5	565828
NPT 1" mounting thread, PN40, temp. max 150 °C	9.6-35 V DC	4-20 mA/HART (2 wires)	Rod	1 m	Cable gland M20 x 1.5	565803
				2 m	Cable gland M20 x 1.5	565807
			Cable	5 m	Cable gland M20 x 1.5	565815
				10 m	Cable gland M20 x 1.5	565819
			Coax	1 m	Cable gland M20 x 1.5	565829
				2 m	Cable gland M20 x 1.5	565830
Type 8189						
Specifications	Voltage supply	Output	Probe	Length	Electrical connection	Item no.
Clamp 2"	9.6-35 V DC	4-20 mA/HART (2 wires)	Rod	1 m	Cable gland M20 x 1.5	565850
				2 m	Cable gland M20 x 1.5	565852

Note: Display/programmer (559279) included