



ELECTRONIC PRESSURE MEASUREMENT PRODUCTS

Model DDMC Digital Meter/Controller

DESCRIPTION

The AMETEK Model DDMC Digital Meter/Controller powered by 85 to 265 VAC will display data from transmitters, transducers, scales, and other process instruments. It provides 24 volt excitation, alarm relays, and optional analog output for process control functions.

FEATURES

- 0-20 mA, 4-20 mA, 0-5 V, 1-5 V, and ± 10 V inputs
- NEMA 4X, IP65 front
- Universal 85-265 VAC or 12/24 VDC input power
- Large dual-line 6-digit display, 0.60" and 0.46"
- Dual-scale for level applications – single input
- Isolated 24 VDC @ 200 mA transmitter power supply
- Math functions for flow and round horizontal tanks
- Programmable displays and function keys
- 32-point, square root, or exponential linearization
- Multi-pump alternation control
- 2 or 4 relays and isolated 4-20 mA output options
- External 4-relay expansion module option allows for up to 8 relays maximum
- USB serial communication option
- MODBUS[®] RTU communication protocol standard (requires serial communication adapter)
- Configure, monitor and datalog from a PC with free DDMC Meter View software
- Onboard digital input

SPECIFICATIONS

Display:

Main display: 0.60" (15 mm) high, red LEDs
 Second display: 0.46" (12 mm) high, red LEDs
 6 digits each (-99999 to 999999), with lead zero blanking

Display Intensity: Eight user selectable intensity levels

Display Update Rate: 5/second (200 ms)

Overrange: Display flashes 999999

Underrange: Display flashes -999999

Programming Methods: Four front panel buttons, digital inputs, PC and multi-point linearization utility, or cloning using Copy function.

Noise Filter: Programmable from 2 to 199 (0 will disable filter)

Filter Bypass: Programmable from 0.1 to 99.9% of calibrated span

Recalibration: All ranges are calibrated at the factory. Recalibration is recommended at least every 12 months.

Max/Min Display: Max/Min readings reached by the process are stored until reset by the user or until power to the meter is turned off.

(specifications continued on next page)



**Model DDMC Digital Meter/Controller
 in NEMA 4 Enclosure**

with readout close-up above





ELECTRONIC PRESSURE MEASUREMENT PRODUCTS

Model DDMC Digital Meter/Controller

SPECIFICATIONS (continued)

Password: Three programmable passwords restrict modification of programmed settings.

Pass 1: Allows use of the F1–F3 function keys

Pass 2: Allows use of the F1–F3 function keys and changing the set/reset points

Pass 3: Restricts all programming and F1–F3 keys

Note: Digital inputs are not password protected, except programming functions.

Non-Volatile Memory: All programmed settings are stored in non-volatile memory for a minimum of ten years if power is lost

Power Options: Standard universal 85-265 VAC 50/60 Hz, 90-265 VDC, 20 W max or jumper selectable 12/24 VDC ± 10%, 15 W max

Optional 12/24 VDC input power model

Fuse: Required external fuse: UL Recognized, 5 A max, slow blow; up to 6 meters may share one 5 A fuse

Isolated Transmitter Power Supply: Terminals P+ & P-: 24 VDC ± 5% @ 200 mA max (standard), (12/24 VDC powered models rated @ 100 mA max). 5 or 10 VDC @ 50 mA max, selectable with internal jumper J4.

Normal Mode Rejection: Greater than 60 dB at 50/60 Hz

Isolation: 4kV input / output-to-power line 500 V input to output or output-to-P+ supply

Overvoltage Category:

Installation Overvoltage Category II: Local level with smaller transient overvoltages than Installation Overvoltage Category III.

Environmental:

Operating temperature range: -40 to 65°C

Storage temperature range: -40 to 85°C

Relative humidity: 0 to 90% non-condensing

Connections: Removable screw terminal blocks accept 12 to 22 AWG wire, RJ45 for external relays and serial communication adapters.

Enclosure: 1/8 DIN, high impact plastic, UL 94V-0, color: black

Mounting: 1/8 DIN panel cutout required: 3.622" x 1.772" (92 mm x 45 mm). Two panel mounting bracket assemblies are provided.

Tightening Torque: Screw terminal connectors: 5 lb-in (0.56 Nm)

Overall Dimensions: 4.68" x 2.45" x 5.64" (119 mm x 62 mm x 143 mm) (W x H x D)

Weight: 9.5 oz (269 g)

Warranty: 2 years parts and labor

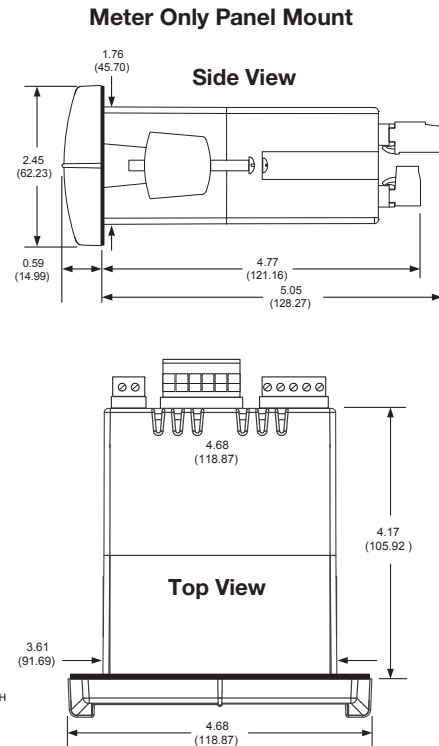
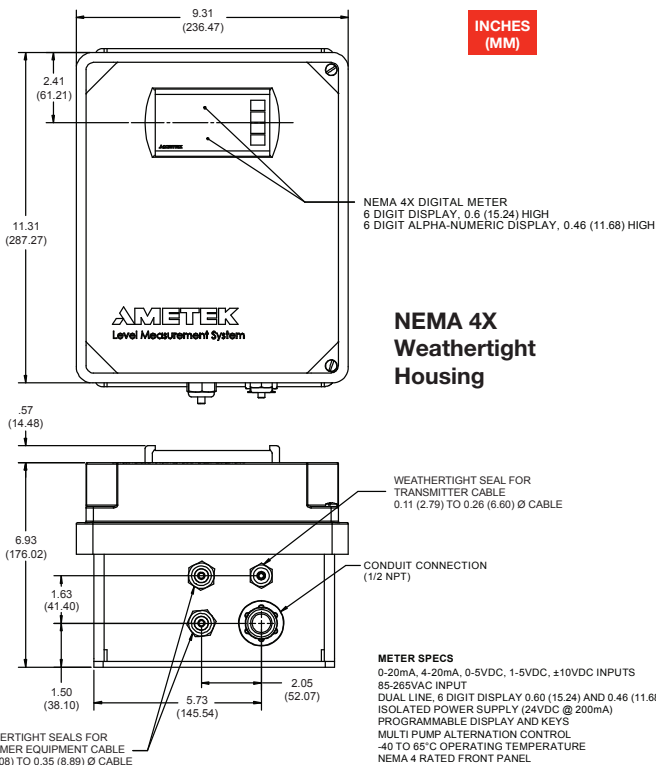



ELECTRONIC PRESSURE MEASUREMENT PRODUCTS

Model DDMC Digital Meter/Controller

Model Numbering:	
● DDMC digital meter/controller	
DDMC	Digital meter/controller
DDMCD	12/24 DC input only
● Meter output	
A	2 relays
B	2 relays, analog output 4-20mA
C	4 relays
D	Display ONLY, no relays
● Housing	
0	Panel mount
1	NEMA 4X weathertight housing
● DC surge protection**	
0	No DC surge protection
1	Surge protection for signal line between meter and transmitter (LM912)
2	Surge protection for signal line between meter and customer equipment (LM912)
3	Surge protection for signal line between meter and transmitter and meter and customer equipment (LM912 X2)
● AC surge protection**	
0	No AC surge protection
1	115 VAC surge protection for input line to the meter (LM918)
2	230 VAC surge protection for input line to the meter (LM919)
DDMC	B
1	0
0	0

* Consult factory for additional options.

** Surge protectors wired into the box if ordered with NEMA 4X enclosure

Math Functions

Non-linear input signals (i.e. weirs and flumes, differential pressure, etc.) can be linearized with the DDMC's simple to use built-in math functions, such as: square-root extractor, exponential linearizer, horizontal round tank linearizer, or the DDMC's powerful general purpose 32-point linearizer.

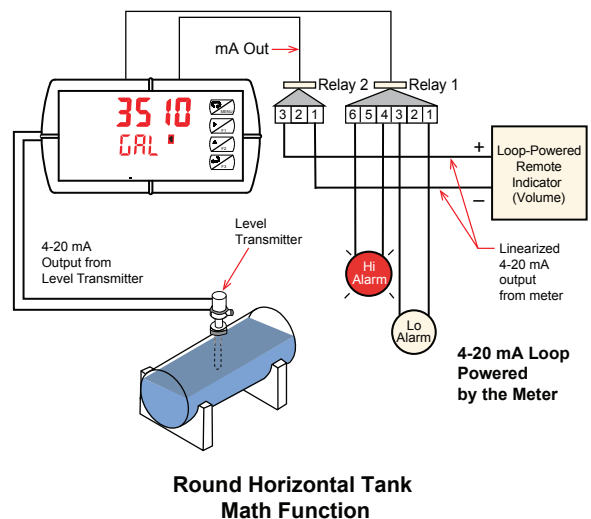
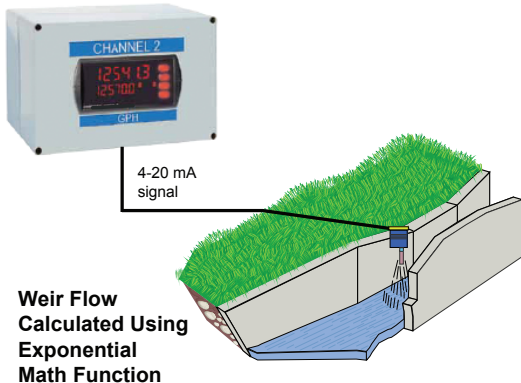



ELECTRONIC PRESSURE MEASUREMENT PRODUCTS

Model DDMC Digital Meter/Controller

Meter Copy

The Copy function is a standard feature used to copy (or clone) all the settings from one meter to other meters requiring exactly the same setup and programming (i.e. type of input, scaling, decimal point, filter, bypass, etc.).

Requires only an optional cable assembly 3' (0.9m) – Order part #K516132.



Relay Outputs

The DDMC has up to four 3 A Form C relays (SPDT) with multiple power loss fail-safe options. Relays can be configured for proper protective action upon input loop break. Relay ON and OFF delay times are user adjustable. Up to eight front panel indicators show alarm and/or relay state. All relays can be configured for 0-100% deadband.

Relay Operation/Configuration

There are powerful relay functions that can be configured in the DDMC meter, including:

- Automatic reset only (non-latching)
- Automatic and manual reset at any time (non-latching)
- Latching (manual reset only)
- Latching with clear (manual reset only after alarm condition has cleared)
- Pump alternation control (automatic reset only)
- Sampling (activated for a user-specified time)
- User selectable fail-safe operation
- Relay action for loss (break) of 4-20 mA input signal
- Time delay (on and off), independent for each relay
- Manual control mode
- Interlock relay mode

Analog Output

The isolated analog retransmission signal can be configured to represent the process variable (PV), maximum (peak) value, minimum (valley) value, the value for any of the eight relay set points, or Modbus input. While the output is nominally 4-20 mA, the signal will accurately accommodate under- and over-ranges from 1 to 23 mA.

Manual Output Control

Take control of any output with this feature. All relays can be forced ON or OFF, and the 4-20 mA output signal can be set to any value within its range. When the relays and 4-20 mA output are controlled manually, an LED labeled "M" is turned on and the associated alarm LEDs (1-8) flash every 10 seconds indicating that the meter is in manual control mode.

Isolated Transmitter Power Supplies

A powerful 24 V @ 200 mA power supply is a standard feature on the DDMC meter. It can be configured for 5, 10, or 24 V (default) by means of a simple internal jumper (see manual). An additional power supply (24 V @ 40 mA) is standard with the 4-20 mA output option.

4-Relay Expansion Module

Relays: Four Form A (SPST) rated 3 A @ 30 VDC and 125/250 VAC resistive load; 1/14 HP (\approx 50 watts) @ 125/250 VAC for inductive loads. Order kit #K740366

Isolated 4-20 mA Transmitter Output

Output Source: Process variable (PV), max, min, set points 1-8, manual control setting, or Modbus input

Scaling Range: 1.000 to 23.000 mA for any display range

Calibration: Factory calibrated: 4.000 to 20.000 = 4-20 mA output

Analog Output Programming: 23.000 mA maximum for all parameters: Overrange, underrange, max, min, and break

Accuracy: $\pm 0.1\%$ of span ± 0.004 mA

Temperature Drift: 0.4 $\mu\text{A}/^\circ\text{C}$ max from 0 to 65 $^\circ\text{C}$ ambient, 0.8 $\mu\text{A}/^\circ\text{C}$ max from -40 to 0 $^\circ\text{C}$ ambient

Note: Analog output drift is separate from input drift.

Isolated Transmitter Power Supply: Terminals I+ & R: 24 VDC $\pm 5\%$ @ 40 mA maximum, may be used to power the 4-20 mA output or other devices.

External Loop Power Supply: 35 VDC maximum

Output Loop Resistance:

Power supply	Minimum	Maximum
24 VDC	10 Ω	700 Ω
35 VDC (external)	100 Ω	200 Ω



ELECTRONIC PRESSURE MEASUREMENT PRODUCTS

Model DDMC Digital Meter/Controller

Serial Communications

USB Serial Adaptor Kit – Allows for direct connection of a DDMC meter to the USB port of a PC. Required for free Meter View software download and PC programming. Order kit #K516131.



Part #K516131

Process Input

Inputs: Field selectable: 0-20, 4-20 mA, ± 10 VDC (0-5, 1-5, 0-10 V), Modbus PV (Slave)

Accuracy: $\pm 0.03\%$ of calibrated span ± 1 count, square root and programmable exponent accuracy range: 10-100% of calibrated span

Temperature Drift: 0.005% of calibrated span/ $^{\circ}$ C max from 0 to 65 $^{\circ}$ C ambient, 0.01% of calibrated span/ $^{\circ}$ C max from -40 to 0 $^{\circ}$ C ambient

Math Function: Linear, square root, programmable exponent, or round horizontal tank volume calculation

Multi-Point Linearization: 2 to 32 points for PV or PV1. 2 to 8 points for PV2 (dual-scale level feature)

Programmable Exponent: 1.0001 to 2.9999

Low-Flow Cutoff: 0-999999 (0 disables cutoff function)

Decimal Point: Up to five decimal places or none: d.ddddd, dd.dddd, ddd.ddd, dddd.dd, dddd.d, or dddddd

Calibration Range: 4-20 mA: minimum span input 1 and input 2: 0.15 mA. ± 10 V: minimum span input 1 and 2: 0.10 V. An error message will appear if input 1 and input 2 signals are too close together.

Input Impedance:

Voltage ranges: greater than 1 M Ω

Current ranges: 50 - 100 Ω (depending on resettable fuse impedance)

Input Overload: Current input protected by resettable fuse, 30 VDC max. Fuse resets automatically after fault is removed.

Features and Functions

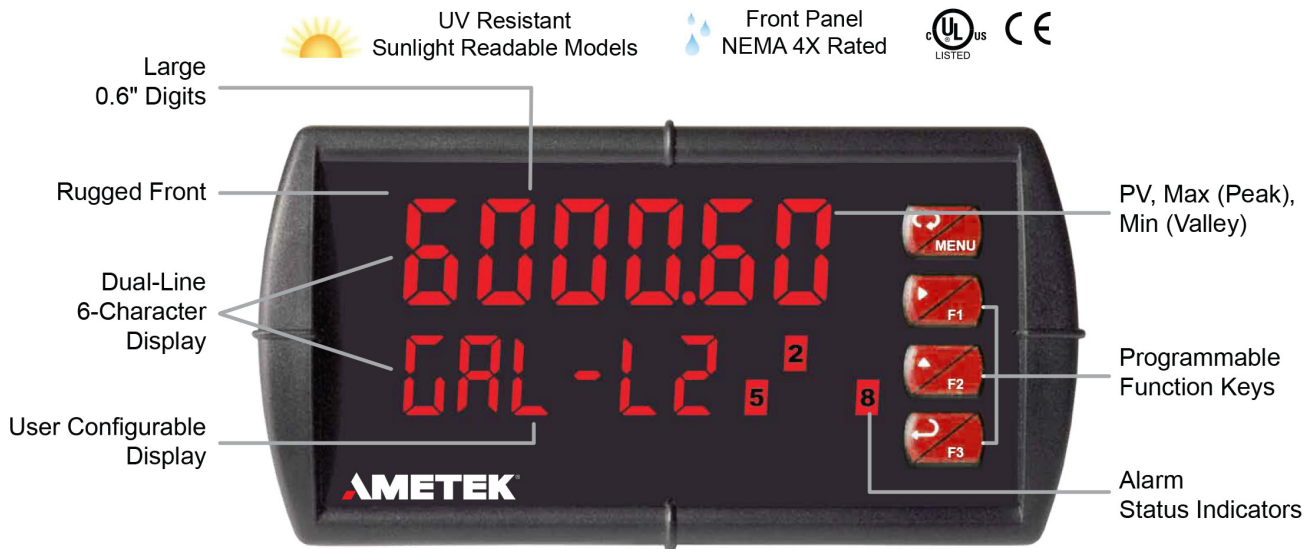



ELECTRONIC PRESSURE MEASUREMENT PRODUCTS

Model DDMC Digital Meter/Controller

Feature Rich and Flexible

The DDMC meter boasts specifications and functionality that clearly make it one of the most advanced process meters available. Its dual-line 6-digit display (999,999), advanced math functions, function keys, Modbus RTU serial communications, and optional expansion modules are only a few of the features found on the DDMC PD6000.

Front Panel Display

Precise, Accurate, and More Informative

DDMC large 0.6" upper display provides a highly accurate and precise 6-digit view of the process measurement. Its 24-bit A/D is accurate to $\pm 0.03\%$ of calibrated span ± 1 count.



Configurable

The upper display can be programmed to indicate PV, maximum (peak), minimum (valley), alternating maximum/minimum, one of eight alarm set points, or Modbus input. The lower display can also be configured to display engineering units, set points, user defined legends, or simply turned off.

Function Keys

There are three function keys available to the user. These keys can be programmed to trigger certain events (i.e. acknowledge alarms, reset max and/or min, disable/enable output relays, or hold current relay states), provide direct menu access points, and more.

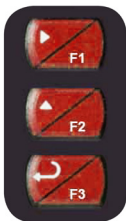

Rugged

A unique front panel design makes the DDMC nearly impenetrable in typical applications. Here, the DDMC easily survives a direct hit on the display from a heavy 2" solid stainless steel ball dropped from eight feet.



Easy to Use

The user friendly dual-line display makes the DDMC easy to set up and program. No jumpers to set for input selection. All setup and programming are done via the front panel. Three levels of password protection help maintain the reliability of the programming.



Field Expansion modules

Add functionality to the DDMC in the field with easy-to-install external expansion modules. The menu items for these modules do not appear until the module is connected, simplifying the basic menu.

Relay Expansion Module

An external module containing four 3 A Form A (SPST) relays can be added to the DDMC at anytime. Removable screw terminal blocks accept 12 to 22 AWG wire.



Communication Module

Serial communications on the DDMC can be added anytime with external USB communication adapter kit.



ELECTRONIC PRESSURE MEASUREMENT PRODUCTS

Model DDMC Digital Meter/Controller

Multi-pump Alternation

Up to 8 pumps can be alternated and sequenced with the DDMC digital meter/controller.

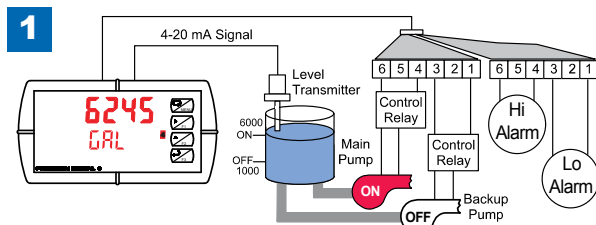

Relay #4 turns the main pump on at 6000 gallons and turns it off at 1000 gallons.

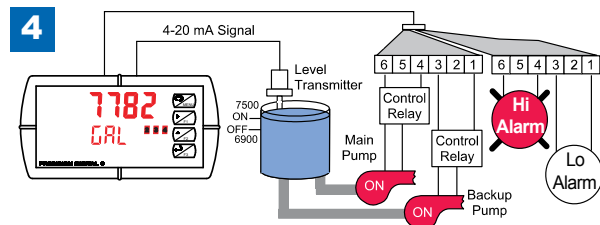

Relay #2 trips the High Level Alarm at 7500 gallons and resets at 6900 gallons.

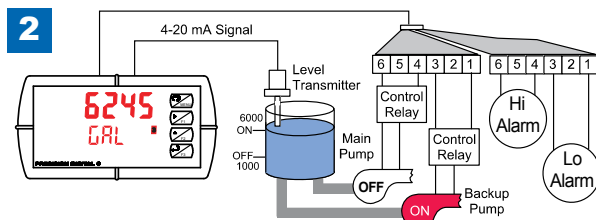

With the Pump Alternation feature activated, the next time the level reaches 6000 gallons, relay #3 transfers and starts the backup pump.

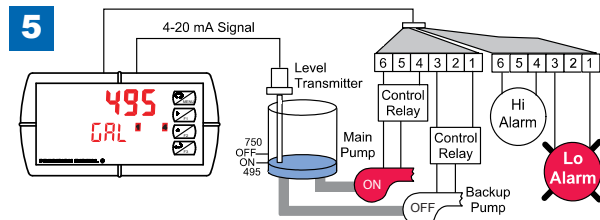

Relay #1 trips the Low Level Alarm at 495 gallons and resets at 750 gallons.

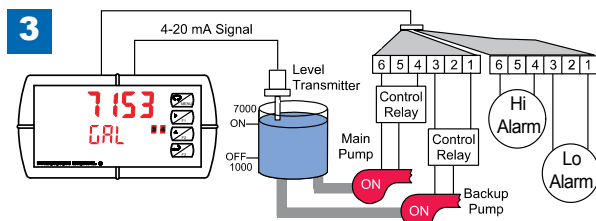

If the backup pump is not able to keep up, and the level reaches 7000 gallons, relay #4 transfers and starts the main pump as well.

ELECTRONIC PRESSURE MEASUREMENT PRODUCTS

Model DDMC Digital Meter/Controller

Connections

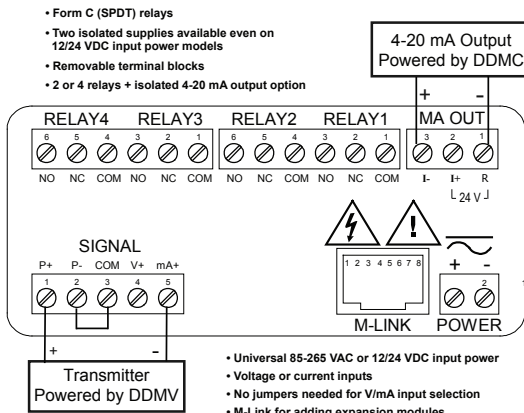

Relays

Rating: 2 or 4 SPDT (Form C) internal and/or 4 SPST (Form A) external; rated 3 A @ 30 VDC and 125/250 VAC resistive load; 1/14 HP (\approx 50 watts) @ 125/250 VAC for inductive loads such as contactors, solenoids, etc.

Noise Suppression: Noise suppression is recommended for each relay contact switching inductive loads

Deadband: 0-100% of span, user programmable

High or Low Alarm: User may program any alarm for high or low trip point. Unused alarm LEDs and relays may be disabled (turned off).

Relay Operation: Automatic (non-latching), latching (requires manual acknowledge), sampling (based on time), pump alternation control (2 to 8 relays), Off (disable unused relays and enable interlock feature, manual on/off control mode).

Relay Reset: User selectable via front panel buttons or digital inputs

- Automatic reset only (non-latching), when input passes the reset point
- Automatic and manual reset at any time (non-latching)
- Manual reset only, at any time (latching)
- Manual reset only after alarm condition has cleared (latching)

Note: Front panel button or digital input may be assigned to acknowledge relays programmed for manual reset.

Time Delay: 0 to 999.9 seconds, on and off relay time delays. Programmable and independent for each relay.

Fail-Safe Operation: Programmable and independent for each relay.

Note: Relay coil is energized in non-alarm condition. In case of power failure, relay will go to alarm state.

Auto Initialization: When power is applied to the meter, relays will reflect the state of the input to the meter.

Outputs

Relay Outputs

The DDMC has up to four 3 A Form C relays (SPDT) with multiple power loss fail-safe options. Relays can be configured for proper protective action upon input loop break. Relay ON and OFF delay times are user adjustable. Up to eight front panel indicators show alarm and/or relay state. All relays can be configured for 0-100% deadband.

Relay Operation/Configuration

There are powerful relay functions that can be configured in the DDMC meter, including:

- Automatic reset only (non-latching)
- Automatic and manual reset at any time (non-latching)
- Latching (manual reset only)
- Latching with clear (manual reset only after alarm condition has cleared)
- Pump alternation control (automatic reset only)
- Sampling (activated for a user-specified time)
- User selectable fail-safe operation
- Relay action for loss (break) of 4-20 mA input signal
- Time delay (on and off), independent for each relay
- Manual control mode
- Interlock relay mode

Analog Output

The isolated analog retransmission signal can be configured to represent the process variable (PV), maximum (peak) value, minimum (valley) value, the value for any of the eight relay set points, or Modbus input. While the output is nominally 4-20 mA, the signal will accurately accommodate under- and over-ranges from 1 to 23 mA.

Manual Output Control

Take control of any output with this feature. All relays can be forced ON or OFF, and the 4-20 mA output signal can be set to any value within its range. When the relays and 4-20 mA output are controlled manually, an LED labeled "M" is turned on and the associated Alarm LEDs (1-8) flash every 10 seconds indicating that the meter is in manual control mode.

Isolated Transmitter Power Supplies

A powerful 24 V @ 200 mA power supply is a standard feature on the DDMC meter. It can be configured for 5, 10, or 24 V (default) by means of a simple internal jumper (see manual). An additional power supply (24 V @ 40 mA) is standard with the 4-20 mA output option.



OPTIONS AND ACCESSORIES

Display Meters, Surge Protectors, Junction Boxes and Desiccants

DISPLAY METERS AND SYSTEMS

Model DDMC Digital Meter/Controller

Dual display meter provides power to the sensor with alarm and 4-20 mA analog output options. Standard panel mount housing or a NEMA 4X weathertight housing for field mounting is available. The weathertight housing also provides internal mounting locations for lightning and surge protectors.



LEVEL MATE™ III Level Measurement System

The complete LEVEL MATE III system includes a level sensor (various models are available), cable and a meter/controller all packaged in a NEMA 4X enclosure. Everything is factory programmed for easy installation and the LEVEL MATE III has an extended 2-year warranty.



Inside view of the NEMA 4X enclosure showing the desiccant and optional surge protectors. Unit is factory wired so that the user needs to connect power and sensor only.

JUNCTION BOXES

Model SBJ100 with Reusable Desiccant

These boxes are used on long cable runs and provide quicker access to atmospheric reference. SBJ100 provides a clean, dry enclosure with an internal, reusable desiccant canister.

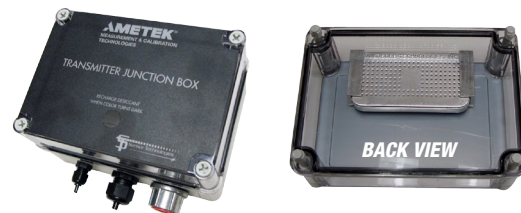

Back view of SBJ100 junction box that shows the reusable desiccant canister.

DESICCANTS

An initial desiccant is supplied with the SBJ100 and the LEVEL MATE III enclosure. The desiccant canister is reusable with visible color change when the time comes to replace the desiccant.

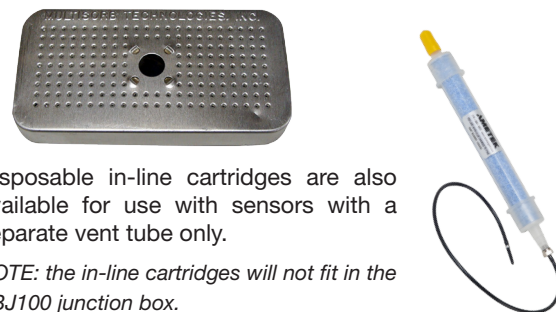

Disposable in-line cartridges are also available for use with sensors with a separate vent tube only.

NOTE: the in-line cartridges will not fit in the SBJ100 junction box.

LIGHTNING AND SECONDARY SURGE PROTECTORS

Lightning protection units are available to help protect systems and components from lightning and secondary surges. These LP units are available in both 30 VDC (LMA912) for 24 VDC supply on excitation/signal lines and analog meter output lines to protect the meter and/or the transmitter as well as 115 VAC (LMA918) and 230 VAC (LMA919) to protect the meter on AC power input lines.

