

**ILF ATHENA** 220HP



**ENERGREEN**<sup>®</sup> *America*

Professional Machines



SELF-PROPELLED  
HYDROSTATIC  
MACHINES



**SELF-PROPELLED**  
HYDROSTATIC MACHINES





49 ft  
BOOM

90° ROTATING  
CABIN

# BRUSHCUTTER

## Brushcutter Machine ideal for Road and Highway

# ILF ATHENA



ILF Athena is a professional brushcutter machine which, thanks to its innovative technological contents, offers uncomparable performance, great flexibility and operational safety.

The machine is equipped with a 49 ft telescopic boom, where in addition to the classic mulching head, it is possible to apply several tools.

On the front side of the machine it is possible to set a PTO lifter or a DIN plate, in order to apply a front accessory that can be used simultaneously with the brush cutter boom.



# STRENGTHS

## ILF ATHENA



## STRENGTHS



### Safety and Comfort

- 90° rotating cabin certified FOPS-ROPS
- High visibility panoramic windshield
- Excellent working ergonomics
- Stability Control Device
- Telescoping ballast for the maximum extension



### Quality

- 7" LCD display
- Deutz 220 HP powerful engine
- EPA Tier 4f emission
- Main parts made with special steel
- Heavy Duty hydrostatic transmission



### Multifunction

- Several tools available
- Green maintenance
- Aerial pruning and forestry work
- Winter viability
- Front and rear attachment for tools



### Productivity

- 49 ft telescopic boom
- Bidirectional work
- Operation with multiple implements
- Easy and smart to use
- 360° cabin visibility







7"  
LCD  
DISPLAY

# 360° VISIBILITY

## Complete Visibility of the Working Environment

Visibility is an essential element for a correct and safe use of the machine while working and moving.  
Visibility has always been one of Energreen strengths!

ILF Athena has a comfortable and spacious cabin, equipped with a large windshield which allows the operator to have an efficient and total view of the work, keeping a high level of comfort and physical wellness.

In terms of safety, the cabin is certified by FOPS-ROPS tests: anti-tipping, against the risk of falling objects, soundproofed, provided with an efficient cooling system, and equipped with all that features necessary to assure the operator a safe and comfortable working environment.

The 90° rotation of the cab makes viewing of the vegetation in both directions much easier. The rotating cabin allows the operator to always keep the correct body posture, avoiding stress and backpain or stiff neck, as well as managing the work with great comfort and care.



ROTATING CABIN





# CABIN COMFORT



FOPS-ROPS  
CERTIFIED

## Maximum Safety and Comfort

ILF Athena cabin is certified according to the FOPS-ROPS regulation that guarantees the protection against overturning and objects falling.

The cabin is completely isolated and efficiently air-conditioned thanks to a sealing system.

This multifunction machine is suited for working in dusty and noisy environments for many hours per day, still keeping a high level of comfort.

The cabin is available in three versions:  
**STANDARD - COMFORT - PRESTIGE**



### CABIN STANDARD

- 90° rotating cabin
- FOPS-ROPS certified cabin
- 7" LCD display
- Tilting and height-adjustable steering column
- Electronic direction control lever
- Adjustable armrest with Joystick
- Front windshield washer wiper
- Air conditioning with anti-pollen filter
- Left mirror
- Height-adjustable LED beacon
- Cabin door partially openable
- Darked anti-UV rear window, partially openable
- Lateral documents holder
- Automatic LED courtesy lights
- Emergency glass break hammer
- External electrical socket for 12 V services
- Internal 12 V DC socket
- Two-way USB socket
- Clothes hangers
- GRAMMER MAXIMO XXL seat with air suspension and adjustable lumbar shock absorber



### CABIN COMFORT

#### IN ADDITION TO THE «STANDARD CABIN» INSTALLATION

- Cruise Control
- Instant reverse pedal
- DAB/Bluetooth stereo
- No. 4 LED working lights
- Retractable sunshade on front windshield



### CABIN PRESTIGE

#### IN ADDITION TO THE «COMFORT CABIN» INSTALLATION

- Display with 1 reversing camera
- Twin LED beacon
- Porthole with grille, curtain and windscreen wiper
- Windshield wiper on the right side.
- 4.5 lbs fire extinguisher
- GRAMMER MAXIMO EVOLUTION DYNAMIC seat with larger seat dimensions, air suspension system, longitudinal shock absorber, side suspension, lumbar shock absorber and active climate control system



ADJUSTABLE STEERING WHEEL



MONITOR SCREEN WITH CAMERA



TOP PORTHOLE WITH GRILLE





# F15 BOOM



ILF Athena is equipped with a solid telescopic boom designed to work with an extension range up to 49 ft, both in depth and in height. The special design underlines its qualities for working along the routes, even where there are security barriers up to 3 ft. The telescopic extension allows to easily reach even the furthest and narrowest areas for operating on the green maintenance always keeping the performance at the top.







# AERIAL MAINTENANCE



## Aerial Maintenance

ILF **Athena** is the perfect machine for every type of aerial pruning. The strong 49 ft telescopic boom, equipped with professional tools such as cutter discs bars, power shears and pruning scissors allows an easy aerial maintenance even at great heights.

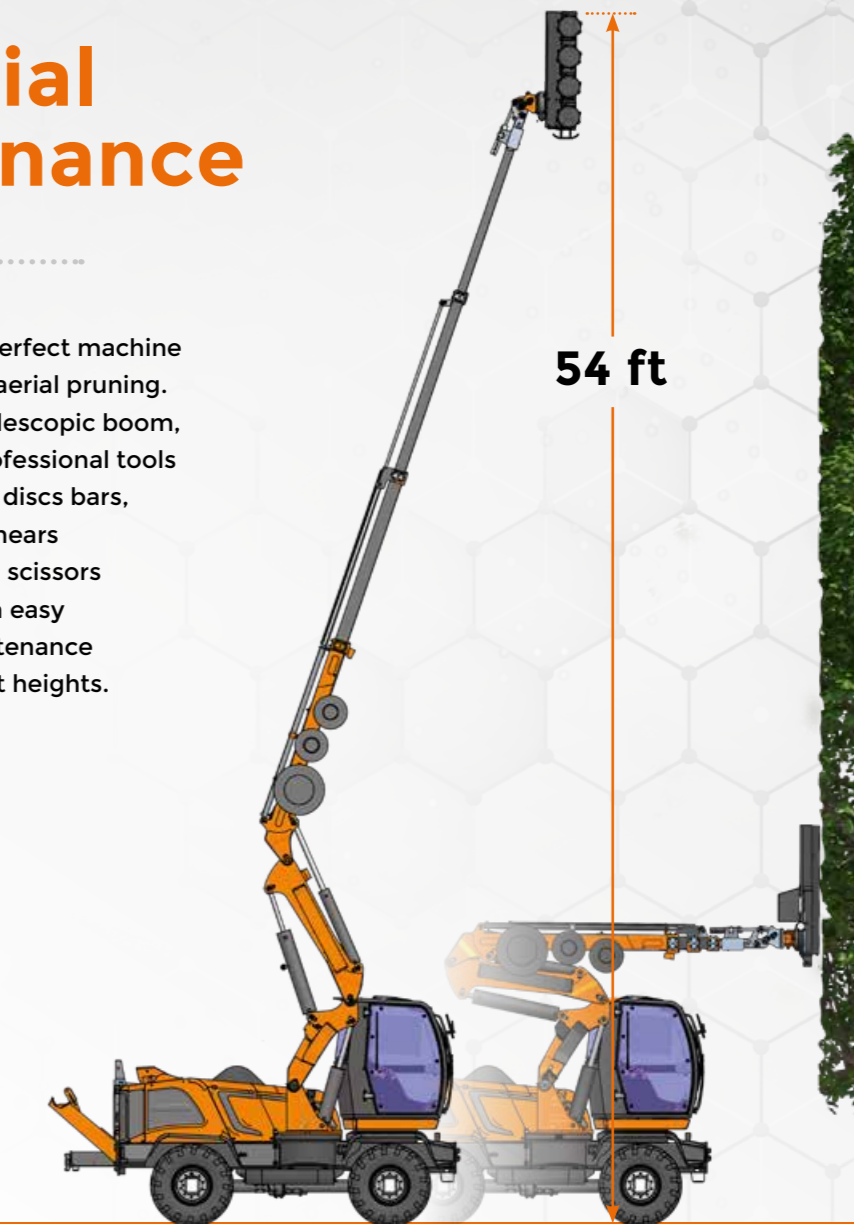





# ACCESSORIES

**A** FRONT ATTACHMENT



LIFTER "HERCULES" (10 T.)  
*(optional)*



DIN PLATE 76060  
*(optional)*

**B** REAR ATTACHMENT











BLOWER  
*(optional)*



TOW HOOK

## ATTACHMENTS

THE SUITABLE TOOL FOR EVERY JOB

<p><b>C</b></p>  <p><b>NEW SPEED</b> 47" FLAIL HEAD</p>	 <p><b>NEW SPEED</b> 59" FLAIL HEAD</p>	 <p><b>CONVEYOR HEAD</b> FLAIL HEAD WITH CONVEYOR BELT</p>	 <p><b>FORESTRY HEAD</b> FORESTRY HEAD WITH FIXED TEETH</p>	<p><b>A</b></p> <p><b>RAIBER</b> BARRIER MOWER</p>  <p><b>TRANSFORMER 840</b></p>
 <p><b>SAW BAR</b> CUTTER DISCS BAR</p>	 <p><b>CUTTER BAR</b></p>	 <p><b>POWER SHEARS</b></p>	 <p><b>IRON BRUSH</b></p>	 <p><b>DISCOVERY 840</b></p>
 <p><b>DITCH CLEANER</b></p>	 <p><b>ORANGE PEEL GRAPPLE</b></p>	 <p><b>TRUNK PINCERS</b></p>	 <p><b>FORC-ONE</b></p>	 <p><b>ROTATOR UNIT</b> ROTATOR UNIT FOR 180° ATTACHMENT ROTATION</p>
 <p><b>EXTRA TRUNK</b> PRUNING SCISSORS-PINCERS</p>	 <p><b>STUMP GRINDER</b></p>	<p>Only for 3P boom</p>  <p><b>RIVER BUCKET</b> WEEDING-MOWING BUCKET</p>	 <p><b>DITCH BUCKET</b></p>	

ATTACHMENTS



# AGILITY

## Agility and Accuracy in the Movements

The multifunction soul of this machine is highlighted also from the 4-wheel drive traction system, all steering, hydraulically configurable from the cab control in 3 different operating modes:

- **2 front steering wheels**, for the maximum agility on road movement.
- **4 steering wheels**, a system that halves the turning range of the machine, ideal for working in narrow areas.
- **4 parallel steering wheels (crab)**, useful for moving special tools or for moving away from an obstacle.



2 STEERING WHEELS



4 STEERING WHEELS CONCENTRIC



4 STEERING WHEELS PARALLEL



# STABILITY

## Stability Control Device

The **Stability Control Device** allows to lock the front axle oscillation, increasing the stability of the machine, in order to guarantee the maximum level of performance and safety for the operator. This plus is composed by two hydraulic jacks fixed on the chassis of the machine and controlled by the operator inside the cab.

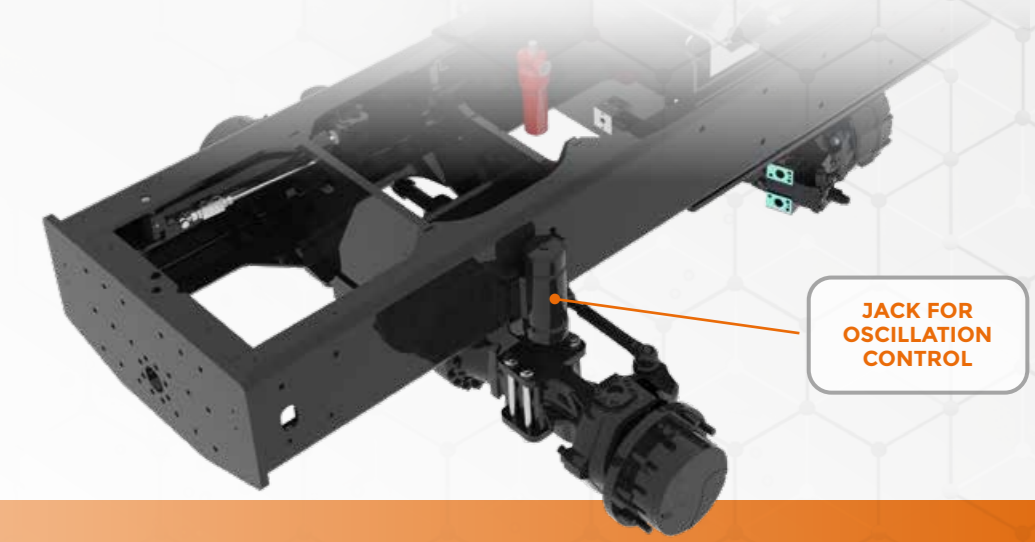
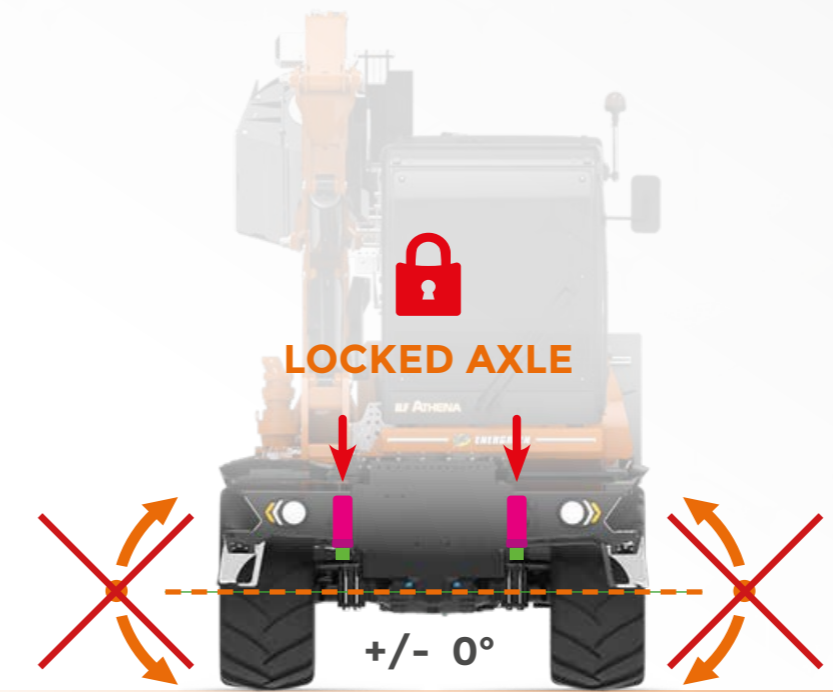
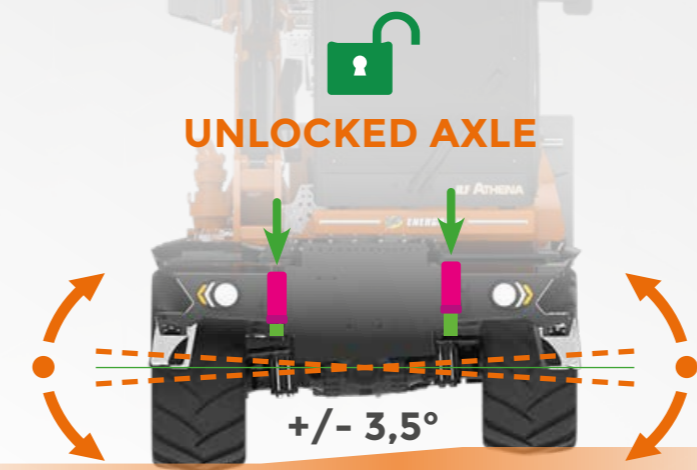



OPTIONAL



### AUTO LUBE Automatic greasing system OPTIONAL

The **AUTO LUBE** system is built with an electric greasing pump, electronically controlled, that allows to work independently and to be programmed to ensure the best grease of pins and bushing of the boom and of hydraulic cylinders. Moreover, this system allows an important reduction of maintenance hours.



### JOYSTICK Simple and intuitive

High quality joystick with proportional main controls that allows a precise and smooth control of the attachments. It allows to move up to 3 boom functions at the same time with an excellent gradual movement.

# TIRES



WIDE RANGE  
OF TIRES  
FOR EVERY TYPE  
OF GROUND  
AND JOB

STANDARD

MICHELIN  
XF 18  
445/70  
R 22.5



FOR  
ON-ROAD  
AND  
OFF-ROAD  
ACTIVITY

OPTION A

TRELLEBORG  
T440  
650/45  
R 22.5



IDEAL FOR  
OFF-ROAD  
ACTIVITY,  
RADIAL TIRE

OPTION B

ALLIANCE  
380 HD  
600/50  
R 22.5



IDEAL FOR  
ON ROAD  
ACTIVITY



# ENGINE

## ILF ATHENA

## DEUTZ Power Engine



ILF Athena is equipped with a Deutz 6.1 220 HP 6-cylinder inline engine with liquid-cooled, external exhaust gas recirculation and EPA Tier 4f emissions.

The powerful DEUTZ Common Rail injection system with high pressure with 2 valves per cylinder and the electronic engine control (EMR) with intelligent link to the drive management ensure optimum engine performance at low fuel consumption.

- Minimum consumption of operative liquids compared to competitors.
- Technical support and diagnosis provided by DEUTZ's worldwide service network.

THE ENGINE COMPARTMENT IS EASILY ACCESSIBLE FOR MAINTENANCE



**FIVE INDEPENDENT HYDRAULIC SYSTEMS:**  
1. MOVEMENT  
2. FLAIL HEAD  
3. STEERING  
4. BRAKING  
5. BOOM FUNCTIONS

INLET HIGH PRESSURE FILTER TO THE DISTRIBUTOR

OSCILLATING FRONT AXLE

JACK FOR OSCILLATION CONTROL

FIXED REAR AXLE

HD-FRAME IN STREX®

4 WHEEL DRIVE\*  
\* Disengageable

HYDROSTATIC TRANSMISSION

NEGATIVE PARKING BRAKE (REAR AXLE)

100% FRONT AND REAR DIFFERENTIAL LOCKING

BRAKE DISCS IN OIL BATH ON BOTH AXLES

# QUALITY

# DEUTZ 6.1





Adjustable steering column



Two-seater cabin



Power track



Proportional distributor Joystick



Steering wheel with multifunction display



Deutz 6.1 220 HP EPA Tier 4f engine



FLEXXAIRE® self-cleaning reversible fan



Integrated step

### CABIN

Cabin	Rotating un to 90°
Multifunction display	Steering wheel integrated
Steering wheel	Adjustable
Joystick	Electronic
Rotary lamp	Switch inside the cabin
Air conditioning	Electronic
Rear glasses	Darkened anti UV
Cabin door	Partially openable
Adjustable seat	Air suspension
Power socket	12 V
Battery switch	Automatic
Cabin homologation	FOPS-ROPS

### ENGINE

Brand	Deutz 6.1
Type	6 Cylinders Diesel
Power	220 HP
Injection	Common Rail DCR
Emissions	EPA Tier 4f
Alternator	150 A
Pre-heating air engine intake	
Air intercooler radiator	
Computer for visualization engine data	
Self-cleaning reversible fan	FLEXXAIRE
Fuel tank capacity	83 gal
AdBlue capacity	8 gal

### HYDRAULIC SYSTEM

Pumps and motors in closed circuits	
Flail head pump	Piston
Translation pump	Piston
Pumps and motors in open circuits	
Boom movement ( LS )	Piston
Brakes system	Gear
Steering system	Gear
Hydraulic distributor	Electronic and proportional
Oil flow for attachment	42 gal/min
Oil pressure for attachment	290 bar

### TRASMISSION AND BRAKES

Transmission	Hydrostatic
Traction	4 x 4 (disengageable)
Speed variation	0 - 24 mph (continuous)
Manual gearbox	2 gears
Wheel alignment	Electronic
Front axle	Oscillating
Front axle block	Hydraulic
Steering axles	2 axles
Axle block	Front 100%
	Rear 100%
Parking brake	Negative
Service brakes	6 discs for axle

### DIMENSIONS AND WEIGHT\*

A Lenght	231 in
B Height	157 in
C Width	94.7 in
D Wheelbase	110 in
Machine weight without attachment	40000 lb
Cutting head (59") + rotator unit weight	1124 lb

\* Dimensions with standard tyres.

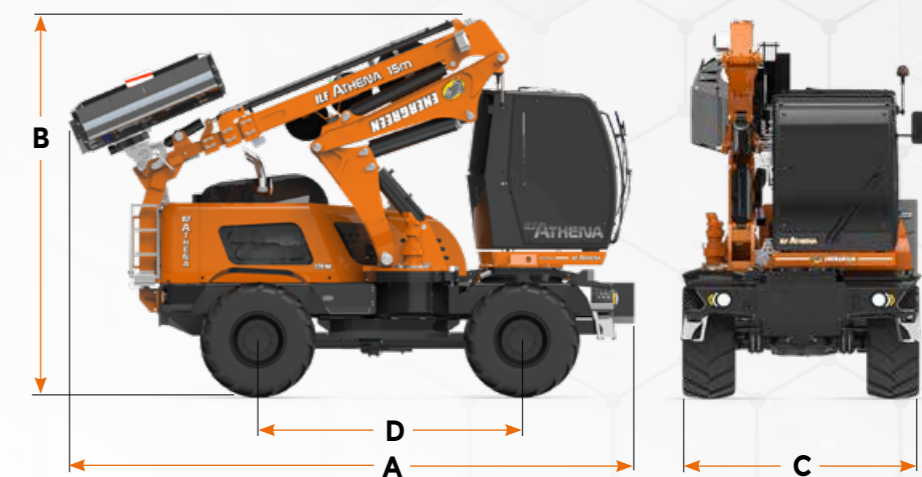

## OPTIONAL



Led working light kit



Cabin porthole



Backup camera



Movable weight with step

Technical and construction specifications may be subject to change without prior notice.





**ILF ATHENA**



**ENERGREENAMERICA.COM**



# SELF-PROPELLED HYDROSTATIC MACHINES



Local dealership



ENERGREEN America · 227 Trade Ct. · Aiken · SC 29805 · USA  
Phone 470 989 2600 · info@energgreenamerica.com  
www.energgreenamerica.com

PROFESSIONAL MACHINES AND ATTACHMENT



ELUSDP1500102 - 0124 - © Energgreen America 2024 - All rights reserved  
Photo, technical and constructive characteristics subjected to modification without reporting requirement.