

*Robo***FIFTI** 50HP



ENERGREEN[®] *America*
Professional Machines 

REMOTE
CONTROLLED
TOOL
CARRIER

55 SLOPE



**REMOTE CONTROLLED
TOOL CARRIER**



ROBOFIFTI

New Remote Radio-Controlled Tool-Carrier

*Robo***FIFTI** 50HP



RoboFIFTI is a remote-controlled tool-carrier machine able to work in the narrowest areas, on slopes up to 55° or where the access is very difficult.

This robot is equipped with a powerful **50 HP EPA Tier 4 F diesel engine** and two double effect hydraulic functions.

Extremely flexible, it is able to mount different equipment like grass or forestry head, stump grinder, bucket and many more.

Power, reliability, and safety differentiate the radio-controlled robot **RoboFIFTI** from the other professional radio-controlled machines.

 **WORKING RANGE 492 FT**

STRENGTHS



Safety and Comfort

- Radio controlled machine
- Operator in safety zone
- Emergency button on remote control
- Excellent handling
- Easy to use and carry



Working on steep slopes

- Excellent grip in all directions up to 55°
- Exclusive tracks design with large bearing surface
- Special oil sump
- Low center of gravity

Robo*FIFTI*
50HP



STRENGTHS



Multifunction

- Multiple tools available
- Road and river maintenance
- Green maintenance and forestry work
- Agriculture and industry service
- Winter road service



Productivity

- Engine 50 HP EPA Tier 4 F
- Quick change of attachments
- Fast execution of work
- Reduced consumption
- Maneuverability on any surface

SLOPE **55°**



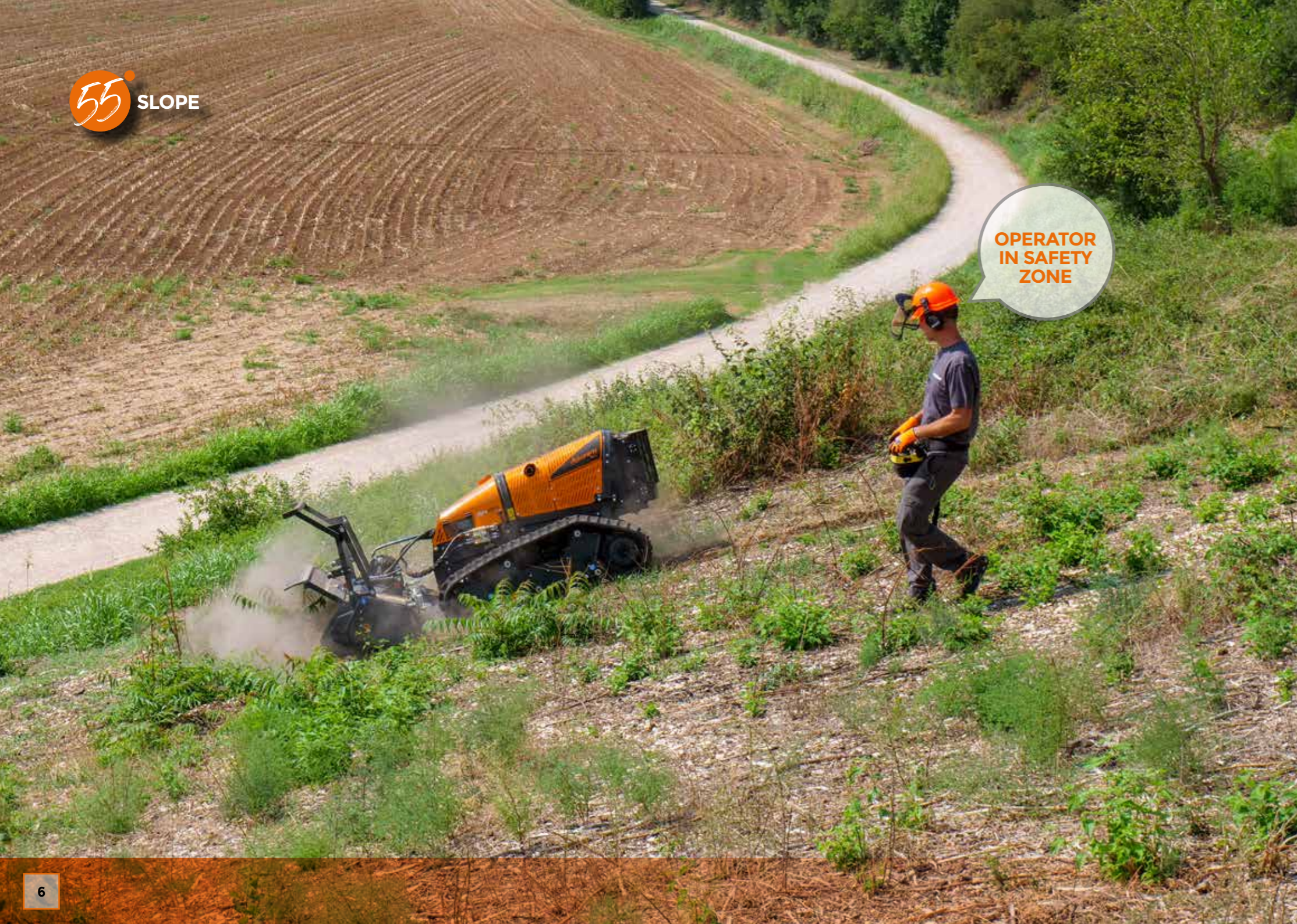

OPERATOR
IN SAFETY
ZONE

REMOTE CONTROLLED

RoboFIFTI
50HP

THE **REMOTE CONTROL**
IS LIGHTWEIGHT, INTUITIVE,
AND EASY TO MASTER

RoboFIFTI is Safety

RoboFIFTI is a remote-controlled machine, able to work in **complete safety** in **dangerous areas**, with slopes up to 55° in any directions.

The low center of gravity and rubber or steel tracks assure excellent stability and grip even in the steepest situations.

With the radio-controlled machine **RoboFIFTI** the operator works in full safety: the working range of the remote-control reaches **492 ft** avoiding the exposition to noise, vibration, exhaust gas, object projection that could compromise the safety of the working activity.

EMERGENCY
BUTTON



492 FT

RoboFIFTI 50HP



QUALITY COMPONENTS ✓

RoboFIFTI is built in an ultra-resistant steel to ensure a long duration; all the components are tested and certified to ensure the maximum reliability and safety.

- Engine tested by the producer with a remarkable reputation for reliability.
- Remote-control technology developed by a team of specialized experts.
- Powerful and efficient engine, appropriate for steep slopes.
- Engine crankcase designed to ensure the grease, even on steep slopes.
- Independent cooling system of the hydraulic system to optimize performances.
- Double roll bar integrated into the frame to ensure a total protection of the machine.
- Flat bottom frame to protect the parts of the engine.
- Fully enclosed body panels keep out grass and debris.
- Front lifter with quick attachment mounting system.

Born to satisfy the most difficult needs, RoboFIFTI can easily be defined as a remote-controlled grass cutting machine with power and performances comparable to a traditional grass cutting boom for tractors.

Power, reliability, strength and performance are the fundamental features that distinguish this machine from any other robots in the market.



RoboFIFTI is equipped with the self-cleaning reversible fan FLEXXAIRE® to increase productivity and fuel saving.

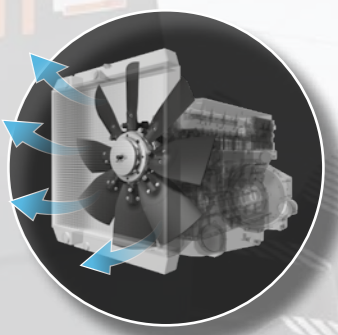

50 HP EPA TIER 4 F PERKINS ENGINE

THE BEST COMPONENTS

FREXXAIRE® SELF-CLEANING REVERSIBLE FAN



WORK ON SLOPES

Working on steep slopes up to 55°

The **exclusive tracks profile** by Energreen and the **tensioning hydraulic system** guarantee a larger ground contact surface.

RoboFIFTI is a safe machine for working on slopes up to 55° in each direction and in every environment context such as hills, mountains, riverbanks, or cliffs.

Generally, the radio-controlled machine **RoboFIFTI** is suitable to all the situations with steep slopes and low adherence.



RoboFIFTI

LOWERED CENTER OF GRAVITY

55°

LOWERED CENTER OF GRAVITY

ENGINE

RoboFIFTI 50HP



50 HP Power Engine

RoboFIFTI is equipped with a 50 HP (36 kW) Perkins engine with 3-cylinder in line with liquid-cooled, external exhaust gas recirculation and EPA Tier 4 F emissions.

Perkins is an expert of the sector with more than 85 years of experience in the engine fields. The engine is compact and highly technologic, able to satisfy the most demanding needs of power, assuring low management costs.

The aspiration is turbocharged, and the combustion system has direct injection to maximize performance. A new radiator and a new oil pin assure stability and safety.

EASY ACCESS FOR MAINTENANCE



PERKINS



OPTION A

RUBBER TRACKS

IDEAL TRACKS FOR DELICATE SURFACES

- 10" of width
- Excellent adherence to the ground
- Work on sloping areas up to 40°



OPTION C

SUPER RUBBER TRACKS

IDEAL TRACKS FOR ROCKY SURFACES OR FREQUENT MOVEMENTS

- 11" of width
- Wide supporting surface with consequent less weight per sq in
- Work on sloping areas up to 55°



OPTION B

STUDED TRACKS

IDEAL TRACKS FOR EXTREME SLOPES OR AREAS WITH DENSE VEGETATION

- 10" of width
- Work on sloping areas up to 55°
- Steel stirrups



OPTION D

STUDED TRACKS AND SPIKES

IDEAL TRACKS FOR EXTREME SLOPES OR WET SURFACES

- 10" of width
- Work on sloping areas up to 55°
- Steel brackets and spikes
- Rubber head flaps (removable)



RUBBER BUFFERS

MULTIFUNCTION

The suitable tool for every job

RoboFIFTI is a technologically advanced machine that responds to the current needs of safety and performance requested by the market.

Energreen, with its range of Robo machines, wants to change the traditional concept of grass cutting and other kinds of works, creating a remote-controlled machine, that can do operations of mowing where previously there was only the possibility to use hand brush cutters.

This represents a new frontier of use, where the safety of the operators is put in first place. RoboFIFTI is certainly faster than the traditional ways of mowing optimizing the work in the most different working environments.



MULTIFUNCTION

Front lifter with quick attachment

RoboFIFTI is a remote-controlled tool-carrier machine equipped with a dedicated lifter which allows a quick-change system, making the work easier and multifunction.

Lifter and hydraulic connections allow the perfect match with all the previous and current attachment provided by Energreen.



CONNECTION LEVER

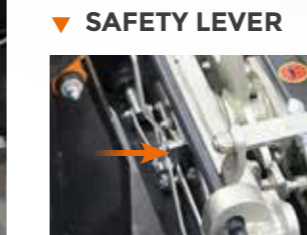

SAFETY LEVER



ATTACHMENT PIN





1.2"



HEAD 130 MULCHER HEAD

Strong and reliable mulcher head, with a frame made of high resistance Strenx® steel, wear-proof and shock-proof. The head is the ideal solution to cut grass and shrubs up to a diameter of 1.2". It can be equipped with a rotor with hammers or with Y flails.

TECHNICAL DATA

Cutting width	49 in
Pressure	4351 PSI
No. of tools	22 (Y flails) / 26 (Hammers)
Oil flow	14.5 gal/min
Hydraulic motor	1.4 HP
Weight	440 lbs



1.2"



HEAD 155 MULCHER HEAD

Strong and reliable mulcher head, built in Strenx® steel, ideal for cutting grass and shrubs, up to a diameter of 1.2". It is equipped with a Y-shaped knives rotor with adjustable height of cutting.

TECHNICAL DATA

Cutting width	60 in
Pressure	4351 PSI
No. of tools	30
Oil flow	14.5 gal/min
Hydraulic motor	1.4 HP
Weight	683 lbs



2.4"



FORESTRY 130 H FORESTRY HEAD WITH SWINGING HAMMERS

Strong and reliable forestry head, with a frame made of high resistance Strenx® steel, wear-proof and shock-proof. It is the ideal solution to cut grass and shrubs up to a diameter of 2.4". It is equipped with a rotor with swinging hammers.

TECHNICAL DATA

Cutting width	51 in
Pressure	4351 PSI
No. of tools	22
Oil flow	14.5 gal/min
Hydraulic motor	1.5 HP
Weight	783 lbs



4"



FORESTRY 130 T FORESTRY HEAD WITH FIXED TEETH

Strong and reliable forestry head, with a frame made of high resistance Strenx® steel, wear-proof and shock-proof. It is the ideal solution to cut grass and shrubs up to a diameter of 4". It is equipped with a rotor with fixed teeth.

TECHNICAL DATA

Cutting width	46 in
Pressure	4351 PSI
No. of tools	32
Oil flow	14.5 gal/min
Hydraulic motor	1.5 HP
Weight	860 lbs



STUMP GRINDER

With an oscillating arch movement, this powerful stump grinder can trill an entire stump or trunk. In this way it is possible to renovate areas as a garden or a field even on slopes.

TECHNICAL DATA

Cutter disc diameter	16 in
Rotation wheel	2000 rpm
No. of teeth	16
Pressure	4206 PSI
Oil flow	14,5 gal/min
Weight	265 lbs



ROTARY MOWER

Rotary turf mower designed to to finely grind and mince the grass and then leave it on the ground, not collecting it. In this way the cutted grass acts as natural fertilizer bringing numerous benefits for the turf and optimizing costs. Also available with rear exhaust pipe.

TECHNICAL DATA

Cutting width	59 in
Cutting height	0,3 / 2,8 in
No. of knives	3
Pressure	4206 PSI
Hydraulic motor	1,4 HP
Weight	463 lbs

Technical and construction specifications may be subject to change without prior notice.



CUTTER BAR

Lightweight and handy cutter bar equipped with teeth made of Carbodux®, wear-proof. It is useful for cutting the fresh grass or the hay of pastures that can so be collected to be dried and then stocked, making the fodder process easier.

TECHNICAL DATA

Type	FK-170	FK-200
Cutting width	67 in	79 in
Pressure	1450 PSI	1450 PSI
No. teeth	24	26
Side shift	13° right-left	13° right-left
Hydraulic motor	3 HP	3 HP
Weight	480 lbs	507 lbs



RAKE

Tedder rake designed to turn around and air the hay previously cut. In this way the dry process is faster: the hay can be collected and stocked to feed animals. It can be also used along rivers or canals to cut the grass on riverbanks.

TECHNICAL DATA

Working width	63 in
Rotation speed	220 rpm
Side shift	+/- 13°
Pressure	2900 PSI
Hydraulic motor	16,6 HP
Weight	278 lbs

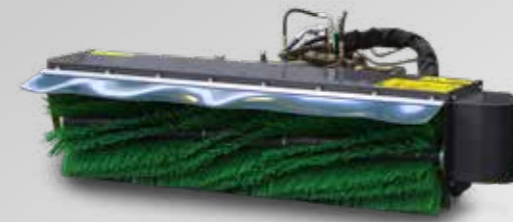

BRUSH SWEEPER

Sweeper used to clean the surface from various types of debris. It is equipped with hydraulic cylinders to adjust the lateral shift. It can also be equipped with a bucket for the collection of the material (optional).

TECHNICAL DATA

Working width	59 in
Brush diameter	16 in
Wheel rotation	650 rpm
Side shift	+/- 20°
Hydraulic motor	5.3 HP
Weight	330 lbs



FORKS

Robust steel forks, 32" long, useful for the handling of various types of goods placed on pallets, up to a maximum weight of 660 lbs.

TECHNICAL DATA

Max forks width	35 in
Forks length	31 in
Class forks	1-ISO 2328
Loading capacity	660 lbs
Pressure	2610 PSI
Weight	176 lbs



BUCKET TIPPING BUCKET

Bucket for cleaning narrow areas as passages, galleries, tunnels with reduced height where it is not possible to work with traditional machines. Two hydraulic cylinders allow to load the product from a height of 26" for a working width of 51".

TECHNICAL DATA

Working width	51 in
Max. tipping height	26 in
Loading capacity	661 lbs
Bucket volume	7 ft³
Pressure	2610 PSI
Weight	551 lbs



GRAPPLE BUCKET

Bucket equipped with a grapple with nine teeth made of steel avoiding the fall of material. The mouth opening is actioned thanks to a hydraulic jack. It is useful for transport waste, rubbish and vegetation in general.

TECHNICAL DATA

Working width	52 in
Max. tipping height	24 in
Loading capacity	661 lbs
Bucket volume	5,3 ft³
Pressure	2610 PSI
Weight	551 lbs

Technical and construction specifications may be subject to change without prior notice.

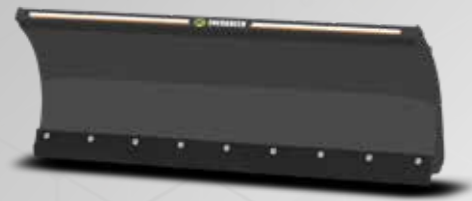

LAND BLADE

Land blade made of steel, useful for the maintenance of roads, streets, avenues, squares and the removal or transfer of waste, foliage and other kind of material.

TECHNICAL DATA

Blade width	67 in
Blade height	16 in
Blade material	Steel
Inclination degree	+/- 20°
Side shift degree	+/- 13°
Weight	308 lbs



TRENCHER

Trencher useful for digging activity on vegetal soil or compact grounds. It is useful in agriculture, for instance, to dig little canals to create irrigation systems.

TECHNICAL DATA

Digging depth	39 in
Digging width	5/6/8 in
Length	83 in
Width	34 in
Pressure	3480 PSI
Weight	573 lbs



ROTARY TILLER

Rotary tiller built with a frame made of steel and equipped with a protection on the upper part. The tiller is excellent to plough and stump the soil in hilly locations.

TECHNICAL DATA

Working width	57 in
Max. length	63 in
Max. working depth	6 in
No. of tools	28
Power	22 HP
Weight	386 lbs



ROTARY HARROW

This tool is useful for different works on the soil: break clumps, prepare the soil for seeding, plough, bury the fertilizer. It is equipped with a roller and a two knives rotor.

TECHNICAL DATA

Working width	59 in
Max working depth	7 in
No. of tools	14
No. of rotator	7
Power	32 HP
Weight	551 lbs



SPRAYER

This agriculture sprayer is useful for antiparasitic or fungicide treatments to avoid diseases and molds. It can be equipped with the weeding bar and a reel with handgun.

TECHNICAL DATA

Capacity	53 gal
Fan diameter	22 in
Power	13 HP
Flow	18 gal/min
Air volume	10 in ³ /h
Weight	838 lbs



BIO-SHREDDER CHIPPER

Powerful chipper designed to shred group of branches, trunks, or vegetal waste with a diameter up to 3.5". The chopped material can be ejected directly on the soil or collected for the transport.

TECHNICAL DATA

Max chipping diameter	3,5 in
Output	247 ft ³ /h
Hopper opening	15,7 x 27,5 in
Hydraulic motor	1.4 HP
Power	27 HP
Weight	474 lbs



3.5"

Technical and construction specifications may be subject to change without prior notice.

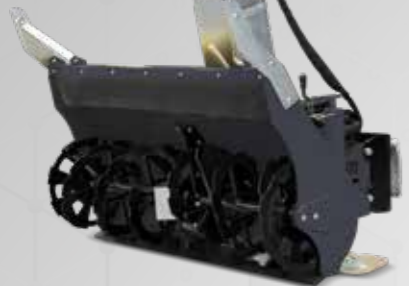
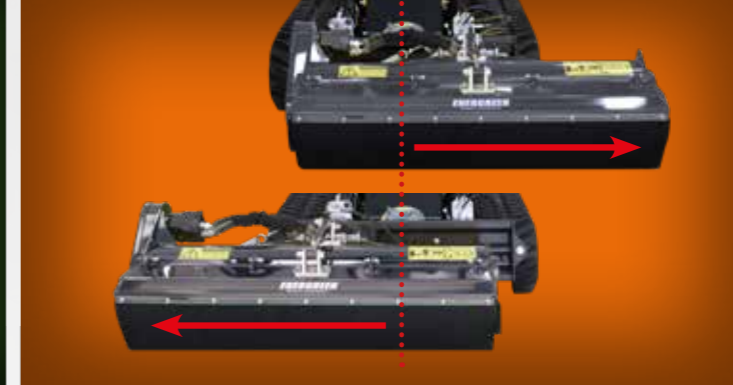
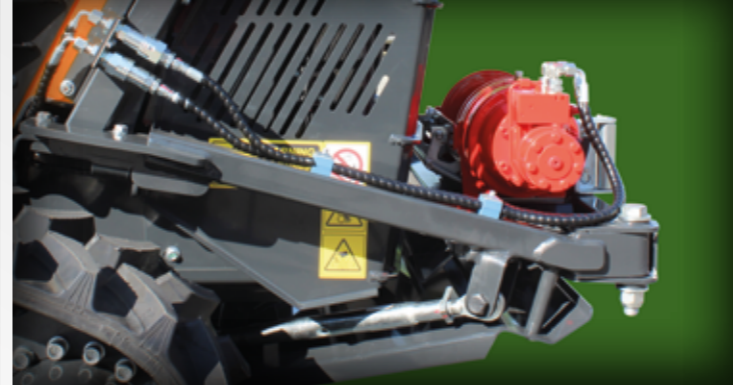

SNOW BLOWER

Blower designed to remove the snow, both soft and frozen along roads and in narrow areas or in locations difficult to reach. The chimney is made of zinc steel, hydraulically adjustable and can reach a rotation angle of +/- 100°.

TECHNICAL DATA

Working width	55 in
Working height	27,5 in
Cutter diameter	16 in
Hydraulic motor	4 HP - 3626 PSI
Chute rotation	+/- 100°
Weight	617 lbs



SNOW BLADE

Tool with plastic or steel blade, hydraulically adjustable, ideal for cleaning and removing the snow from roads, open spaces, parks even on slopes. In the lower part it is equipped with a scraping blade that is easily interchangeable through bolts.

TECHNICAL DATA

Blade width	67 in
Blade height	23 in
Blade material	PVC or steel
Inclination degree	20°
Side shift	+/- 13°
Weight	271 lbs



UMBRELLA INTERCEPTATIVE UMBRELLA

Interceptative umbrella used for harvesting olives and tree fruits. The special design of the net can embrace plants with a single trunk or more.

TECHNICAL DATA

Diameters	18 ft - 21 ft - 25 ft
Diameters telescopic	(18-25 ft) - (21-25 ft) - (21-28 ft)
Maximum slope	50°
Maximum diameters tronco	39 in
Capacity	330 lbs
Weight	771 lbs



WINCH

Hydraulic winch, useful for towing the machine in case of need. Has a towing capacity of 3086 lbs, which added to the power of the machine increases its strength to ensure maximum reliability.

TECHNICAL DATA

Pulling force	3086 lbs
Hydraulic flow	3,7 gal/min.
Drum rope length	105 ft
Diametro fune - Rope diameter	0,3 in
Pressione di traino - Towing pressure	2610 PSI
Peso (con supporto) - Weight (with support)	330 lbs

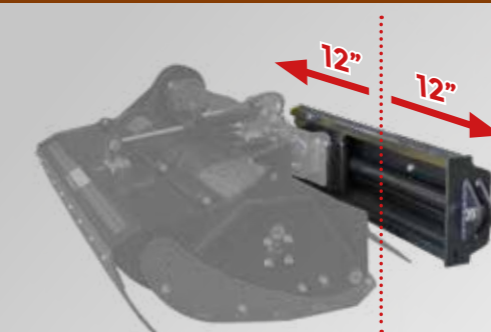

SIDE-SHIFT HYDRAULIC SIDE-SHIFT

This application allows the lateral shift (right and left) of the mulcher head.

TECHNICAL DATA

Translation right	12 in
Translation left	12 in
Width	35 in
Height	20 in
Weight	148 lbs



FORESTRY WINCH

Professional forestry winch ideal for moving trunks and plants in the wood or in the countryside, on steep slopes or in narrow areas.

COMING
SOON



AVAILABLE ATTACHMENTS



TRIMMY BOOM

This boom can reach an extension up to 138" in depth and 177" in height, therefore working in uncomfortable situations or on steep slopes become job easy and safe.

TECHNICAL DATA

Available attachments	4
Max. length	138 in
Max. height	177 in
Oil flow rate	8 gal/min
Oil pressure	2320 PSI
Weight	474 lbs

FLAIL HEAD



HEDGE TRIMMER



BUZZBAR



BRUSH



OPTIONAL

OPTIONAL



Strong Radiator Protection

RoboFIFTI can be equipped with a rear steel protection for the radiator (optional). It is a solid structure made up of metal hoses and plates designed to limit damages in case of collision. The structure is handy and easy to open, making everyday maintenance much easier, thanks also to the possibility of lifting it and have an easy access to the radiator.

Radiator protection



Command board with 4,3" color display



Led lights

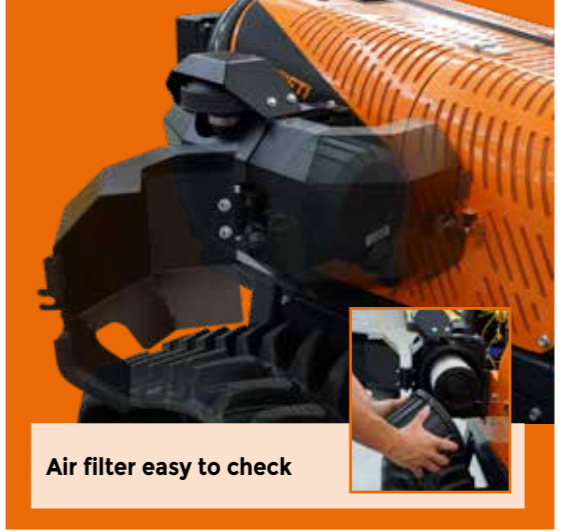

Air filter easy to check



Hydraulic tension of the tracks



50 HP EPA Tier 4f Perkins engine



Front lifter with quick attachment with safety lever (A)



Total protection design



Double roll bar integrated into the frame

OPTIONAL



CEJN quick hydraulic couplings

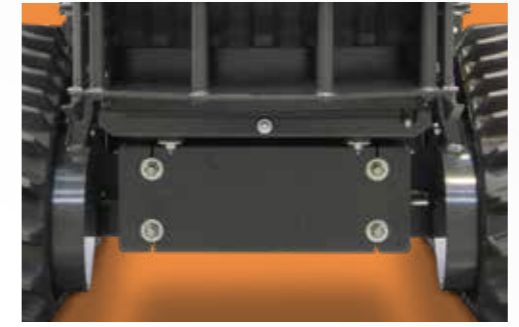

Rear weight - Comp. 154 lbs



Led light



Led flashing beacon

Technical and construction specifications may be subject to change without prior notice.



TECHNICAL DATA



* Super rubber tracks
** Standard or studded tracks

RoboFIFTI

Maximum gradient	55°
Transmission	Hydrostatic
Low range speed	0 - 2.50 mph
High range speed	0 - 4.35 mph
Machine Weight	2645 lb

ENGINE

Brand	Perkins
Type	3 Cylinders Diesel
Power	50 hp (36 kW) EPA Tier 4 F
Fuel tank	7,5 gal.
Working RPM	2800 rpm

REMOTE CONTROL

Brand	Autec
Radio frequency	915 Mhz
Working range	492 ft
Joystick	Proportional
Battery	Rechargeable



REMOTE CONTROL CASE
standard



Technical and construction specifications may be subject to change without prior notice.



*Robo***FIFTI**

f y i in **ENERGREENAMERICA.COM**



REMOTE CONTROLLED TOOL CARRIER



Local dealership



ENERGREEN America · 227 Trade Ct. · Aiken · SC 29805 · USA
Phone 470 989 2600 · info@energgreenamerica.com
www.energgreenamerica.com

PROFESSIONAL MACHINES AND ATTACHMENTS



ELUSD200102 - 0124 - © Energgreen America 2024 - All rights reserved
Photo, technical and constructive characteristics subjected to modification without reporting requirement.