



**ALL ACCESS  
EQUIPMENT**



**CMC**  
THE SPECIALIFT

**90HD+ ARBOR PRO**

TECHNICAL DATA SPECSHEET





## AERIAL | STANDARD

- 90 ft Working height
- Up to 50 ft lateral reach
- Double telescopic lower boom
- Triple telescopic upper boom
- 90° Independently articulating jib
- 180° Basket rotation (+/- 90° each way)
- 400° non-continuous boom rotation
- Wired control panel in basket with 2 joysticks with single handed capability, for all functions including booms, outriggers, track drive, automatic leveling, speed controls, and home function. Joysticks eliminate the need for a separate deadman switch.



## OUTRIGGERS | STANDARD

- Automatic outrigger self leveling
- Multi-position outriggers in wide/narrow footprints
- Four (4) specially designed sliding outrigger pads
- Heavy-duty outrigger piston protective covers



## CHASSIS | STANDARD

- Wireless remote control with color screen for all functions including booms, outriggers, track drive, automatic leveling, speed controls, and home function.
- Cable to connect wireless remote in case of a problem with the wireless system
- Radio remote control storage box and built in battery charger for radio remote lithium batteries
- Remote connection kit (All Access can connect to machine remotely if unsecured WiFi is shared with machine)
- Two (2) lithium batteries and built in charger for radio remote control



## TRACKS | STANDARD

- Black rubber tracks (set)
- Vertically and horizontally hydraulically adjustable tracks
- Ability to raise basket & jib up out of the way while driving the tracks



## POWER | STANDARD

- Kubota D902 diesel engine
- 24V Battery backup electric pump (intermittently use the 24V battery to operate all functions)



## PLATFORM | STANDARD

- Removable single man 24" x 24" fiberglass basket equipped with basket quick connect bracket and vinyl fiberglass bucket cover with tether



## OTHER | STANDARD

- 1 & 3 years warranty. 1 yr "bumper to bumper" and 3 yrs on certain components. Unlimited use hours.
- Detailed owners maintenance and use manual, including parts and service diagrams
- One (1) Fall arrest safety harness





**CHASSIS | OPTIONAL**

- Travel alarm
- Warning light
- 1 Custom paint color: Choice of more than 200 colors. \*No fluorescent or metallic colors\*
- 2 Custom paint colors: Choice of more than 200 colors. \*No fluorescent or metallic colors\*



**TRACKS | OPTIONAL**

- Non-marking grey tracks (replaces the standard black tracks)
- Track socks



**POWER | OPTIONAL**

- Hybrid: Kubota diesel + 200A lithium batteries
- Full lithium battery power with built in battery charger. Should be paired with option 0000110. Kubota diesel is removed
- Auxiliary 120V 20A plug in electric motor with charger for 12V battery. This is not a battery system. With this system, you can plug the machine in and use it on 100% AC electric power. This is in addition to the combustion engine



**PLATFORM | OPTIONAL**

- Hydraulic Tool Outlet in basket
- High pressure air/water hoses routed internally from the ground to the basket - 2900PSI
- 120V Electric outlet in basket with extension cord through the booms
- Additional basket: Removable two-man aluminum basket
- Additional basket: Removable single man aluminum basket 31.5" L x 23.6" W x 43.3" H. Basket support with wheels for easy handling is included
- Additional basket: Removable two man made in USA 24" x 48" fiberglass basket equipped with basket quick connect bracket. If you only want the 2 man fiberglass basket and not the standard 1 man fiberglass basket



**OTHER | OPTIONAL**

- Biodegradable hydraulic fluid (non-toxic, natural fluid. For extreme cold or sensitive locations)
- Ratchet straps (each. 4 are already included)
- Additional fall arrest aerial lift harness and lanyard kit including storage bag



**LITHIUM ION BATTERIES**



**NON-MARKING TRACKS**



**HYDRAULIC TOOL OUTLET**



**CUSTOM PAINT COLORS**





## TECHNICAL SPECIFICATIONS

### PERFORMANCE

Maximum working height.....	90'
Maximum side reach at 507 lbs.....	40'7"
Maximum side reach at 176 lbs.....	50'6"
Maximum weight load with standard basket.....	507 lbs
Maximum weight load with optional single man fiberglass basket....	350 lbs
Moveable Jib articulating range.....	90°
Turret rotation range.....	+/-400°
Basket rotation range.....	+/- 90°
Maximum slope to stabilize (deployment).....	19° (34%)
Height / Width tracks adjustment.....	7"
Maximum slope approach angle (front/engine).....	13° (24%)
Maximum slope approach angle (rear/basket).....	17° (32%)
Gradeability -- max. travel angle / slope*.....	19° (34%)
Gradeability -- max. travel cross hill.....	19° (34%)
Maximum crawler travel speed**.....	0 - 2.2 ft/s

\*This is the standard setting. The standard setting can be overridden to: 31° (60.1%)

\*\*3 speeds: Slow, Slow with Torque, Fast

### DIMENSIONS

Basket height (aluminum basket is removable, variations available) ...	43"
Basket width.....	27"
Basket length.....	48"
Total length.....	22' 3"
Length without basket.....	19' 10"
Height in transport position (tracks in).....	77"
Height in transport position (tracks extended).....	85"
Total width (w/o basket, tracks in).....	35"
Total width (w/o basket, tracks extended).....	55"
Free height from the ground.....	15"
Tracks (LxW).....	69" x 10"
Outrigger spread length in narrow position.....	21' 8"
Outrigger spread width in narrow position.....	8' 7"
Outrigger spread length in wide position.....	17' 1"
Outrigger spread width in wide position.....	14' 5"
Outrigger spread wide to narrow position.....	11' 9"
Outrigger foot diameter.....	9 1/2"

### WEIGHT

Total weight.....	9,025 lbs
Maximum outrigger foot pressure.....	75.1 lb/In2
Maximum track pressure.....	3.41 lb/In2
Maximum pressure in travel.....	146.85 lb/ft2
Maximum pressure in work (wide outrigger setup).....	26.22 lb/ft
Maximum pressure in work (narrow outrigger setup).....	39.12 lb/ft2
Maximum pressure in work (one side wide, one side narrow).....	31.54 lb/ft2

### Power

Kubota D-902 E3B diesel engine.....	21.6 HP
120V 20A plug in electric motor (optional)	
Lithium ion batteries (optional)	

\*Technical specifications are non-binding, in some cases are approximate, and are subject to change.





**DIAGRAMS**

\*Measurements are in feet and inches

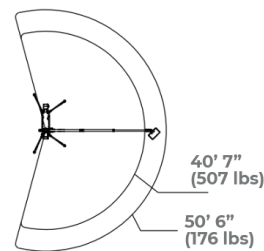
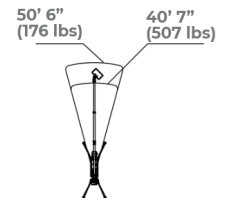
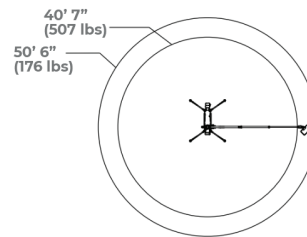
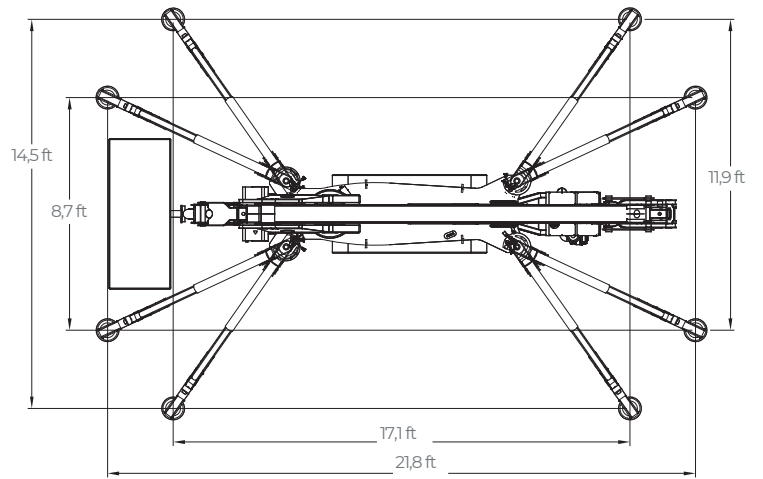
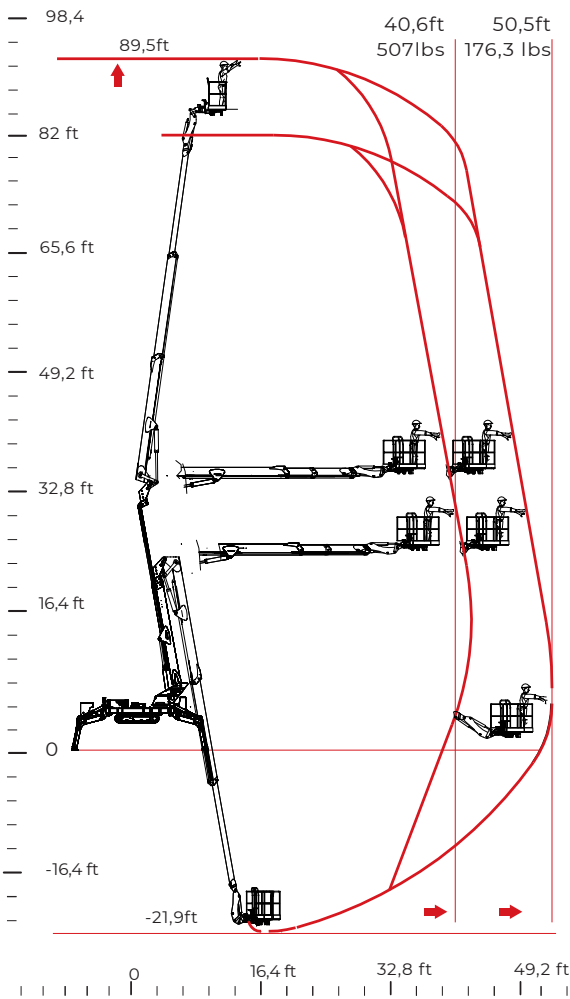
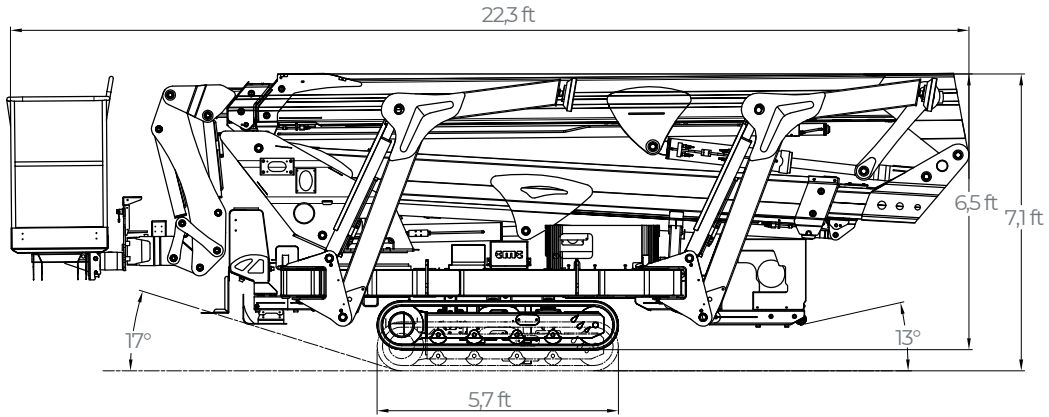

\*Technical specifications are non-binding, in some cases are approximate, and are subject to change.



**GALLERY**

