

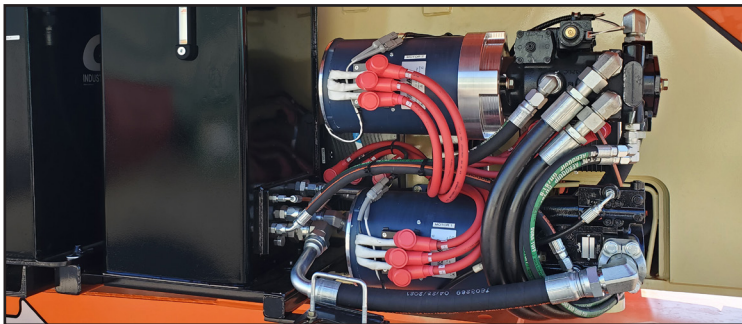

A80JCR CLEAN ROOM LIFT

Our next generation of man lifts are designed specifically to meet the requirements of clean rooms.

- The unit offers multi-shift capacity before charging with their high-capacity 96-volt battery assemblies.
- The lift is built to be highly serviceable and is constructed from off-the-shelf components.
- The learning curve and the chance of error are minimized by retaining an industry-standard user interface.
- The drive function is specifically designed and tuned to operate in the cramped environment of a clean room. The drive offers precise controls through a combination of motor controllers and hydrostatic drive control.



- High-efficiency three-phase electric motors are used to power the drive and boom functions.
- The boom functions are controlled by a separate motor and compensated axial piston pump that allows for the finesse of small motions and the demands of large flows with equal ease.
- An auxiliary pump and battery are included to ensure no one is ever stuck high in the air.

- The battery charger is a next-generation high-frequency fully programmable battery charger.
- The battery charger has the option of becoming part of a service network.
- We offer optional non-marking wheels as requested. These non-marking wheels are solid and increase the overall rigidity of the lift.



Specifications:

A80JCR	US	Metric
Platform Height	80 ft	24.38 m
Working Height	86 ft	26.38 m
Working Outreach	54 ft	16.45 m
Horizontal Outreach	52 ft	15.80 m
Swing	360° Continuous	
Platform Capacity - Unrestricted	500 lbs	226.8 kg
Overall Width	8 ft 2 in	2.49 m
Tail Swing	2 ft 6 in	.76 m
Jib - Range of Articulation	130°	130°

Range Diagram:

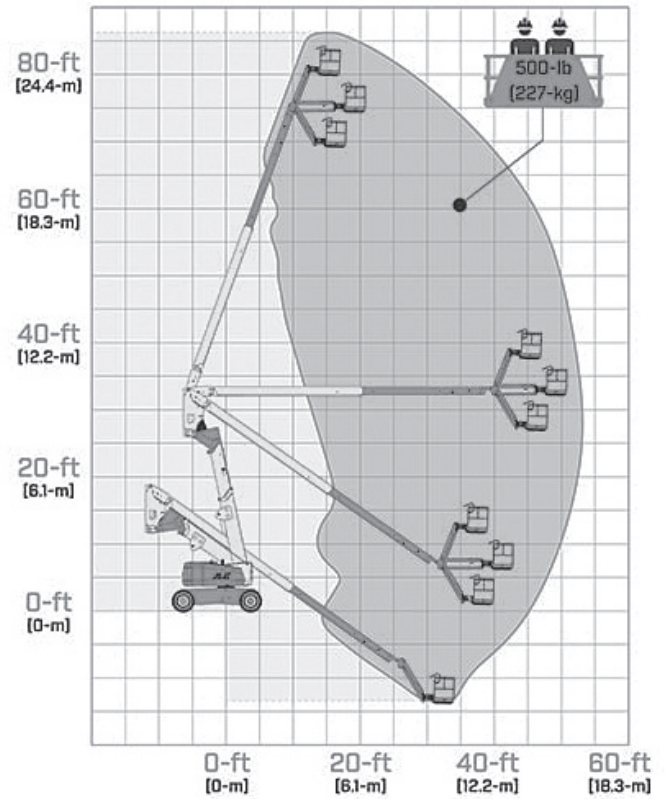

Dimensions:

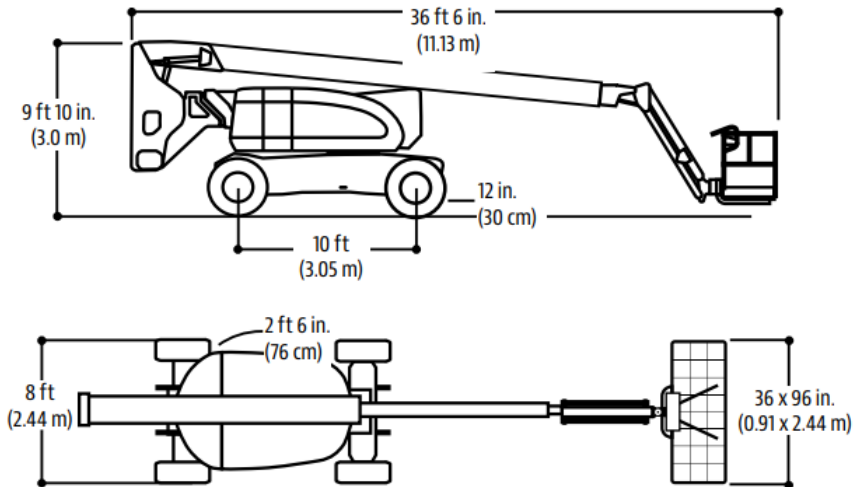

S81W18561 Gemini Drive, Muskego, WI 53150
262-710-4028 | www.BaileyCranes.com