

THE BRANDON™ OMNI

The World's Most Versatile Lifting Machine

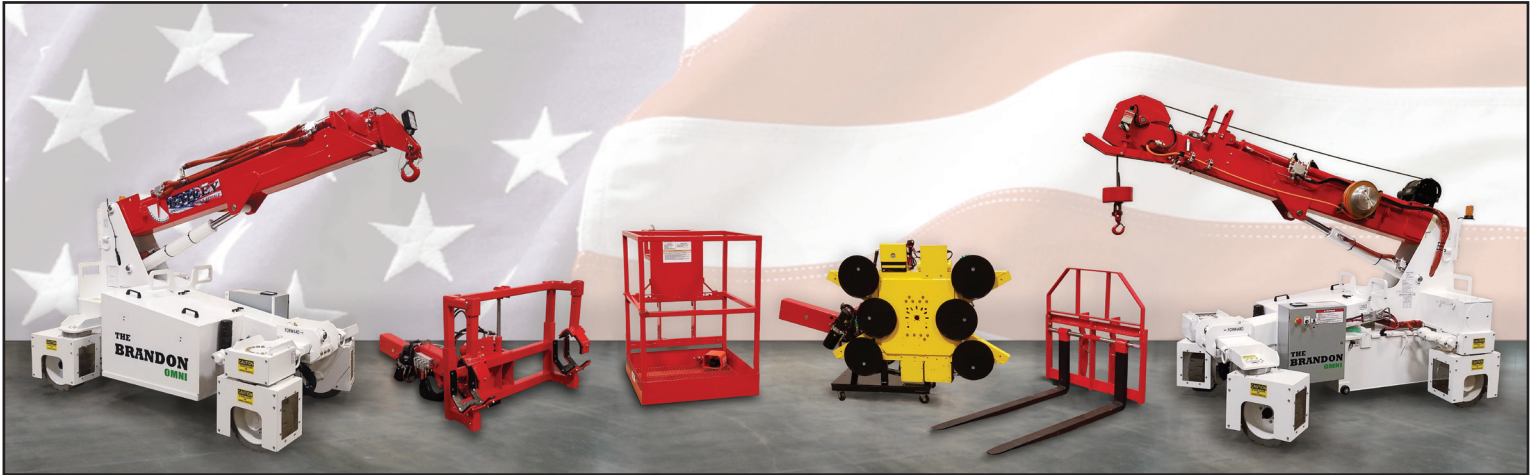

Model: Brandon Omni

Capacity: 4,000 lbs

Power: 36Volt 7HP Electric Motor

Steering: 2 Omni Directional Wheels

Drive: 2 Wheel Drive and Braking

Charger: On-board 110V

Weight: 5800 lbs + Attachment

Boom: Base unit, 2 telescoping booms and one manual pull-out boom. Attachments replace pull-out boom.

Rated Load Limiter: Displays rated load and actual load. Stops when overload is reached. Detects attachment and adjusts load parameters.

System Display: Includes Rated Load Limiter and system information

ISO 9001:2015 REGISTERED MANUFACTURING COMPANY

Omni-Directional Drive

Two Wheel Steer

Typical front wheel steering like an automobile

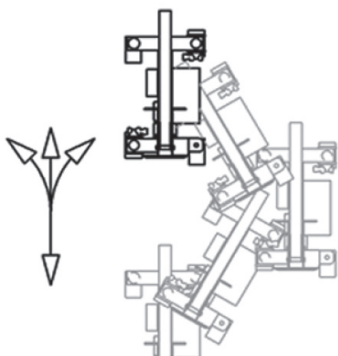

Spin Steer

Wheels rotate to a position so it rotates about its center

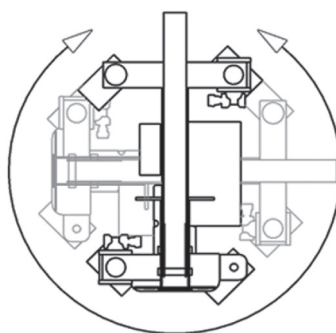

90° Crab Steer

Wheels rotate 180° to provide sideways travel

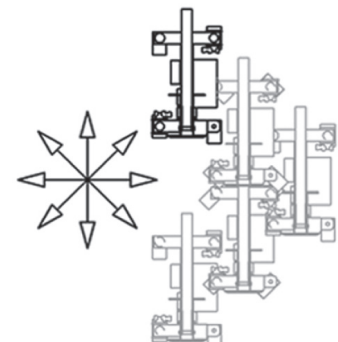

LOAD CAPACITY CHARTS

**** MULTIPLE PATENTS PENDING ****

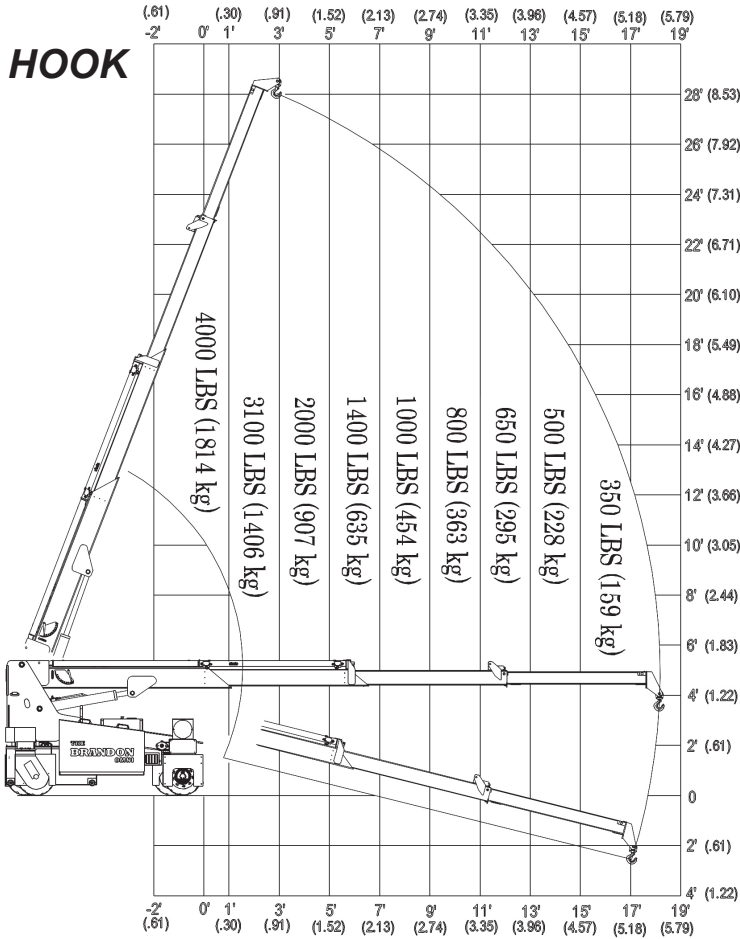

MODEL OMNI

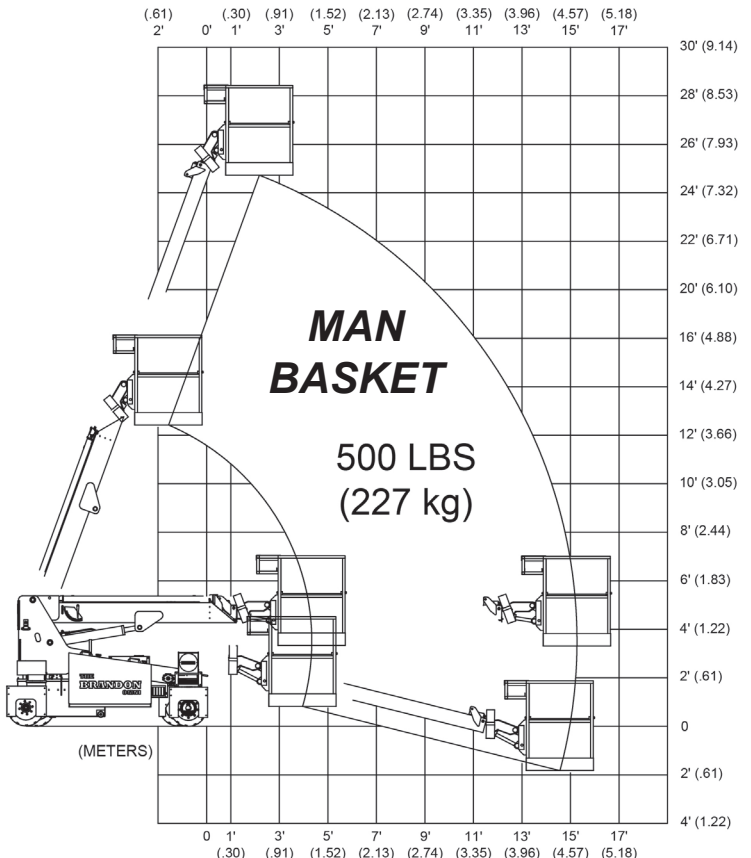
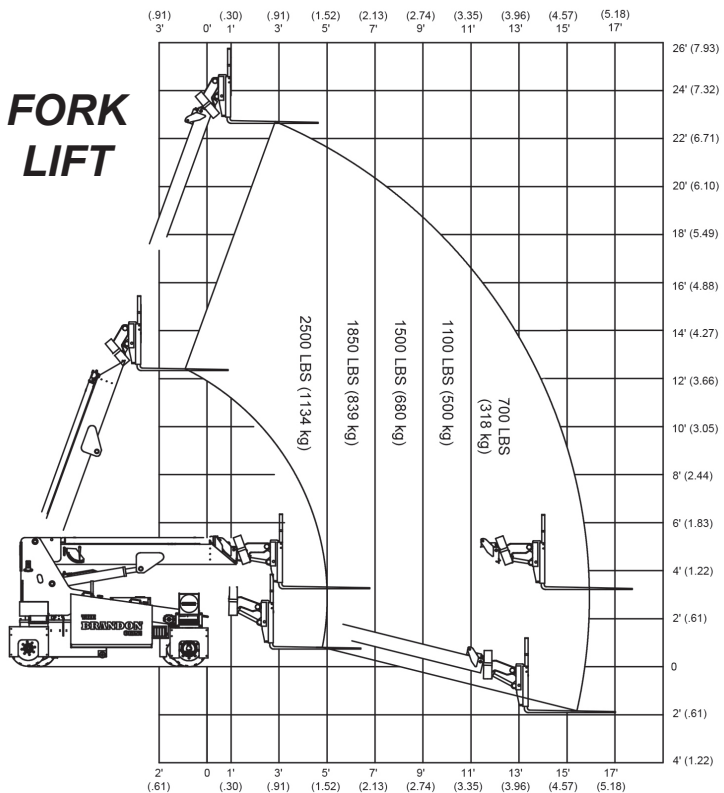
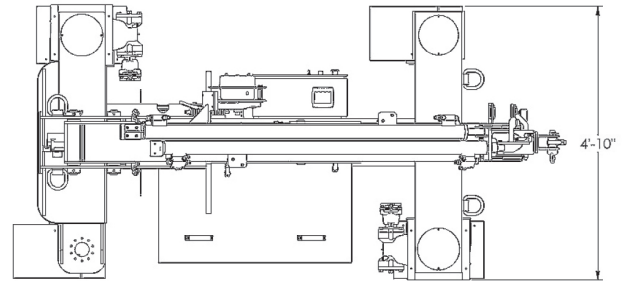
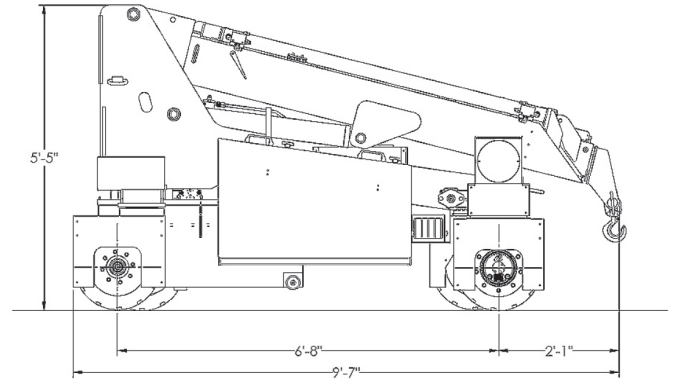

ENGINEERING THE FUTURE OF LIFT EQUIPMENT

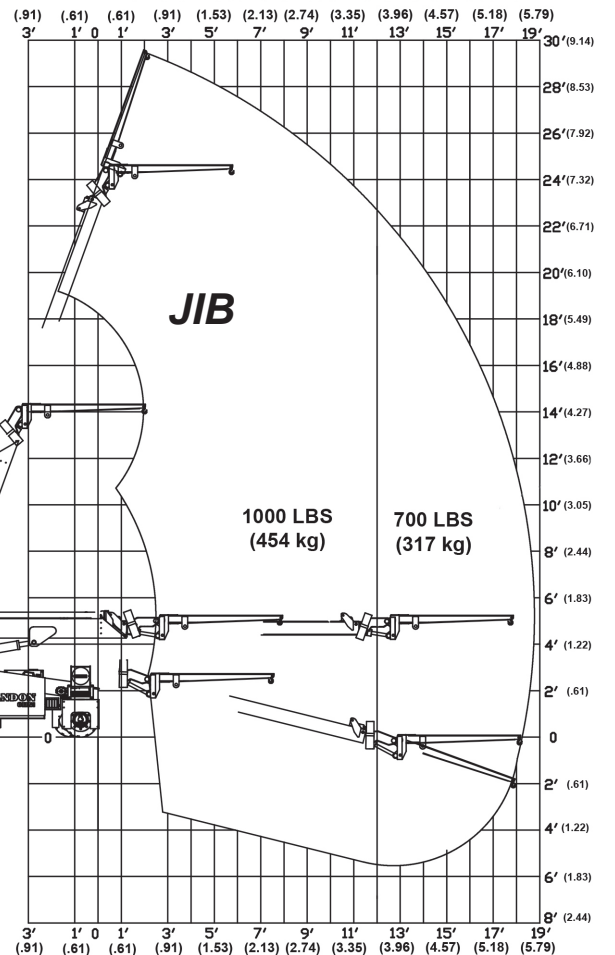
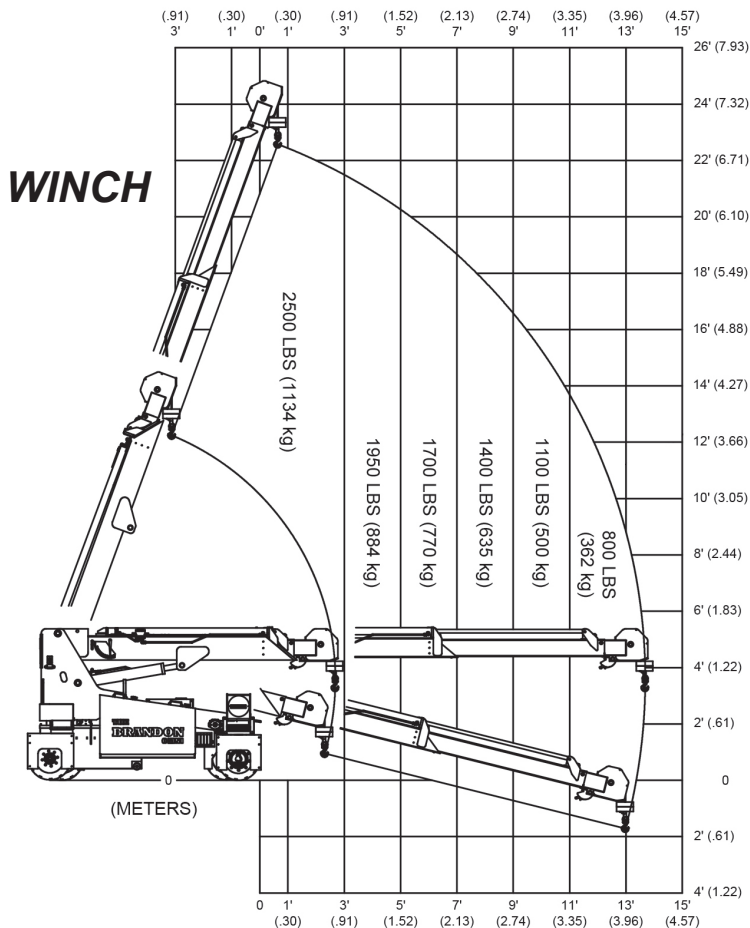
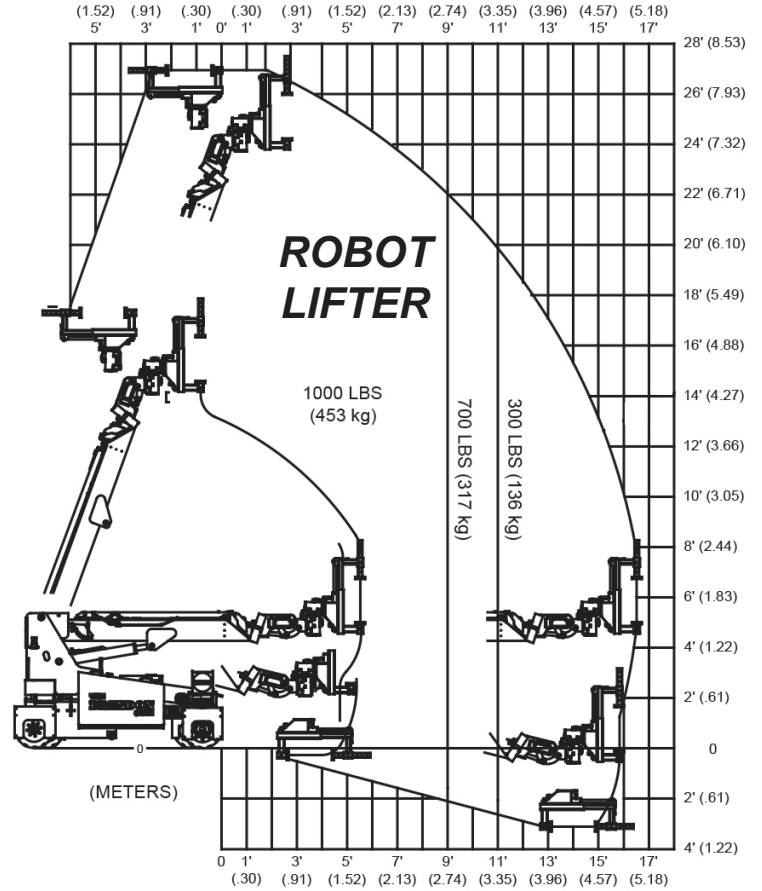
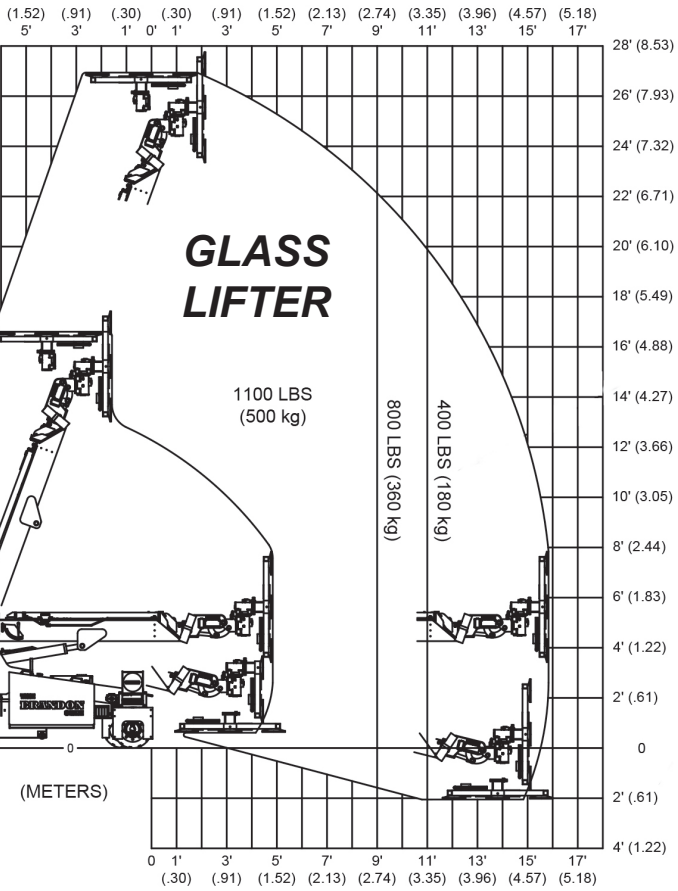

Features

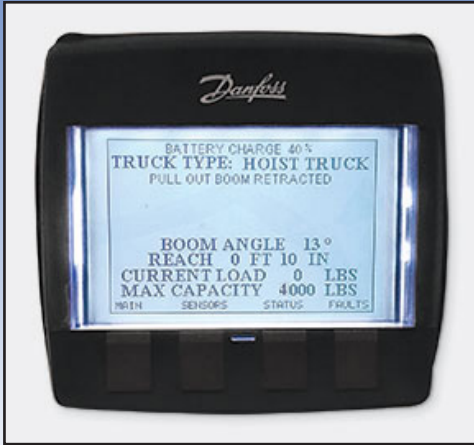

Rated Load Limiter

Automatically detects attachment and adjusts loading parameters

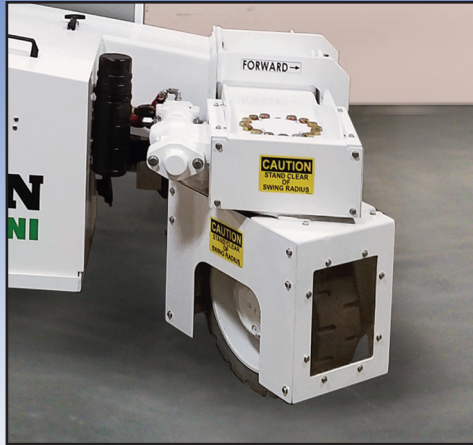

Wheel Covers

For safety and protection of the wheels



Removable Battery Box

For multi-shift operation.
Patented design loads without external sources.

Multiple Attachments

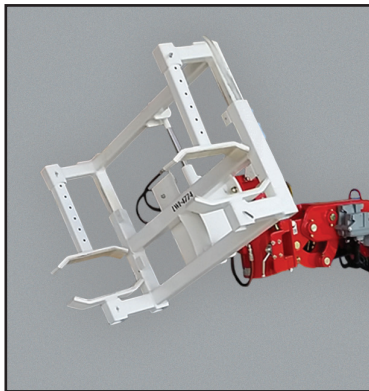

Robot



Man Basket



Winch



Forks



Glass



Hanging Glass

