



Rheem® Non-Thermostatic Tankless Electric Water Heater

Applications

- Handwashing
- Point-of-use & fixed-flow fixture
- One (1) lavatory faucet, sensor faucet or metering faucet*

Performance Features

- InfoCue™ visible LED indicator communicates system status and heater operation feedback
- SafeStart™ technology engages upon start-up to help avoid dry-fire occurrence
- Low flow activation at 0.25 GPM (model dependent)
- Mounts in any orientation for a flexible installation
- Compact size fits almost anywhere; suitable for ADA compliant facilities

- Only one cold water line needed for an easy installation
- No T&P relief valve needed (check local codes); Ready to go, right out-of-the-box
- Save water and time by installing unit at the point-of-use
- Integral 3/8" compression fittings; no soldering or sweat connections required
- Control system activates heater only on demand
- High temperature limit switch enables safe operation

Warranty

- 5-Year limited warranty on leaks, 1-year on parts

See Residential Warranty Certificate for complete information



Non-Thermostatic Tankless Electric

Note: For optimum performance, mounting location should be within 2 feet of fixture.

*Thermostatic or manual mixing valves are NOT to be used.



Tested and certified by the Water Quality Association against NSF/ANSI 372 for lead free compliance.



Suggested Specification

Tankless water heater shall be a Rheem model number RTEH_____.

Unit shall have ABS-UL 94-5VA rated cover. Unit shall allow mounting in any orientation. Element shall be replaceable cartridge insert. Element shall be iron-free, nickel-chrome material. Unit shall have replaceable filter in the inlet connector. Unit shall include an integrated flow meter to ensure accurate turn-on / turn-off flow rate. Heater shall be fitted with 3/8" compression fittings to eliminate the need for soldering. Maximum operating pressure of 150 PSI. Diagnostic features to include LED error/fault indicator. Heater shall employ technology that engages upon start-up to avoid dry-fire occurrence. Hot water storage tanks prohibited. Unit shall be Rheem or approved equal.

NOTE: Refer to rating chart for product information.

Product Specifications

Dimensions:	10.75" H x 5.25" W x 3" D
Product Weight: (model dependent)	2.75 lb/3 lb
Cover:	ABS-UL 94-5VA
Color:	Cool Grey
Minimum Operating Pressure:	30 PSI
Maximum Operating Pressure:	150 PSI
Element:	Replaceable nichrome cartridge insert
Fittings:	3/8" compression fittings
UL listed file number:	E86887

U.S. Patent Pending Technology



Rheem® Non-Thermostatic Tankless Electric Water Heater Specifications

DESCRIPTION	FEATURES				TEMPERATURE RISE °F						ENERGY INFO	
	MODEL NUMBER	kW	AMPS	RECOMMENDED WIRE SIZE (75° C/CU)	TURN ON (GPM)	0.3 GPM	0.5 GPM	0.75 GPM	1.0 GPM	1.5 GPM	2.0 GPM	UNIFORM ENERGY FACTOR (UEF)
VOLTS 120												
RTEH1812	1.8	15	14 AWG	0.2	41°	25°	16°	12°	8°	6°		0.96
RTEH2412	2.4	20	14 AWG	0.25	55°	33°	22°	16°	11°	8°		0.96
RTEH3012	3.0	25	12 AWG	0.25	68°	41°	27°	20°	14°	10°		0.96
RTEH3512	3.5	29	10 AWG	0.3	80°	48°	32°	24°	16°	12°		0.96
VOLTS 208 Single Phase												
RTEH3208	3.0	15	14 AWG	0.25	68°	41°	27°	20°	14°	10°		0.97
RTEH4208	4.1	20	14 AWG	0.4	–	56°	37°	28°	19°	14°		0.97
RTEH8208	8.3	40	8 AWG	0.7	–	–	76°	57°	38°	28°		0.96
VOLTS 240*												
RTEH35	3.5	15	14 AWG	0.3	80°	48°	32°	24°	16°	12°		0.95
RTEH35 (derated 208V performance)	2.6	13	14 AWG	0.3	59°	36°	24°	18°	12°	9°		0.95
RTEH48	4.8	20	14 AWG	0.4	–	66°	44°	33°	22°	16°		0.96
RTEH48 (derated 208V performance)	3.6	17	14 AWG	0.4	–	49°	33°	25°	16°	12°		0.96
RTEH55	5.5	23	12 AWG	0.5	–	75°	50°	38°	25°	19°		0.96
RTEH55 (derated 208V performance)	4.1	20	12 AWG	0.5	–	56°	37°	28°	19°	14°		0.96
RTEH65	6.5	27	10 AWG	0.7	–	–	59°	44°	30°	22°		0.96
RTEH65 (derated 208V performance)	4.8	23	10 AWG	0.7	–	–	44°	33°	22°	16°		0.96
RTEH75	7.5	32	10 AWG	0.7	–	–	68°	51°	34°	26°		0.96
RTEH75 (derated 208V performance)	5.6	27	10 AWG	0.7	–	–	51°	38°	25°	19°		0.96
RTEH95	9.5	40	8 AWG	0.8	–	–	–	65°	43°	32°		0.96
RTEH95 (derated 208V performance)	5.6	34	8 AWG	0.8	–	–	–	38°	25°	19°		0.96
VOLTS 277 Single Phase												
RTEH3277	3.0	11	14 AWG	0.25	68°	41°	27°	20°	14°	10°		0.96
RTEH4277	4.1	15	14 AWG	0.4	–	56°	37°	28°	19°	14°		0.96
RTEH60	6.0	22	12 AWG	0.7	–	–	55°	41°	27°	20°		0.96
RTEH80	8.0	29	10 AWG	0.7	–	–	73°	55°	36°	27°		0.96
RTEH90	9.0	33	10 AWG	0.7	–	–	82°	61°	41°	31°		0.96
RTEH100	10.0	36	8 AWG	0.8	–	–	–	68°	46°	34°		0.96

For Canadian model number, add CA to the end of the model number. Ex: RTEH1812CA. Canadian models comply to either Underwriters Laboratories (UL) or Intertek (ETL) under CAN/CSA-C22.2 No. 64/No. 88.

*240V units can be used on 208V single phase with 25% reduced temperature output. Please note per UL standards the rating plate and installation instructions will all be according to a 240V applied voltage. Check with local officials prior to derating the electrical infrastructure.

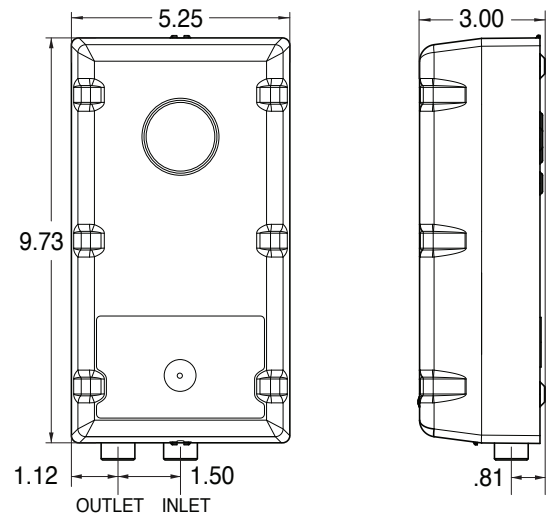

In keeping with its policy of continuous progress and product improvement, Rheem reserves the right to make changes without notice.

Rheem Water Heating • 1115 Northmeadow Parkway, Suite 100
Roswell, Georgia 30076 • www.rheem.com

Rheem Canada Ltd./Ltée • 125 Edgeware Road, Unit 1
Brampton, Ontario L6Y 0P5 • www.rheem.ca