



# FBZ™

## Electric Steam Boiler

90 – 1300 kW

- ▶ Zero Scope-1 Emissions
- ▶ High Steam Quality
- ▶ Intuitive Touchscreen Control



**ALL MODELS:**

315 - 4,550 lb/hr Output F&A 212°F  
ASME Section I and IV Designs



# DEFINING THE NEW STANDARD FOR ELECTRIC BOILERS

FBZ boilers are designed to meet sustainability demands with industry-leading features as standard. By eliminating the use of fossil fuels and combustion processes, these boilers provide a clean and green alternative for a variety of industrial and commercial applications.

## Standard Features

- ✓ Incolloy 800 sheathed elements
- ✓ 100kA SCCR Rating\*
- ✓ ASME Section I or IV
- ✓ cULus-834
- ✓ CSD-1
- ✓ SCR
- ✓ Modbus ready; BACnet capable

*\*With appropriate fused disconnects installed upstream of unit*



## INTUITIVE ADVANCED TOUCHSCREEN

- ▶ 5.7" Color Touchscreen
- ▶ Dedicated BMS Modbus
  - Other Integration Options Available
- ▶ Standard I/O
  - Dedicated Outputs for Element Staging
  - Individual Input Monitoring for Safety Devices with Alarm Annunciation



# RUGGED DESIGN, LONGER LIFE

The Fulton FBZ comes fully packaged and factory tested. The boiler features a rugged design with a fully-insulated pressure vessel for minimal jacket losses. A carefully calculated heat-to-water ratio achieves operating pressures quickly and with nearly 100% efficiency.

## A Advanced Controls

Touchscreen provides access to element staging data and full BMS integration.

## B High Quality Steam

Large water volume and tall steam space combine to provide high quality dry steam over a wide range of operating conditions.

## C Durable & Long Lasting

Thick-walled pressure vessel exceeds ASME minimum requirements.

## D Ease of Use & Maintenance

User friendly control interface and horizontal element bundles are easily accessible.



★ 10 YEAR ★

PRESSURE VESSEL  
WARRANTY



★ 2 YEAR ★

ELEMENT BUNDLE  
WARRANTY



★ 1 YEAR ★

PARTS  
WARRANTY



# SPECIFICATIONS & DIMENSIONS

	MODEL	FBZ-0090	FBZ-0150	FBZ-0210	FBZ-0270	FBZ-0400	FBZ-0500	FBZ-0600	FBZ-0700	FBZ-0800	FBZ-1000	FBZ-1300
<b>SPECIFICATIONS</b>												
Unit Size	kW	90	150	210	270	400	500	600	700	800	1,000	1,300
Steam Output	LBS/HR	315	525	735	945	1,400	1,750	2,100	2,450	2,800	3,500	4,550
Output	BTU/HR	307,080	511,800	716,520	921,240	1,364,800	1,706,000	2,047,200	2,388,400	2,729,600	3,412,000	4,435,600
Water Capacity	GAL	93	93	93	93	335	335	395	395	395	628	628
<b>ELECTRICAL (FLA)</b>												
208/60/3	AMPS	255	421	588	754	N/A	N/A	N/A	N/A	N/A	N/A	N/A
240/60/3	AMPS	220	364	508	653	N/A	N/A	N/A	N/A	N/A	N/A	N/A
480/60/3	AMPS	110	182	254	326	483	603	723	844	964	1,204	1,565
600/60/3	AMPS	88	146	203	261	386	482	579	675	771	964	1,252
<b>DIMENSIONS</b>												
(A) Height w/o Trim	IN	75 7/8	75 7/8	75 7/8	75 7/8	83 3/4	83 3/4	97 1/2	97 1/2	97 1/2	97 3/4	97 3/4
(B) Width	IN	56 3/4	56 3/4	56 3/4	56 3/4	76 5/8	76 5/8	74 1/2	74 1/2	74 1/2	91 3/4	91 3/4
(C) Depth	IN	43 3/4	43 3/4	43 3/4	43 3/4	65 3/4	65 3/4	65 5/8	65 5/8	65 5/8	84 1/2	84 1/2
(D) Element Pull Clearance	IN	36	36	36	36	47	47	46	46	46	42 3/8	42 3/8
<b>WEIGHTS</b>												
Shipping Weight	LBS	1,500	1,500	1,500	1,500	4,300	4,300	4,500	4,500	4,500	8,580	8,580
Operating Weight	LBS	2,125	2,125	2,125	2,125	6,800	6,800	7,640	7,640	7,640	13,500	13,500

*NOTE: Specifications and dimensions are approximate and for reference only. Fulton practices continuous product improvement and reserves the right to change specifications and/or dimensions without notice.*

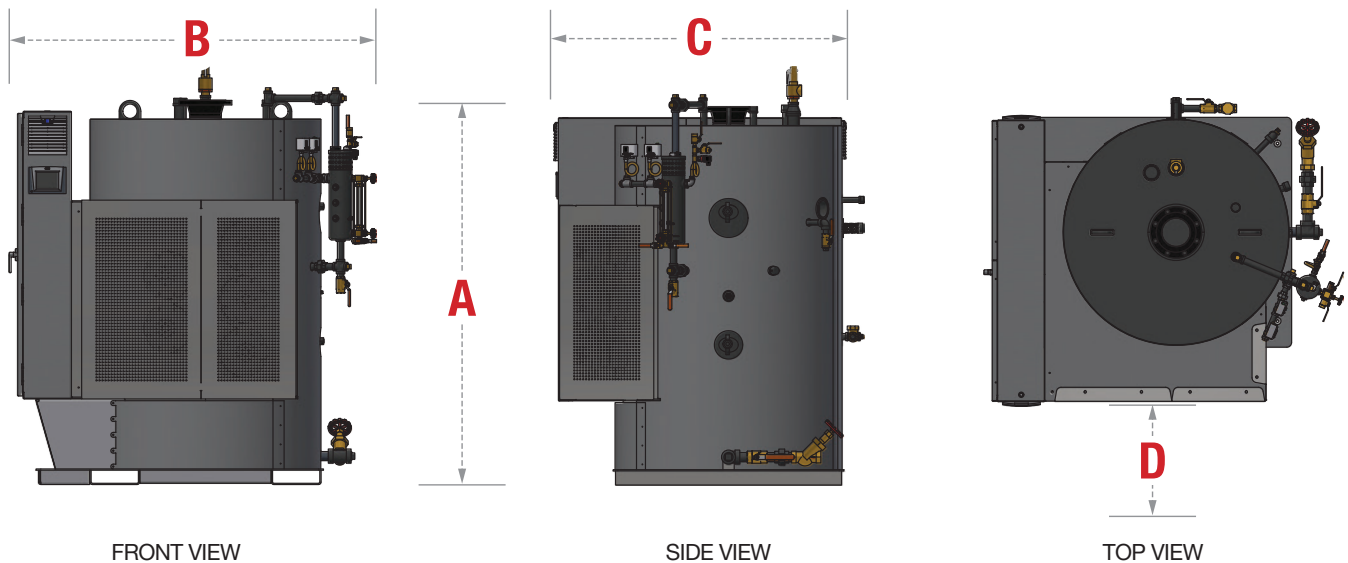

Call: (315) 298-5121

972 Centerville Road  
Pulaski, NY 13142



[fulton.com/fbz](http://fulton.com/fbz)

Drawings & documentation available online

FBZ-90-1300\_BROCHURE\_241207

