

MODEL VD

Weld Neck Flanges - DIN 2633 (PN16) or DIN 2635 (PN40)

DESCRIPTION AND GENERAL PERFORMANCE SPECIFICATIONS

The V-Cone® flowmeter is a patented, differential pressure type flow measurement device. A cone is positioned in the center of the pipe to increase the velocity of the flowing fluid and create a differential pressure. This pressure difference can be measured and used to accurately interpret flowrate. Two taps are provided on every V-Cone to allow sensing of the high and low pressures. A typical V-Cone application can follow these general performance specifications:

- Accuracy: up to $\pm 0.5\%$ of rate
- Repeatability: $\pm 0.1\%$
- Turndown: 10:1
- Standard Betas: 0.45 through 0.85
- Headloss: Percentage of differential pressure produced varies with beta ratio.
- Installation: Typically 0-3 diameters upstream and 0-1 diameters downstream.



The V-Cone is manufactured under a quality management system that is certified to ISO 9001:2015.

* Each V-Cone is sized for the intended application. Specific performance ratings must be obtained through the sizing process.

MODEL VD DIMENSIONS

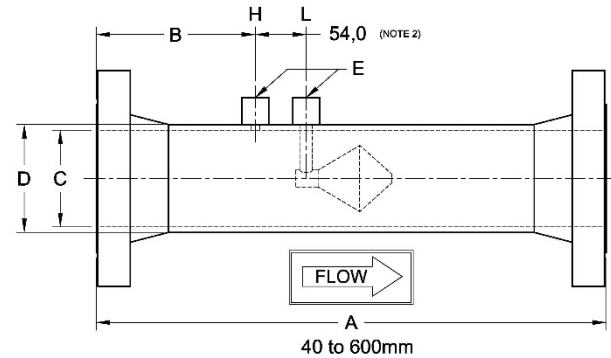
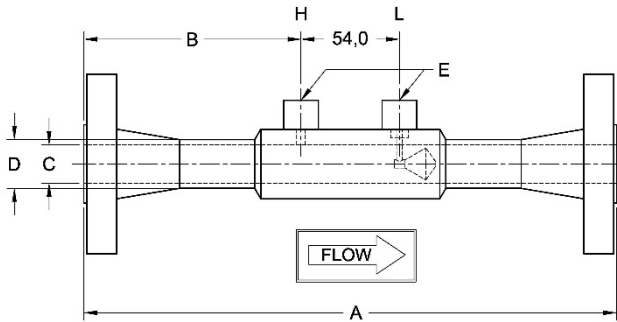

DIMENSION TABLE

Size		DIN 2633 (PN16)		DIN 2635 (PN40)		Stainless	Carbon	D	E (Note 2)
		A (Note 1)	B	A (Note 1)	B	C (Note 2)	C (Note 2)		
DN	inch	mm	mm	mm	mm	mm	mm	mm	NPT
15	½	263,7	104,9	269,7	107,9	15,8	-	21,3	¼
20	¾	269,7	107,9	273,6	109,9	20,9	-	26,7	¼
25	1	269,7	107,9	273,6	109,9	26,6	-	33,4	¼
40	1½	325,4	112,0	331,2	115,1	41,8	-	48,3	¼
50	2	379,0	126,0	385,1	128,8	53,4	-	60,3	½
65	2½	375,7	124,5	389,6	131,3	63,6	-	73,0	½
80	3	436,6	129,3	452,6	137,4	78,8	-	88,9	½
100	4	491,2	144,0	517,4	157,0	103,9	-	114,3	½
150	6	649,7	153,4	689,9	173,5	154,1	154,1	168,3	½
200	8	759,0	176,5	811,0	202,4	202,7	202,7	219,1	½
250	10	825,8	184,4	895,9	219,5	254,5	254,5	273,1	½
300	12	892,6	198,9	966,7	235,7	304,8	303,2	323,9	½
350	14	894,3	218,4	980,2	261,6	336,6	333,4	355,6	½
400	16	900,2	221,5	1000,3	271,5	387,4	381,0	406,4	½
500	20	1062,7	226,6	1162,6	276,6	489,0	489,0	508,0	½
600	24	1377,4	333,2			590,6	590,6	609,6	½

1. Overall length (A) tolerance varies with line size: 15 to 25mm, $\pm 2\text{mm}$; 40 to 250mm, $\pm 4\text{mm}$; 300 to 600mm, $\pm 6\text{mm}$.
2. Typical values shown.
3. Wall pressure ports are required for vertical up flow applications.



SPECIFICATION SHEET

MODEL NUMBER CONFIGURATION VD

Type	Size		Materials‡		Pipe Schedule		End Connections		Fittings	
VD										
	0A	15	Q	S304/L	D	Std	24	DIN 2633 RF WN	N	NPT
	0B	20	A	S316/L	R	30	25	DIN 2635 RF WN	S	Socket
	01	25	U	CS Pipe S304 Cone, Support, & Couplings	E	40			F	Direct mount assembly
	0C	40			Q	60				
	02	50	F	CS Pipe, Flanges, & Couplings, 316/L Cone & Supports	F	80				
	0D	65			J	100				
	03	80	V	CS Pipe 316/L Cone, Supports, & Couplings	K	120				
	04	100			L	140				
	06	150	G	LTCS Pipe, Flanges, & Couplings, S316/L Cone & Supports	G	160				
	08	200			P	XS				
	10	250			H	XXS				
	12	300								
	14	350								
	16	400								
	20	500								
	24	600								

Several types of fittings available.

‡Other materials can include:
 HASTELLOY C-276
 DUPLEX 2205
 CHROMEMOLY P22/P11
 MONEL K400/K500
 CARBON STEELS
 A350, A333, API5L, A106B
 S321H
 INCONEL 625

Example: VD06QE24N is a V-Cone 150mm line size, S304, schedule 40 pipe, DIN 2633 RF WN flanges, and ½" NPT fittings.

STANDARD PIPE SCHEDULES

Stainless Steel		Carbon Steel	
Size (mm)	Std.	Size (mm)	Std.
15 to 250	E	150 to 400	E
300 and up	D	500 and up	D

Meters 6" and smaller utilize seamless pipe.
 Meters 8" and larger utilize welded pipe.

ABBREVIATIONS

ASME	American Society of Mechanical Engineers		
NPT	National pipe taper		
SS	Stainless steel	RF	Raised Face
CS	Carbon steel	WN	Weld Neck

Technical questions can be answered through a local representative or through our application engineers.

MANUFACTURING STANDARDS

McCrometer's welders and welding procedures are qualified in accordance with ASME Section IX. All meters are visually inspected for weld defects. Specific customer requirements can be complied with upon request.

The welding can be in accordance with:

- ASME Section VIII
- ASME B31.1
- ASME B31.3

Non-destructive testing can include:

- Hydrostatic Pressure Testing
- Penetrant Examination
- Radiographic Examination
- Positive Material Inspection
- Magnetic Particle Examination

REPRESENTED BY:

