



Rheem® Thermostatic Tankless Electric Water Heater with Integrated Mixing Valve

Applications

- Handwashing
- Lavatory sinks
- Ideal for sensor or metering faucets

Performance Features

- Integrated mixing valve meets ASSE 1070
- Unit meets UPC 407.3 requirements when properly installed
- Self-diagnostics with intelligent controls actively protect heater in installed environment
- SafeStart™ technology engages upon start-up to help avoid dry-fire occurrence
- Low flow activation at 0.3 GPM
- Digital LED display communicates system status and heater operation feedback
- Silent operation on all models except for RTEH012240MV
- Mounts in any orientation for a flexible installation
- Compact size fits almost anywhere; suitable for ADA compliant facilities

- Only one input line, hot or cold, needed for an easy installation*
- Designed to deliver hot water to a single pipe faucet or mixing faucets
- Integral 3/8" compression fittings; no soldering or sweat connections required
- No T&P relief valve needed (check local codes); Ready to go, right out-of-the-box
- Save water and time by installing unit at the point-of-use
- Control system activates heater only on demand
- High temperature limit switch enables safe operation
- Active energy management with power modulation allows for thermostatic accuracy

Warranty

- 5-Year limited warranty on leaks, 1-year on parts

See Residential Warranty Certificate for complete information



Thermostatic Tankless Electric with Integrated Mixing Valve



Water Heater in accordance with NSF/ANSI 372 MH49688



Note: For optimum performance, mounting location should be within 2 feet of fixture.

*Inlet water temperature cannot exceed 100°F.

Suggested Specification

Tankless water heater shall be a Rheem model number RTEH_____MV.

Unit shall have ABS-UL 94-5VA rated cover. Unit shall have 0.3 GPM turn on. Unit shall allow mounting in any direction. Uses ASSE 1070 approved integrated mixing valve to conform to UPC 407.3. Element shall be replaceable cartridge insert. Unit shall have replaceable filter in the inlet connector. Element shall be iron free, Nickel Chrome material. Tankless water heater to utilize complex algorithm, actively managing power application to real time system demand. Integrated flow meter, along with inlet and outlet temperature sensors provide data which allows the unit to instantly adapt to variations in input parameters. Heater shall be fitted with 3/8" compression fittings to eliminate need for soldering. Maximum operating pressure of 150 PSI. Diagnostic features to include error/fault display. Hot water storage tanks prohibited. Unit shall be Rheem or approved equal.

Product Specifications

Dimensions:	14.50" H x 5.25" W x 4" D
Weight:	5.5 lb
Cover:	ABS-UL 94-5VA
Color:	Cool Grey
Temperature:	Factory set to 105°F
Min. Dynamic Operating Pressure:	35 PSI
Max. Dynamic Operating Pressure:	150 PSI
Element:	Replaceable nichrome cartridge insert
Fittings:	3/8" compression fittings
UL listed file number:	E86887

U.S. Patent Pending Technology



Rheem® Thermostatic Tankless Electric Water Heater with Integrated Mixing Valve Specifications

DESCRIPTION	FEATURES					TEMPERATURE RISE °F				ENERGY INFO
	MODEL NUMBER	kW	AMPS	RECOMMENDED WIRE SIZE (75° C/CU)	# OF 0.5 AERATORS SUPPLIED/UNIT	TURN ON (GPM)	0.3 GPM	0.5 GPM	1.0 GPM	1.5 GPM
VOLTS 120										
RTEH004120MV**	3.5	29	10 AWG	1	0.3	80°	48°	24°	16°	0.94
VOLTS 240*										
RTEH005240MV**	4.8	20	14 AWG	1	0.3	†	66°	33°	22°	0.96
RTEH005240MV (derated 208V perf.)	3.6	17	14 AWG	1	0.3	†	49°	25°	16°	0.96
RTEH007240MV**	6.5	27	10 AWG	2	0.3	†	†	44°	30°	0.95
RTEH007240MV (derated 208V perf.)	5.0	24	10 AWG	2	0.3	†	68°	34°	23°	0.95
RTEH010240MV**	9.5	40	8 AWG	3	0.3	†	†	65°	43°	0.96
RTEH010240MV (derated 208V perf.)	7.5	36	8 AWG	3	0.3	†	†	51°	34°	0.96
RTEH012240MV**	11.5	48	8 AWG	4	0.3	†	†	79°	52°	0.95
RTEH012240MV (derated 208V perf.)	8.7	42	8 AWG	4	0.3	†	†	59°	40°	0.95
VOLTS 277										
RTEH004277MV	4.1	15	14 AWG	1	0.3	†	56°	28°	19°	0.94
RTEH008277MV	8.0	29	10 AWG	2	0.3	†	†	55°	36°	0.96
RTEH010277MV	10.0	36	8 AWG	3	0.3	†	†	68°	46°	0.96

* 240V units can be used on 208V single phase with 25% reduced temperature output. Please note per UL standards the rating plate and installation instructions will all be according to a 208V to 240V single phase applied voltage. Check with local officials prior to derating the electrical infrastructure.

** indicates evaluation and compliance to either Underwriters Laboratories (UL) or Intertek (ETL) under CAN/CSA-C22.2 No. 64/No. 88.

† Units are factory preset to 105°F.

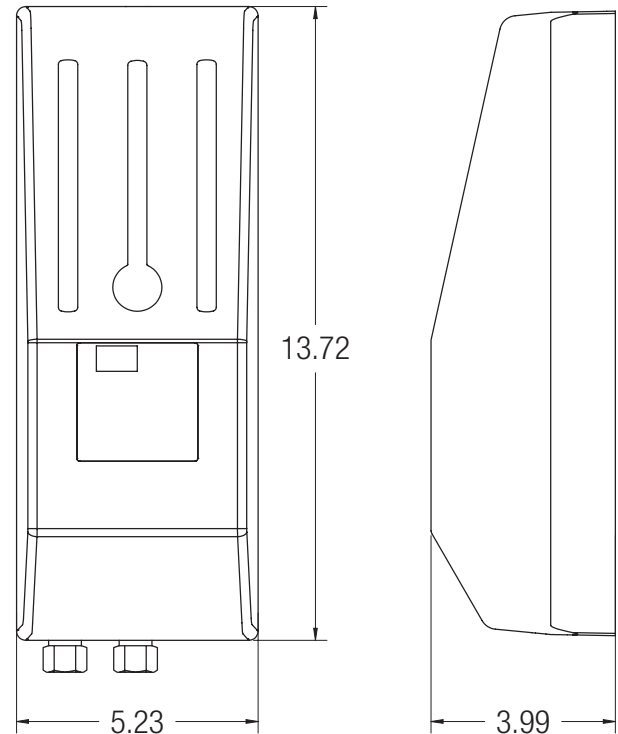

In keeping with its policy of continuous progress and product improvement, Rheem reserves the right to make changes without notice.

Rheem Water Heating • 1115 Northmeadow Parkway, Suite 100
Roswell, Georgia 30076 • www.rheem.com

Rheem Canada Ltd./Ltée • 125 Edgeware Road, Unit 1
Brampton, Ontario L6Y 0P5 • www.rheem.ca